

AHRI Standard 1320-2011 (I-P)

**2011 Standard for
Performance Rating of
Commercial Refrigerated
Display Merchandisers and
Storage Cabinets for Use With
Secondary Refrigerants**



we make life better®

2311 Wilson Boulevard, Suite 400
Arlington, VA 22201, USA
www.ahrinet.org
PH 703.524.8800
FX 703.562.1942

IMPORTANT

SAFETY DISCLAIMER

AHRI does not set safety standards and does not certify or guarantee the safety of any products, components or systems designed, tested, rated, installed or operated in accordance with this standard/guideline. It is strongly recommended that products be designed, constructed, assembled, installed and operated in accordance with nationally recognized safety standards and code requirements appropriate for products covered by this standard/guideline.

AHRI uses its best efforts to develop standards/guidelines employing state-of-the-art and accepted industry practices. AHRI does not certify or guarantee that any tests conducted under its standards/guidelines will be non-hazardous or free from risk.

Note:

This is a new standard.

For SI ratings, see AHRI Standard 1321-2011 (SI).

Approved as an American National Standard (ANS) on 17 April 2012.

ANS expired 17 April 2022.

TABLE OF CONTENTS

SECTION		PAGE
Section 1.	Purpose	1
Section 2.	Scope	1
Section 3.	Definitions	1
Section 4.	Test Requirements	3
Section 5.	Rating Requirements	3
Section 6.	Symbols and Subscripts.....	8
Section 7.	Minimum Data Requirements for Published Ratings.....	9
Section 8.	Marking and Nameplate Data.....	9
Section 9.	Conformance Conditions.....	9

TABLES

Table 1.	EER for Remote Commercial Refrigerated Display Merchandisers and Storage Cabinets for Use With Secondary Refrigerants	6
Table 2.	Presentation of Data for Remote Commercial Refrigerated Display Merchandisers and Storage Cabinets for Use With Secondary Refrigerants	10

APPENDICES

Appendix A.	References - Normative	11
Appendix B.	References - Informative.....	11
Appendix C.	Commercial Refrigerated Display Merchandisers and Storage Cabinets for Use with Secondary Refrigerants Load Line Volume Calculation - Normative.....	12
Appendix D.	Commercial Refrigerated Display Merchandisers for Use with Secondary Refrigerants Total Display Area (TDA) Calculation - Normative	15
Appendix E.	Example – Energy Performance Representation for Remote Commercial Refrigerated Display Merchandisers or Storage Cabinets for Use with Secondary Refrigerants - Informative.....	20

TABLES FOR APPENDICES

Table E1.	Sample Presentation of Data for Remote Commercial Refrigerated Display Merchandisers and Storage Cabinets for Use with Secondary Refrigerants	22
-----------	---	----

FIGURES FOR APPENDICES

Figure C1.1.	Sample Isometric View of Commercial Refrigerated Display Merchandisers for Illustrating Length of Refrigerated Space.....	12
Figure C1.2.	Sample Cross Sections of Commercial Refrigerated Display Merchandisers for Load Line Volume Calculation.....	13
Figure C2.	Sample Cross Section of Commercial Refrigerated Storage Cabinets for Volume Calculation.....	14
Figure D1.	Vertical Open Multi-deck.....	15
Figure D2.	Vertical Open Multi-deck with Transparent Front.....	15
Figure D3.	Semi-vertical Open Multi-deck	16
Figure D4.	Semi-vertical Open Multi-deck with Transparent Front	16
Figure D5.	Horizontal Open Single-deck	16

Figure D6.	Horizontal Open Single-deck with Transparent Front	16
Figure D7.	Service Over Counter with Flat Transparent Front	17
Figure D8.	Service Over Counter with Curved Transparent Front.....	17
Figure D9.	Horizontal Open Single-deck Island	17
Figure D10.	Horizontal Open Single-deck Island with Transparent Wall	17
Figure D11.	Horizontal Open Single-deck Island with Transparent Walls	17
Figure D12.	Vertical Closed Multi-deck with Transparent Doors	17
Figure D13.	Vertical End Wall with Transparent Section.....	18
Figure D14.	Semi-vertical End Wall with Transparent Section	18
Figure D15.	Horizontal Single-deck and Single-deck Island End Wall with Transparent Section.....	18
Figure D16.	Service Over Counter End Wall with Transparent Section.....	18
Figure D17.	Example TDA for Unique Geometries.....	19

PERFORMANCE RATING OF COMMERCIAL REFRIGERATED DISPLAY MERCHANDISERS AND STORAGE CABINETS FOR USE WITH SECONDARY REFRIGERANTS

Section 1. Purpose

1.1 Purpose. The purpose of this standard is to establish for Commercial Refrigerated Display Merchandisers and Storage Cabinets that use secondary refrigerants: definitions; test requirements; rating requirements; symbols and subscripts; minimum data requirements for Published Ratings; marking and nameplate data and conformance conditions.

1.1.1 Intent. This standard is intended for the guidance of the industry, including manufacturers, engineers, installers, contractors and users. The values reported using this standard allow comparison of energy consumption within each of the following product categories: Remote Commercial Refrigerated Display Merchandisers, Remote Commercial Refrigerated Storage Cabinets and Self-contained Commercial Refrigerated Display Merchandisers.

1.1.2 Review and Amendment. This standard is subject to review and amendment as technology advances.

Section 2. Scope

2.1 Scope. This standard applies to the following Commercial Refrigerated Display Merchandisers and Storage Cabinets, provided that the cases are equipped and designed to work with electrically driven, medium-temperature, single-phase secondary coolant systems:

2.1.1 Remote Commercial Refrigerated Display Merchandisers and Storage Cabinets

2.1.2 Open and Closed Commercial Refrigerated Display Merchandisers

2.2 Exclusions. This standard does not apply to the following:

2.2.1 Refrigerated vending machines

2.2.2 Ice makers

2.2.3 Soft serve extruders

2.2.4 Low-temperature applications

2.2.5 Secondary coolants involving a change of phase (e.g. ice slurries, CO₂)

2.2.6 Self-contained Commercial Refrigerated Display Merchandisers and storage cabinets

Section 3. Definitions

All terms in this document shall follow the standard industry definitions in the current edition of *ASHRAE Terminology of Heating, Ventilation, Air Conditioning and Refrigeration* unless otherwise defined in this section.

3.1 Anti-condensate Energy Consumption (AEC). The Total Daily Energy Consumption used in condensate removal on the outside of the Commercial Refrigerated Display Merchandiser or Storage Cabinet, which typically includes fan and condensate heater energy expressed in kW·h per day.

3.2 Calculated Daily Energy Consumption (CDEC). This is a value for Remote Commercial Refrigerated Display Merchandisers or Storage Cabinets based upon the requirements of this standard expressed in kW·h per day.

3.3 Circulation Pump Energy Consumption (CPEC). The energy consumed by the pump used to circulate secondary coolant expressed in kW·h per day.

- 3.4** *Circulation Pump Heat Input (Q_{CP})* The energy transferred to the secondary coolant as a result of the work done on the coolant by the circulation pump expressed in Btu/h.
- 3.5** *Commercial Refrigerated Display Merchandiser.* A cabinet cooled by a refrigerating system for displaying chilled and/or frozen food to be maintained within prescribed temperature limits.
- 3.5.1** *Closed Commercial Refrigerated Display Merchandiser.* A refrigerated display merchandiser where food is accessible for removal by opening or moving doors or panels.
- 3.5.2** *Open Commercial Refrigerated Display Merchandiser.* A refrigerated display merchandiser where food is accessible for removal without opening or moving doors or panels.
- 3.5.3** *Remote Commercial Refrigerated Display Merchandiser.* A refrigerated display merchandiser that has a remote condensing unit.
- 3.5.4** *Service Over the Counter (SOC).* A commercial refrigerator or freezer equipped with sliding or hinged doors in the back intended for use by sales personnel, and with glass or other transparent material in the front for displaying merchandise. The equipment has a height no greater than 66 inches and is intended to serve as a counter for transactions between sales personnel and customers.
- 3.6** *Commercial Refrigerated Storage Cabinet.* A closed cabinet cooled by a refrigerating system for storing chilled and/or frozen food to be maintained within prescribed temperature limits.
- 3.6.1** *Remote Commercial Refrigerated Storage Cabinet.* A refrigerated storage cabinet that has a remote condensing unit.
- 3.7** *Compressor Energy Consumption (CEC).* The energy consumed by the compressor expressed in kW·h per day.
- 3.8** *Condensate Evaporator Pan Energy Consumption (PEC).* The amount of heat energy required to change condensate from liquid to a vapor in the evaporator pan expressed in kW·h per day.
- 3.9** *Defrost Energy Consumption (DEC).* The energy consumed during defrost cycles expressed in kW·h per day.
- 3.10** *Dew Point.* Refrigerant vapor saturation temperature at a specified pressure expressed in °F.
- 3.10.1** *Adjusted Dew Point.* An adjusted temperature lower than actual Dew Point temperature expressed in °F, resulting from suction line pressure losses, equal to saturated suction temperature at the compressor.
- 3.11** *Energy Efficiency Ratio (EER).* A ratio of the cooling capacity in Btu/h to the power input values in watts at any given set of Rating Conditions expressed in Btu/(W·h).
- 3.12** *Fan Energy Consumption (FEC).* The energy consumed by fan motors expressed in kW·h per day.
- 3.13** *Integrated Average Temperature.* The average of all test package measurements taken during the test expressed in °F.
- 3.14** *Lighting Energy Consumption (LEC).* The energy consumed by lighted shelves and lighting internal to the refrigerated display merchandiser or storage cabinet expressed in kW·h per day.
- 3.15** *Product Temperature.* Commercial Refrigerated Display Merchandisers or Storage Cabinets shall be tested with one or more of the following Integrated Average Temperatures:
- 3.15.1** *Medium Temperature Applications.* Commercial Refrigerated Display Merchandisers and Storage Cabinets intended for Medium Temperature Applications, shall have an Integrated Average Temperature of $3.3^{\circ}\text{C} \pm 1.1^{\circ}\text{C}$.
- 3.15.2** *Application Product Temperature.* This test allows Integrated Average Temperatures other than Section 3.15.1.

3.16 Published Rating. A statement of the assigned values of those performance characteristics, under stated Rating Conditions, by which a unit may be chosen for its application. The term Published Rating includes the rating of all performance characteristics shown on the unit or published in specifications, advertising or other literature controlled by the manufacturer, at stated Rating Conditions.

3.16.1 Application Rating. A rating based on tests performed at application Rating Conditions (other than Standard Rating Conditions).

3.16.2 Standard Rating. A rating based on tests performed at Standard Rating Conditions.

3.17 Rating Conditions. Any set of operating conditions under which a single level of performance results and which causes only that level of performance to occur.

3.17.1 Standard Rating Conditions. Rating Conditions used as the basis of comparison for performance characteristics.

3.18 Secondary Coolant. Fluid used for the transmission of heat without a complete or partial change of phase within the cabinet. This standard applies to single-phase applications where the fluid is 35% propylene glycol or a fluid with similar viscosity and heat transfer properties.

3.19 "Shall" or "Should". "Shall" or "should" shall be interpreted as follows:

3.19.1 Shall. Where "shall" or "shall not" is used for a provision specified, that provision is mandatory if compliance with the standard is claimed.

3.19.2 Should. "Should" is used to indicate provisions which are not mandatory but which are desirable as good practice.

3.20 Total Display Area (TDA). The sum of the projected area(s) for visible product expressed in ft².

3.21 Volume. Two methods are defined for determining refrigerated volume.

3.21.1 AHAM Volume Method. The interior volume of a refrigerator as calculated by AHAM HRF-1.

3.21.2 Load Line Volume Method. The gross interior volume of the refrigerator contained within the load limit lines. This gross volume shall be calculated without display devices installed.

Section 4. Test Requirements

4.1 Test Requirements. The tests required for this standard shall be conducted in accordance with ANSI/ASHRAE Standard 72.

4.1.1 Dry-Bulb Temperature. The average test-room dry-bulb temperature shall be 75.2°F ± 1.8°F, when measured in accordance with ANSI/ASHRAE Standard 72.

4.1.2 Wet-Bulb Temperature. The average test-room wet-bulb temperature shall be 64.4°F ± 1.8°F, when measured in accordance with ANSI/ASHRAE Standard 72.

Section 5. Rating Requirements

5.1 General. This section identifies the necessary data required to calculate the CDEC for Remote Commercial Refrigerated Display Merchandisers and Storage Cabinets for use with secondary refrigerants.

5.2 CDEC for Remote Commercial Refrigerated Display Merchandisers and Storage Cabinets. The total electrical load shall be measured and adjusted to determine CDEC. The electrical load categories shall include compressors, evaporator fan motors, lighting, surface anti-condensate load including fans and heaters, defrost heaters, condensate evaporator pans, secondary coolant circulation pumps and any other suitable electrical loads when they are part of the unit. If measured electrical loads are not available, the following calculations shall be done to determine the CDEC.

$$CDEC = CEC + FEC + LEC + AEC + DEC + PEC + CPEC \tag{1}$$

Remote Commercial Refrigerated Display Merchandisers and Storage Cabinets shall report the individual loads in the calculation of CDEC. Shown below are formulae for the required individual loads.

5.2.1 Calculation of CEC. The EER values in Table 1 shall be used to calculate CEC for a 24 hour period.

Note: The EER values in Table 1 are based on an evaporator temperature and the Commercial Refrigerated Display Merchandiser or Storage Cabinet classification. Commercial Refrigerated Display Merchandisers and Storage Cabinets for Medium Temperature Secondary Applications shall use a temperature that is 6.0°F lower than the Commercial Refrigerated Display Merchandiser or Storage Cabinet secondary coolant cabinet inlet temperature.

$$CEC = [(Q_{rt} + Q_{cp}) \cdot (t - t_{dt})] / (EER \cdot 1000) \tag{2}$$

5.2.2 Calculation of FEC. The FEC shall be measured data for all fan motors or calculated data using the motor efficiency:

$$FEC = (P_f \cdot t_f) / (1000) \tag{3}$$

Where:

$$P_f = (P_{fi} \cdot n) \quad \text{(measured)}$$

$$P_f = (P_{fo} \cdot n) / (\eta_m) \quad \text{(calculated)}$$

5.2.3 Calculation of LEC.

$$LEC = (P_{li} \cdot t_l) / (1000) \tag{4}$$

5.2.4 Calculation of AEC.

$$AEC = (P_{ai} \cdot t_a) / (1000) \tag{5}$$

5.2.5 Calculation of DEC.

$$DEC = (P_d \cdot t_d) / (1000) \tag{6}$$

5.2.6 Calculation of PEC.

$$PEC = (P_c \cdot t_c) / (1000) \tag{7}$$

5.2.7 Calculation of CPEC.

5.2.7.1 Off-Cycle Defrost.

For cabinets with secondary coolant pressure drop values equal to or less than 6.5 PSI, use the formula

$$CPEC = M \cdot K_1 \cdot (t - t_{dt}) / 1000 \tag{8}$$

Where:

$$K_1 = 9.4 \text{ Watts per GPM}$$

For cabinets with secondary coolant pressure drop values greater than 6.5 PSI, use the formula

$$CPEC = (M \cdot K_1 + M \cdot (PD - 6.5) \cdot K_2) \cdot (t - t_{dt})/1000 \quad 9$$

Where:

$$K_2 = 0.65 \text{ watts per PSI per GPM}$$

5.2.7.2 *Warm Fluid Defrost.*

For cabinets with secondary coolant pressure drop values equal to or less than 6.5 PSI, use the formula

$$CPEC = M \cdot K_1 \cdot (t)/1000 \quad 10$$

For cabinets with secondary coolant pressure drop values greater than 6.5 PSI, use the formula

$$CPEC = (M \cdot K_1 + M \cdot (PD - 6.5) \cdot K_2) \cdot (t)/1000 \quad 11$$

5.2.8 *Calculation of Q_{CP}.*

5.2.8.1 *Off-Cycle Defrost.*

$$Q_{CP} = CPEC \cdot K_3 \cdot K_4/(t-t_{dt}) \quad 12$$

Where:

$$K_3 = \text{pump efficiency} = 0.9 \text{ and}$$

$$K_4 = 3412 \text{ BTU per kW-h}$$

5.2.8.2 *Warm Fluid Defrost.*

$$Q_{CP} = CPEC \cdot K_3 \cdot K_4/(t) \quad 13$$

5.2.9 *Other Electric Energy Consumption.* If there are additional options that decrease or increase the electrical usage, they shall be noted under “Other Loads” (Section 7) with an appropriate calculation for energy consumption expressed in kW·h per day.

5.3 *Alternate Components - Direct Effects.* The energy consumption of substituted or alternate components shall be measured or calculated from the component’s nameplate rating. The energy usage of the substituted or alternate components shall be used to recalculate the CDEC in Section 5.2. The energy consumption of the substituted or alternate components and the recalculated CDEC shall be reported as shown in Section 7.

5.3.1 *FEC.* When removing or substituting a fan motor, the fan energy shall be measured or calculated according to Section 5.2.2. The energy usage of the substituted or alternate components shall be used to recalculate the CDEC according to Section 5.2. The energy consumption of the substituted or alternate components and the recalculated CDEC shall be reported according to Section 7. When calculating the fan motor energy for substituting a fan motor, the airflow rate produced from the assembly shall be equal to the original configuration.

5.3.2 *LEC.* When removing or substituting lighting, the lighting energy shall be measured or calculated according to Section 5.2.3. The energy usage of the substituted or alternate components shall be used to recalculate the CDEC

according to Section 5.2. The energy consumption of the substituted or alternate components and the recalculated CDEC shall be reported according to Section 7.

5.3.3 AEC. When removing or substituting an anti-condensate heater, the heater energy shall be measured or calculated according to Section 5.2.4. The energy usage of the substituted or alternate components shall be used to recalculate the CDEC according to Section 5.2. The energy consumption of the substituted or alternate components and the recalculated CDEC shall be reported according to Section 7.

5.3.4 DEC. When removing or substituting a defrost heater, the heater energy shall be measured or calculated according to Section 5.2.5. The energy usage of the substituted or alternate components shall be used to recalculate the CDEC according to Section 5.2. The energy consumption of the substituted or alternate components and the recalculated CDEC shall be reported according to Section 7.

5.3.5 PEC. When removing or substituting a condensate evaporator pan, the pan energy shall be measured or calculated according to Section 5.2.6. The energy usage of the substituted or alternate components shall be used to recalculate the CDEC according to Section 5.2. The energy consumption of the substituted or alternate components and the recalculated CDEC shall be reported according to Section 7.

Table 1. EER for Remote Commercial Refrigerated Display Merchandisers and Storage Cabinets for Use with Secondary Refrigerants	
Medium Temperature	
Adjusted Dew Point	EER^{1,2}
°F	
0.0	9.76
1.0	9.88
2.0	10.02
3.0	10.16
4.0	10.30
5.0	10.41
6.0	10.58
7.0	10.75
8.0	10.93
9.0	11.10
10.0	11.28
11.0	11.47
12.0	11.66
13.0	11.83
14.0	12.02
15.0	12.21
16.0	12.44
17.0	12.65
18.0	12.86
19.0	13.07
20.0	13.28
21.0	13.55
22.0	13.75
23.0	14.00
24.0	14.23
25.0	14.47
26.0	14.68
27.0	14.91
28.0	15.20
29.0	15.46
30.0	15.70
31.0	15.95

32.0	16.19
33.0	16.42
34.0	16.66
35.0	16.90

Note: 1. EER values at Medium Temperature Applications are based on a typical reciprocating compressor.
 2. Linear interpolation shall be used to calculate EER values for temperatures not shown in Table 1.

5.4 Alternate Component Indirect Effects. The revised Compressor Energy Consumption (CEC_R) is the indirect effect of alternate component(s) on the Compressor Energy Consumption (CEC) and shall be measured or calculated. The total revised Compressor Energy Consumption (CEC_R) is the sum of the CEC and the additional Compressor Energy Consumption (CEC_A) for each component.

$$CEC_R = CEC + \sum CEC_A \quad 14$$

5.4.1 Fans. When substituting a fan motor located in the refrigerated space, the change in energy affects the CEC. The change in CEC shall be calculated by multiplying the difference in power usage between the alternate components by the operating time and dividing by the compressor's EER rating. This change in CEC shall be added back to the original CEC:

$$CEC_A = 3.4121 \cdot [(P_s \cdot t_s) - (P_o \cdot t_o)] / (EER \cdot 1000) \quad 15$$

5.4.2 Lights. When substituting internal lighting located in the refrigerated space, the change in energy affects the CEC. The change in CEC shall be calculated by multiplying the difference in power usage between the alternate components by the operating time and dividing by the compressor's EER rating. This change in CEC shall be added back to the original CEC.

For ballast located internal or external to the refrigerated space:

$$CEC_A = 3.4121 \cdot [(P_s \cdot t_s) - (P_o \cdot t_o)] / (EER \cdot 1000) \quad 16$$

5.4.3 Anti-Condensate Heater. When substituting an anti-condensate heater located in the refrigerated space, the change in energy affects the CEC. The change in CEC shall be calculated by dividing the difference in energy usage between the alternate components by the compressor's EER rating. This change in CEC shall be added back to the original CEC:

$$CEC_A = 3.4121 \cdot [(P_s \cdot t_s) - (P_o \cdot t_o)] / (EER \cdot 1000) \quad 17$$

5.4.4 Condensate Evaporator Pans. When substituting a condensate evaporator pan located in the refrigerated space, the change in energy affects the CEC. The change in CEC shall be calculated by dividing the difference in energy usage between the alternate components by the compressor's EER rating.

This change in CEC shall be added back to the original CEC:

$$CEC_A = 3.4121 \cdot [(P_s \cdot t_s) - (P_o \cdot t_o)] / (EER \cdot 1000) \quad 18$$

5.5 Refrigerated Volume. The refrigerated volume of the Commercial Refrigerated Display Merchandiser or Storage Cabinet shall be calculated based on the equation below using the load line Volume as described in Appendix C:

$$V_r = A_r \cdot L \quad 19$$

5.6 Total Display Area. The total display area of the Commercial Refrigerated Display Merchandiser shall be calculated based on the equation below and as described in Appendix D:

$$TDA = (D_h \cdot L) + A_e \quad 20$$

5.7 *Tolerances.* To comply with this standard, published CDEC ratings shall be based on data obtained in accordance with this section, and shall be such that any production unit, when tested, shall not exceed these ratings by more than 5%. Values obtained using calculated component substitutions must also meet these tolerances.

5.8 *Multiples.* The CDEC, in kW·h per day, shall be expressed in 0.01 kW·h per day increments.

Section 6. Symbols and Subscripts

6.1 *Symbols and Subscripts.* The symbols and subscripts used in this standard are as follows:

A_e	=	Projected area from visible product through end walls, ft ²
A_r	=	Gross refrigerated area, ft ²
AEC	=	Anti-Condensate Energy Consumption, kW·h per day
CDEC	=	Calculated Daily Energy Consumption, kW·h per day
CEC	=	Compressor Energy Consumption, kW·h per day
CEC_A	=	Additional Compressor Energy Consumption for an alternate component, kW·h per day
CEC_R	=	Revised Compressor Energy Consumption, kW·h per day
CPEC	=	Circulation Pump Energy Consumption, kW·h per day
D_h	=	Dimension of projected visible product, ft
DEC	=	Defrost Energy Consumption, kW·h per day
EER	=	Energy Efficiency Ratio (Table 1), Btu/W·h
FEC	=	Fan Energy Consumption, kW·h per day
LEC	=	Light Energy Consumption, kW·h per day
LEC_R	=	Revised Light Energy Consumption, kW·h per day
L	=	Length of Refrigerated Space, ft
M	=	Secondary Coolant Flow Rate, gpm
n	=	Number of fan motors
P_{ai}	=	Power anti-condensate heater input, W
P_c	=	Power condensate evaporator pan heater input, W
P_d	=	Power defrost heater input, W
P_f	=	Power fan, W
P_{fi}	=	Power fan input, W
P_{fo}	=	Power fan output found on part nameplate, W
P_{li}	=	Power light input, W
P_o	=	Power input calculated for original part, W
P_s	=	Power input calculated for substitution part, W
PD	=	Secondary coolant pressure drop across merchandiser or cabinet, psi
PEC	=	Condensate Evaporator Pan Energy Consumption, kW·h per day
Q_{rt}	=	Commercial refrigerated display merchandiser or storage cabinet average refrigerator load for the running cycle(s) within the test (during total refrigerating time), Btu/h
Q_{CP}	=	Circulation Pump Heat Input, Btu/h
t	=	Time unit is tested in 24 h period, h
t_a	=	Time anti-condensate heaters are on in 24 hour period, h
t_c	=	Time condensate evaporator pan heaters are on in 24 hour period, h
t_d	=	Time defrost heaters are on in 24 hour period, h
t_{dt}	=	Time unit is in defrost, h
t_f	=	Time fans are on in 24 hour period, h
t_l	=	Time lights are on in 24 hour period, h
t_o	=	Time original part is on in 24 hour period, h
t_s	=	Time substitution part is on in 24 hour period, h
TDA	=	Total Display Area, ft ²
V_r	=	Refrigerated Volume, ft ³
η_m	=	Motor efficiency

Note: Per day denotes a 24-hour period.

Section 7. Minimum Data Requirements for Published Ratings

7.1 *Minimum Data Requirements for Published Ratings.* As a minimum, Published Ratings shall include all Standard Ratings. All claims to ratings within the scope of this standard shall include the statement "Rated in accordance with ANSI/AHRI Standard 1320 (I-P)". All claims to ratings outside the scope of this standard shall include the statement "Outside the scope of ANSI/AHRI Standard 1320 (I-P)". Wherever Application Ratings are published or printed, they shall include a statement of the conditions at which the ratings apply.

7.2 Table 2 represents the remote commercial refrigerated display merchandiser or storage cabinet data that shall be reported for each appropriate model(s).

Section 8. Marking and Nameplate Data

8.1 *Marking and Nameplate Data.* As a minimum, the following information shall be shown in a conspicuous place on the equipment:

- 8.1.1** Name or trade name of manufacturer
- 8.1.2** Manufacturer's model number
- 8.1.3** Heat transfer fluid (where appropriate)

Nameplate voltages for 60 Hertz systems are shown in Table 1 of AHRI Standard 110. Nameplate voltages for 50 Hertz systems shall include one or more of the utilization voltages shown in Table 1 of IEC Standard 60038. Tests shall be performed at the nameplate rated voltage and frequency unless otherwise specified in this standard. For all dual nameplate voltage equipment covered by this standard, tests shall be performed at both voltages or at the lower voltage if only a single rating is to be published.

Section 9. Conformance Conditions

9.1 *Conformance.* While conformance with this standard is voluntary, conformance shall not be claimed or implied for products or equipment within the standard's *Purpose* (Section 1) and *Scope* (Section 2) unless such product claims meet all of the requirements of the standard and all of the testing and rating requirements are measured and reported in complete compliance with the standard. Any product that has not met all the requirements of the standard shall not reference, state, or acknowledge the standard in any written, oral, or electronic communication.

Table 2. Presentation of Data for Remote Commercial Refrigerated Display Merchandisers and Storage Cabinets for Use with Secondary Refrigerants		
Item Number	Informational Item	Data
1	Model number	
2	Adjusted dew point (refrigerant), °F	
3	Load capacity, Q_{rt} , Btu/h	
4	Length of refrigerated space, L, ft	
5	Refrigerated volume, V_r , ft ³	
6	Total display area, TDA, ft ²	
7	Unit test voltage, Volts	
8	Secondary coolant inlet temperature, °F	
9	Integrated average temperature of product simulators, °F	
10	CEC, kW·h per day	
11	FEC, kW·h per day	
12	LEC, kW·h per day	
13	PEC, kW·h per day	
14	AEC, kW·h per day	
15	DEC, kW·h per day	
16	CDEC, kW·h per day	
17	CDEC/refrigerated volume, kW·h/ft ³ per day	
18	CDEC/total display area, kW·h/ft ² per day	
19	CPEC, circulation pump energy consumption, kW·h per day	
20	Q_{cp} , circulation pump heat input, Btu/h	
21	PD, secondary coolant pressure drop across merchandiser or cabinet, psi	
22	M, secondary coolant flow rate, gpm	
23	Other loads, notes:	

APPENDIX A. REFERENCES – NORMATIVE

A1 Listed here are all standards, handbooks, and other publications essential to the formation and implementation of the standard. All references in this appendix are considered as part of this standard.

A1.1 AHAM Standard HRF-1-2008, *Energy, Performance and Capacity of Household Refrigerators, Refrigerator-Freezers, and Freezers*, 2008 Association of Home Appliance Manufacturers, 1111 19th Street NW, Suite 402, Washington, DC 20036.

A1.2 AHRI Standard 110-2002, *Air-Conditioning and Refrigerating Equipment Nameplate Voltages*, 2002, Air-Conditioning, Heating, and Refrigeration Institute, 2111 Wilson Boulevard, Suite 500, Arlington, VA 22201, U.S.A.

A1.3 ANSI/ASHRAE Standard 72-2005, *Method of Testing Commercial Refrigerators and Freezers*, 2005, American Society of Heating, Refrigerating, and Air-Conditioning Engineers, Inc., 1791 Tullie Circle N.E., Atlanta, GA 30329, U.S.A.

A1.4 ASHRAE, *Terminology of Heating, Ventilation Air Conditioning and Refrigeration*, Second Edition, 1991, American Society of Heating, Refrigerating and Air-Conditioning Engineers, Inc., 1791 Tullie Circle N.E. Atlanta, GA 30329, U.S.A.

A1.5 IEC Standard 60038, *IEC Standard Voltages*, 2002, International Electrotechnical Commission, 3, rue de Varembe, P.O. Box 131, 1211 Geneva 20, Switzerland.

APPENDIX B. REFERENCES – INFORMATIVE

B1.1 10 CFR Part 431. "Energy Efficiency Program for Certain Commercial and Industrial Equipment." *U.S. Code of Federal Regulations*.

APPENDIX C. COMMERCIAL REFRIGERATED DISPLAY MERCHANDISERS AND STORAGE CABINETS FOR USE WITH SECONDARY REFRIGERANTS LOAD LINE VOLUME CALCULATION – NORMATIVE

C1 The commercial refrigerated display merchandiser refrigerated Volume (V_r) equals the gross refrigerated area (A_r) multiplied by the length of refrigerated space (L), as shown in Figure C1.1. The gross refrigerated area shall be calculated within the manufacturer’s specified load limit lines, without display devices installed in the Commercial Refrigerated Display Merchandiser, and shall be calculated using straight-line segments following the interior of the Commercial Refrigerated Display Merchandiser without display devices installed. The sample cross sections shown in Figure C1.2 shall be used as a guide in Equation C1.

$$V_r = A_r \cdot L$$

C1

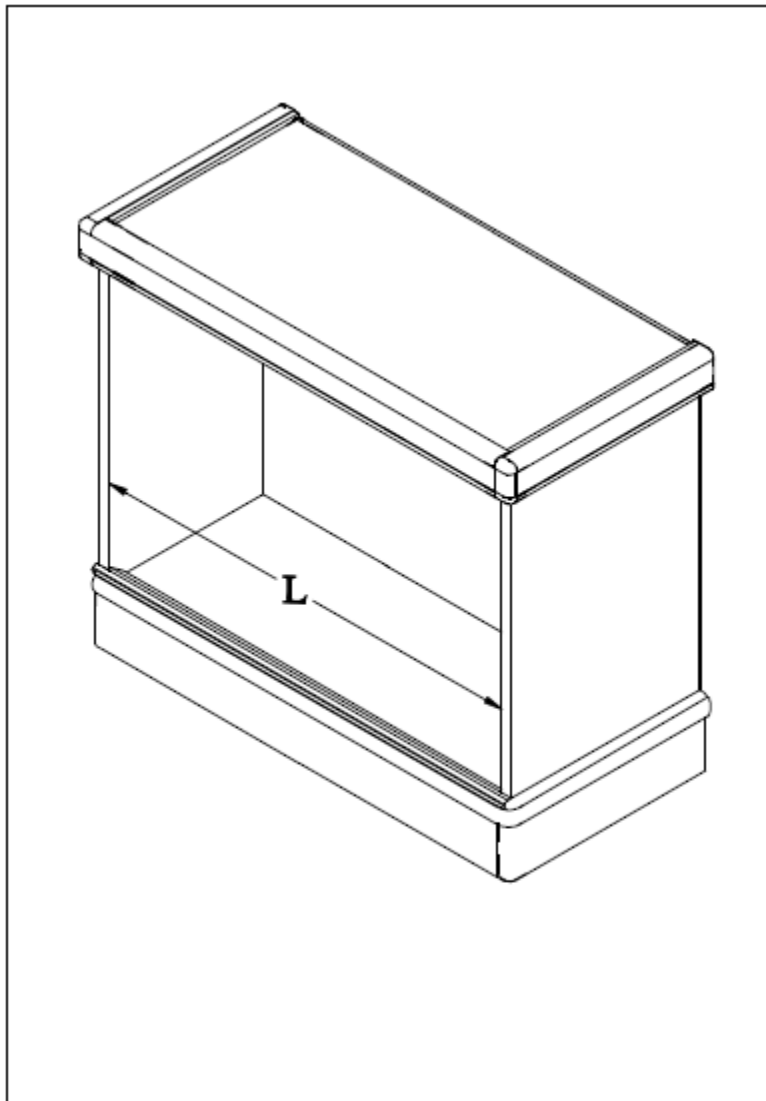

Figure C1.1: Sample Isometric View of Commercial Refrigerated Display Merchandisers for Illustrating Length of Refrigerated Space

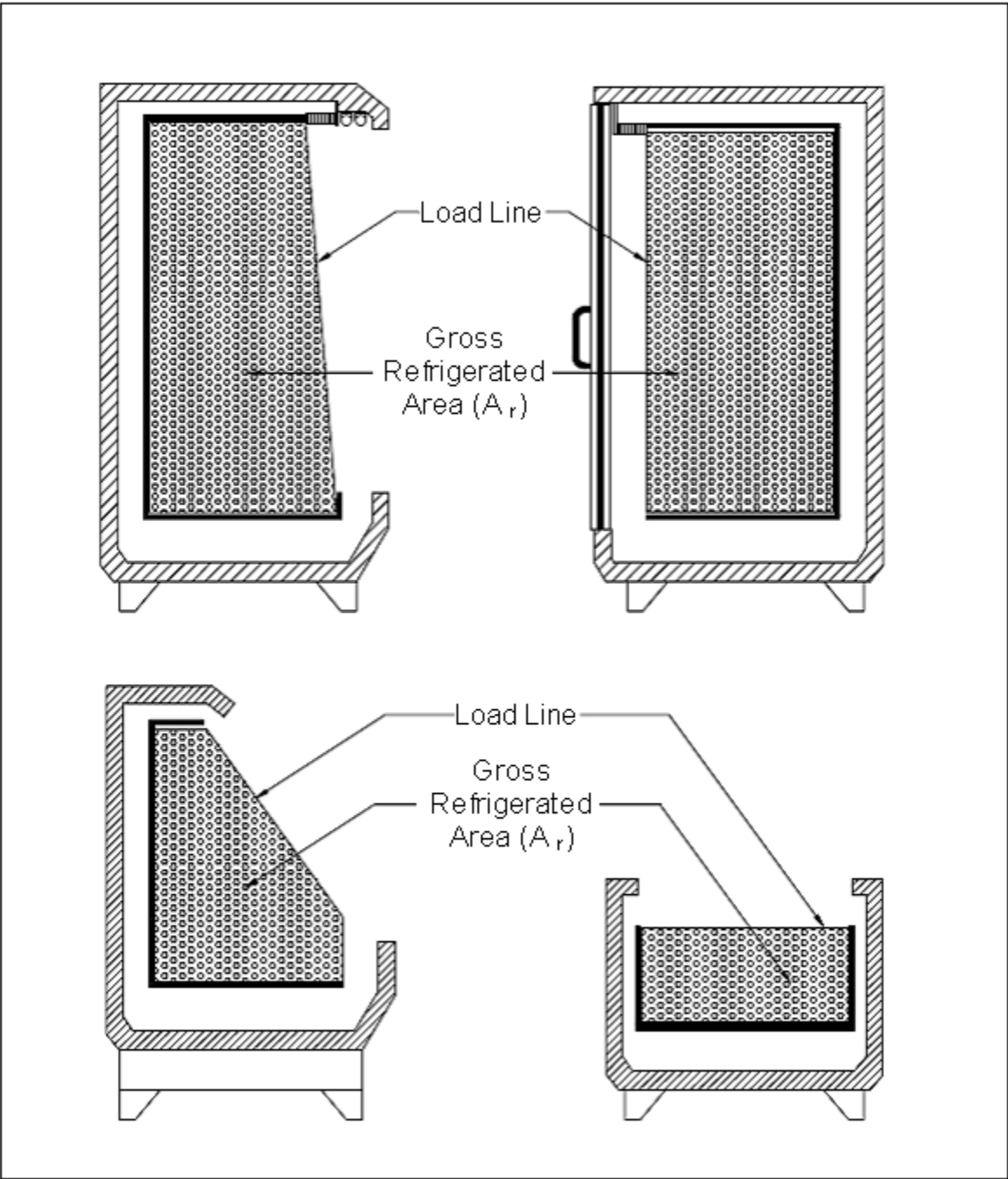

Figure C1.2: Sample Cross Sections of Commercial Refrigerated Display Merchandisers for Load Line Volume Calculation

C2 The commercial refrigerated storage cabinet refrigerated Volume (V_r) equals the gross refrigerated area (A_r) multiplied by the length of refrigerated space (L). The gross refrigerated area shall be calculated within the manufacturer's specified load limit. The gross refrigerated area shall be calculated using straight-line segments following the interior of the Commercial Refrigerated Storage Cabinet without display devices installed. The sample cross section in Figure C2 shall be used as a guide in Equation C1.

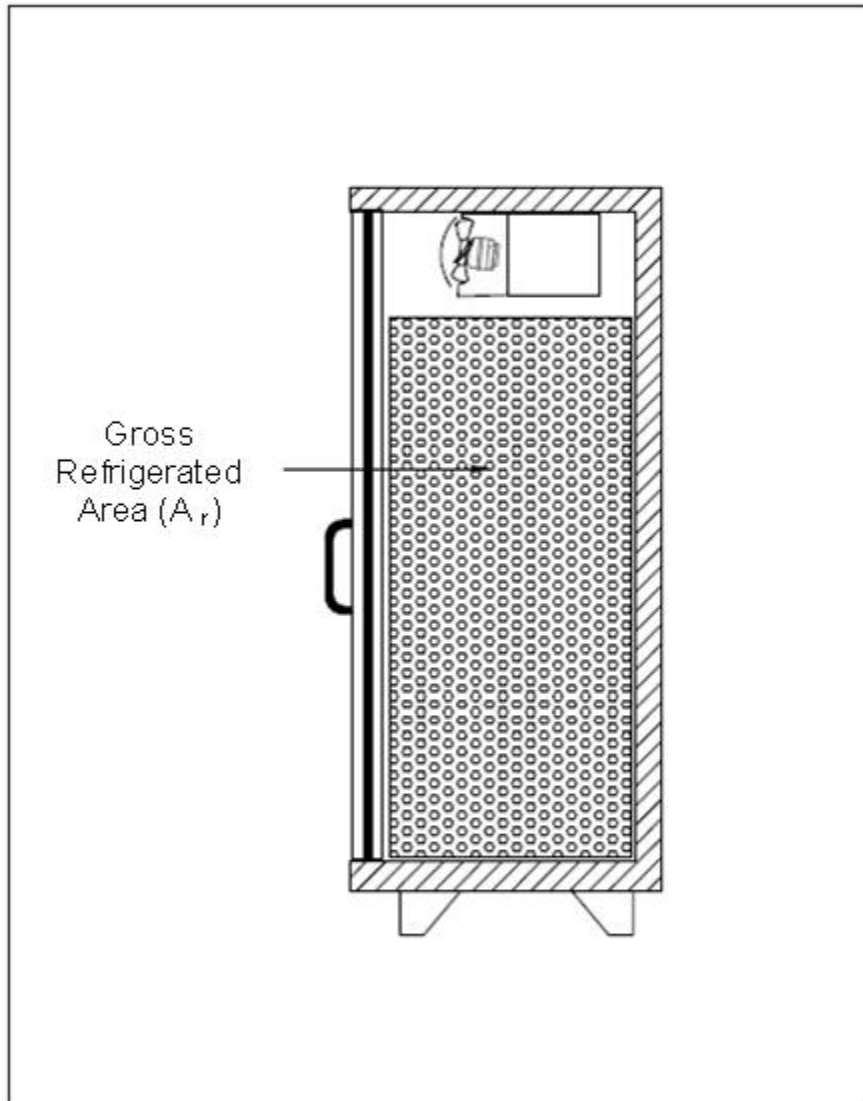

Figure C2: Sample Cross Section of Commercial Refrigerated Storage Cabinets for Volume Calculation

APPENDIX D. COMMERCIAL REFRIGERATED DISPLAY MERCHANDISERS FOR USE WITH SECONDARY REFRIGERANTS TOTAL DISPLAY AREA (TDA) CALCULATION – NORMATIVE

The Total Display Area (TDA) is the sum of the projected area(s) for visible product, ft².

$$TDA = D_h \cdot L + A_e$$

D1

A_e = Projected area from visible product through end walls (Figures D13 to D16)

D_h = Dimension of projected visible product (Figures D1 to D12)

L = Length of Commercial Refrigerated Display Merchandiser

Note: For unique geometries, the TDA shall be calculated manually. Refer to Figure D17.

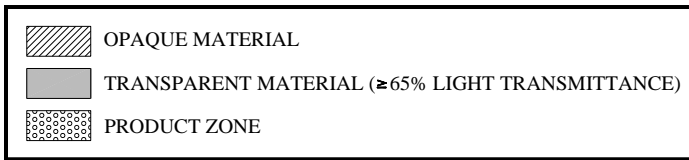

Nominal Length Display Merchandisers:

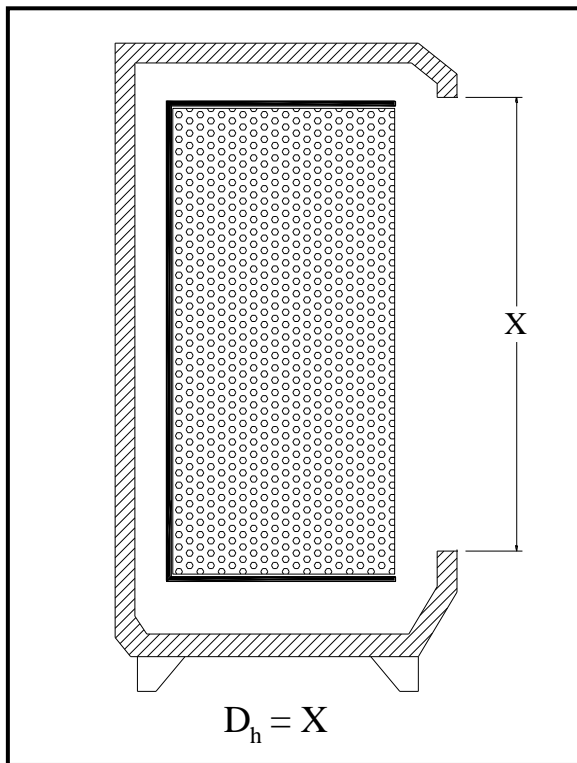

Figure D1: Vertical Open Multi-deck

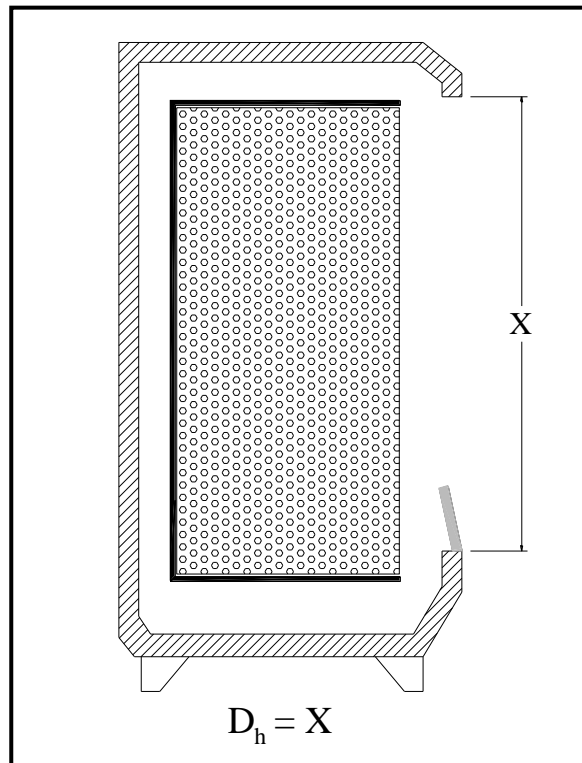

Figure D2: Vertical Open Multi-deck with Transparent Front

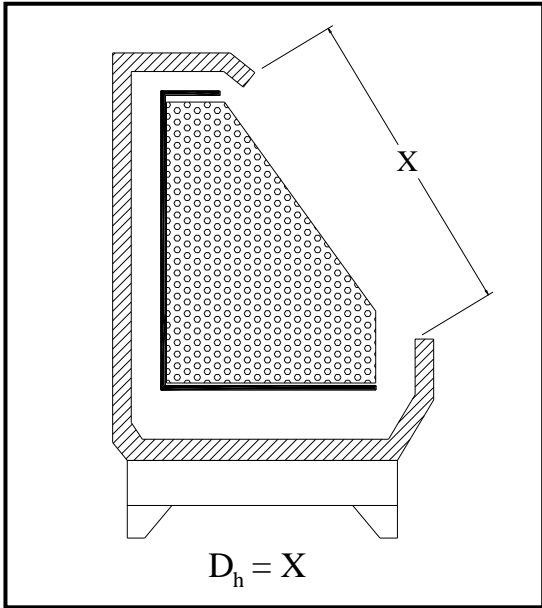

Figure D3: Semi-vertical Open Multi-deck

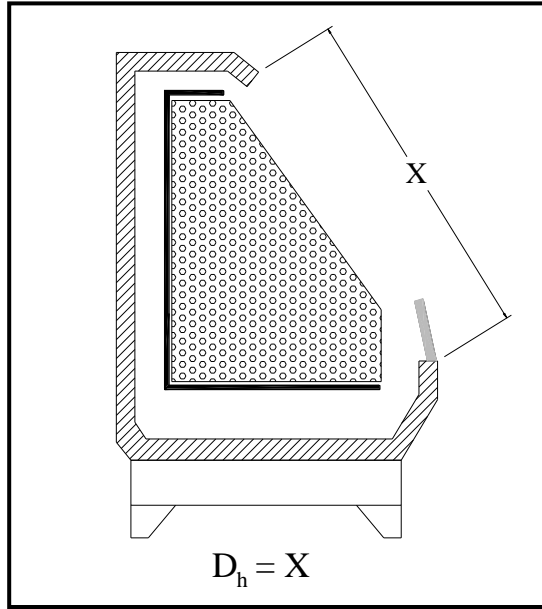

Figure D4: Semi-vertical Open Multi-deck with Transparent Front

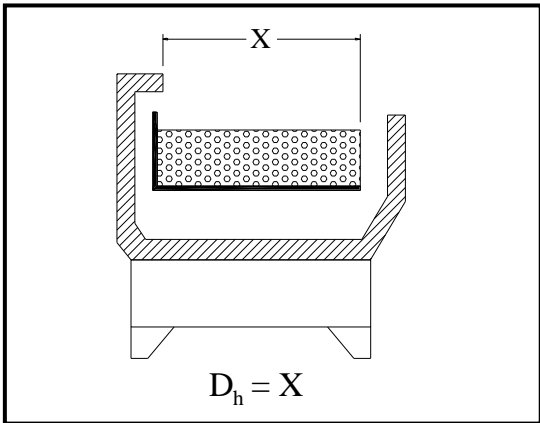

Figure D5: Horizontal Open Single-deck

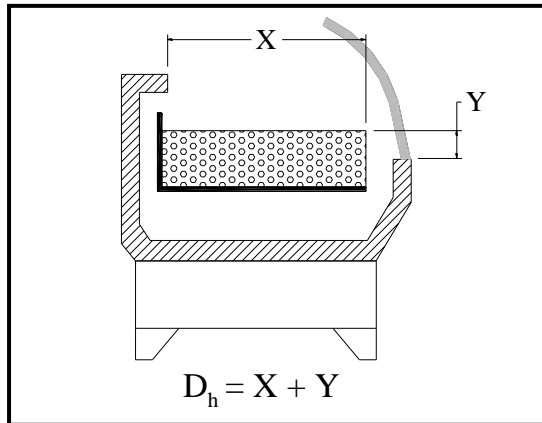

Figure D6: Horizontal Open Single-deck with Transparent Front

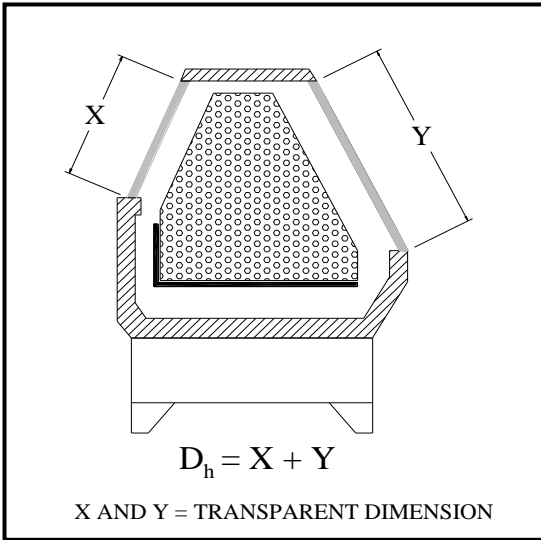

Figure D7: Service Over Counter with Flat Transparent Front

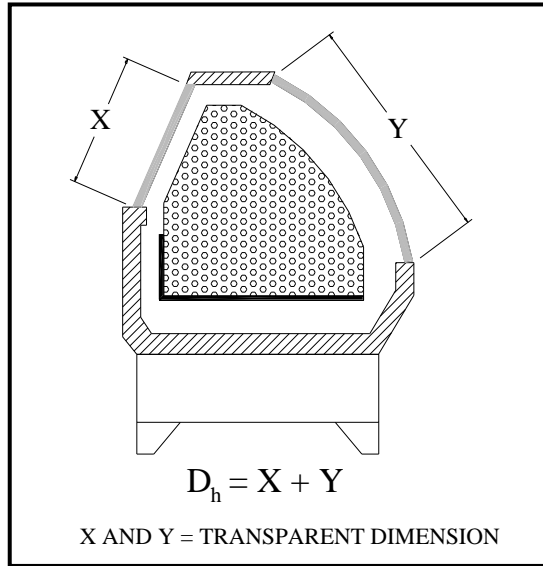

Figure D8: Service Over Counter with Curved Transparent Front

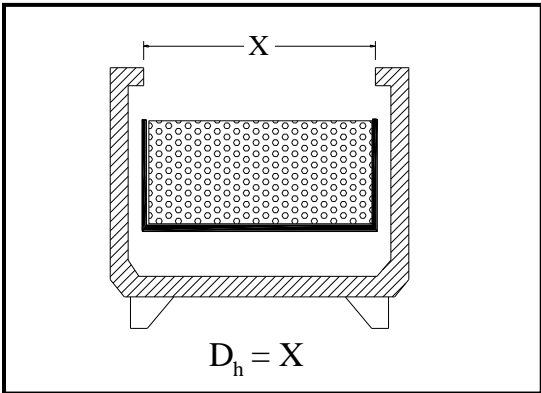

Figure D9: Horizontal Open Single-deck Island

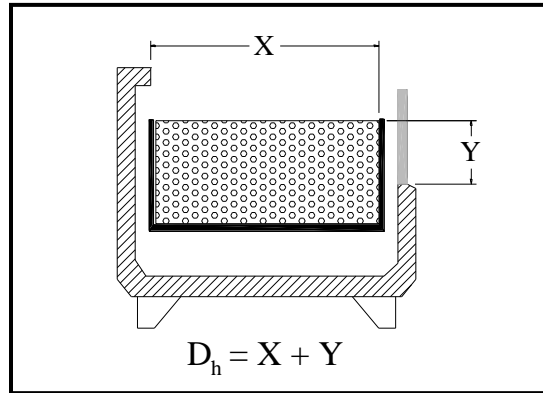

Figure D10: Horizontal Open Single-deck Island with Transparent Wall

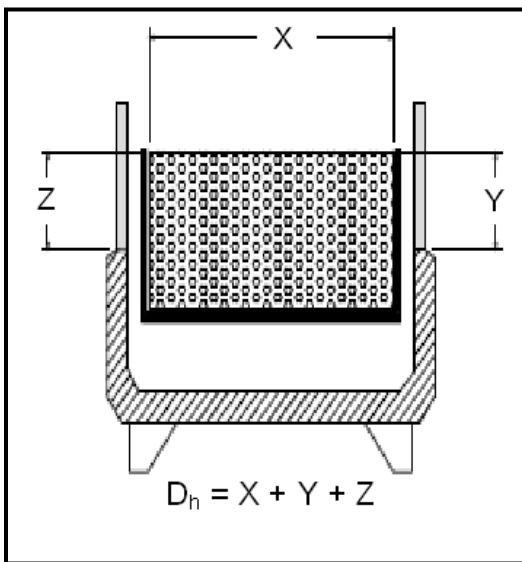

Figure D11: Horizontal Open Single-deck Island with Transparent Walls

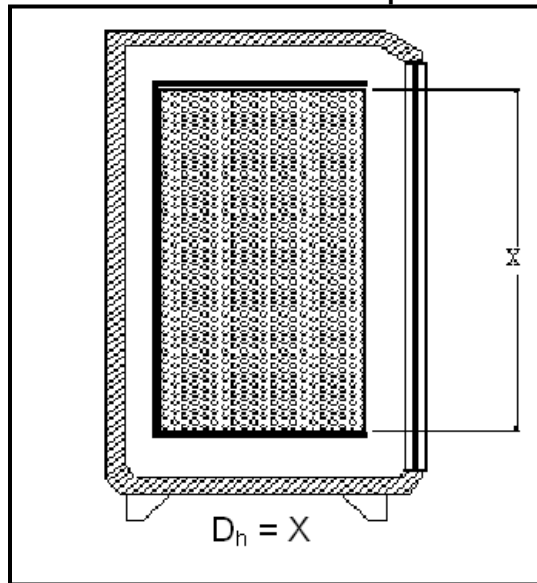

Figure D12: Vertical Closed Multi-deck with Transparent Doors

End Walls:

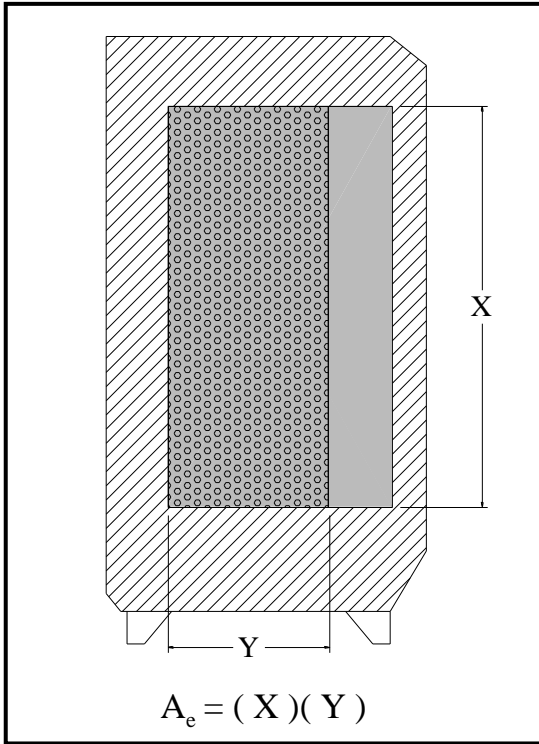

Figure D13: Vertical End Wall With Transparent Section

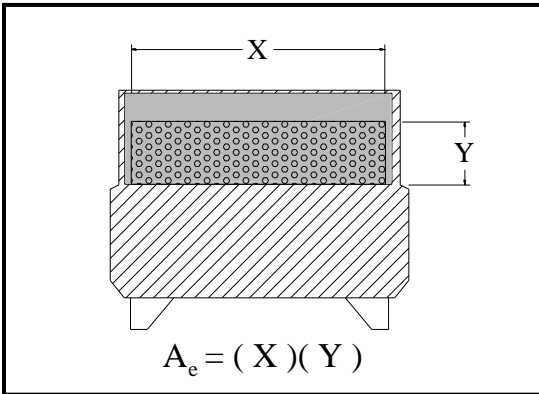

Figure D15: Horizontal Single-deck and Single-deck Island End Wall with Transparent Section

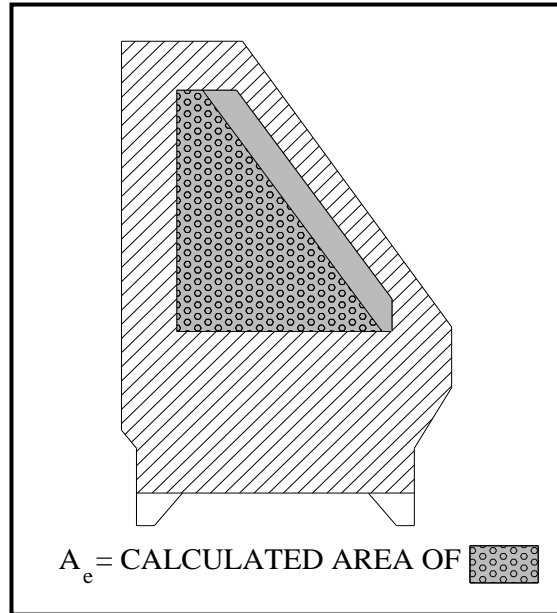

Figure D14: Semi-vertical End Wall with Transparent Section

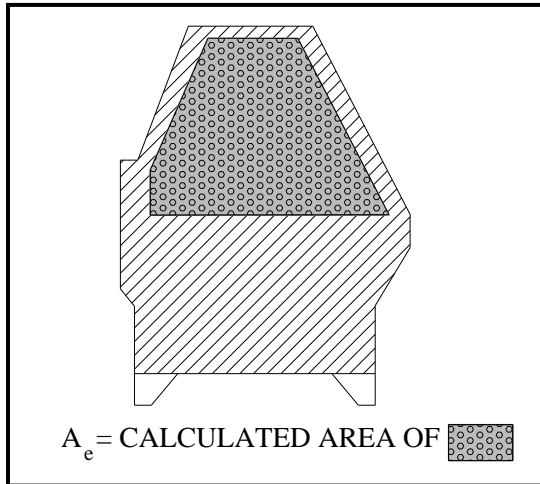

Figure D16: Service Over Counter End Wall with Transparent Section

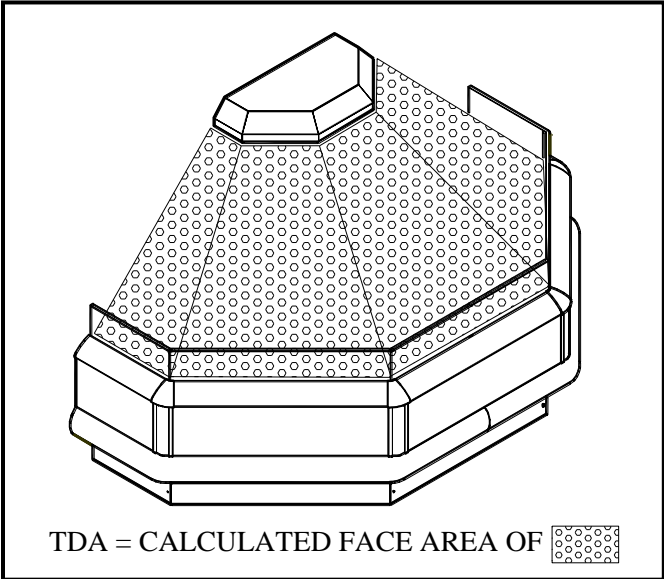

Figure D17: Example TDA for Unique Geometries

APPENDIX E. EXAMPLE – ENERGY PERFORMANCE REPRESENTATION FOR REMOTE COMMERCIAL REFRIGERATED DISPLAY MERCHANDISERS OR STORAGE CABINETS FOR USE WITH SECONDARY REFRIGERANTS– INFORMATIVE

E1 *Example of Performance Calculation and Presentation .*

E1.1 Situation. A manufacturer produces a remote commercial refrigerated display dairy merchandiser for use with a single-phase secondary coolant for Medium Temperature, Off-Cycle Defrost Applications in 4.0 ft, 6.0 ft, 8.0 ft, and 12.0 ft lengths. The gross refrigerated area of these cases is 11.67 ft² and the dimension of projected visible product is 4.35 ft. The cross-sections of all cases with this model are identical. The display case is rated at 120 V.

E1.2 Measured Results (per ANSI/ASHRAE Standard 72 Energy Calculations).

- Remote unit 12.0 ft long (actual length of refrigerated space) with two solid end walls.
- Capacity load: 16,400 Btu/h at 20.0°F secondary coolant inlet temperature
- Secondary coolant flow rate = 5.9 GPM
- Secondary coolant pressure drop across merchandiser = 7.5 psi
- Integrated Average Temperature = 37.6°F
- Fan power = 60 W (fans on during defrost)
- Anti-condensate power = 0 W
- Lighting watts = 294 W (located in the refrigerated space)
- Electric defrost power = 0 W (off cycle)
- Condensate pan power = 0 W (none)
- Number of defrosts in 24 h = 4
- Length of each defrost = 0.6 h

E1.3 Energy Performance Calculations.

E1.3.1 Calculation of Refrigerated Volume.

$$\begin{aligned}
 V_r &= A_r \cdot L \\
 &= 11.67 \cdot 12.0 = 140.04 \text{ ft}^3
 \end{aligned}
 \tag{E1}$$

E1.3.2 Calculation of TDA.

$$\begin{aligned}
 TDA &= (D_h \cdot L) + A_e \\
 &= (4.35 \cdot 12) + 0 = 52.20 \text{ ft}^2
 \end{aligned}
 \tag{E2}$$

E1.3.3 Calculation of CPEC.

$$\begin{aligned}
 CPEC &= [M \cdot 9.4 + M \cdot (PD - 6.5) \cdot 0.65] \cdot (t - t_{dt}) / 1000 \\
 &= [5.9 \cdot 9.4 + 5.9 \cdot (7.5 - 6.5) \cdot 0.65] \cdot (24 - 2.4) / 1000 \\
 &= 1.28 \text{ kW} \cdot \text{h per day}
 \end{aligned}
 \tag{E3}$$

E1.3.4 Calculation of Q_{CP}.

$$\begin{aligned}
 Q_{CP} &= CPEC \cdot 0.9 \cdot 3412 / (t - t_{dt}) \\
 &= 1.28 \cdot 0.9 \cdot 3412 / (24 - 2.4) \\
 &= 182 \text{ Btu/h}
 \end{aligned}
 \tag{E4}$$

E1.3.5 *Calculation of CEC.*

EER (Table 1) based on 14.0°F Adjusted Dew Point (20.0°F for Medium Temperature Applications) = 12.02

Defrost total time = 4 x 0.6 = 2.4 h

$$\begin{aligned} \text{CEC} &= [(Q_{it} + Q_{CP}) \cdot (t - t_{dt})] / (\text{EER} \cdot 1000) && \text{E5} \\ &= [(16,400 + 182) \cdot (24 - 2.4)] / (12.02 \cdot 1000) \\ &= 29.8 \text{ kW}\cdot\text{h per day} \end{aligned}$$

E1.3.6 *Calculation of FEC.*

$$\begin{aligned} \text{FEC} &= (P_{fi} \cdot t_f) / (1000) && \text{E6} \\ &= (60 \cdot 24) / (1000) \\ &= 1.44 \text{ kW}\cdot\text{h per day} \end{aligned}$$

E1.3.7 *Calculation of LEC.*

$$\begin{aligned} \text{LEC} &= (P_{li} \cdot t_l) / (1000) && \text{E7} \\ &= (294 \cdot 24) / (1000) \\ &= 7.06 \text{ kW}\cdot\text{h per day} \end{aligned}$$

E1.3.8 *Calculation of AEC.*

$$\text{AEC} = 0 \text{ kW}\cdot\text{h per day} \quad \text{E8}$$

E1.3.9 *Calculation of DEC.*

$$\text{DEC} = 0 \text{ kW}\cdot\text{h per day} \quad \text{E9}$$

E1.3.10 *Calculation of PEC.*

$$\text{PEC} = 0 \text{ kW}\cdot\text{h per day} \quad \text{E10}$$

E1.3.11 *Calculation of CDEC.*

$$\begin{aligned} \text{CDEC} &= \text{CEC} + \text{FEC} + \text{LEC} + \text{AEC} + \text{DEC} + \text{PEC} + \text{CPEC} && \text{E11} \\ &= 29.8 + 1.44 + 7.06 + 0 + 0 + 0 + 1.28 \\ &= 39.58 \text{ kW}\cdot\text{h per day} \end{aligned}$$

E1.4 *Presentation of CDEC Data.* Refer to Table E1 for correct display of performance data.

E2 *Example of Performance Calculation and Presentation with Component Substitution.*

E2.1 *Situation.* The manufacturer of the case in the situation shown in Section E1 substitutes the lamp ballasts with new ballasts.

E2.2 *Nameplate Data.* The original ballast had a nameplate rating of 294 W. The new ballast has a nameplate rating of 360 W.

E2.3 *Energy Performance Calculations with Component Substitution.*

E2.3.1 *Calculation of Revised Light Energy Consumption.*

$$\begin{aligned} \text{LEC}_R &= (P_s \cdot t_s) / (1000) && \text{E12} \\ &= (360 \cdot 24) / (1000) \\ &= 8.64 \text{ kW}\cdot\text{h per day} \end{aligned}$$

E2.3.2 Calculation of revised Compressor Energy Consumption.

E.2.3.2.1 Calculation of CEC_A .

$$\begin{aligned}
 CEC_A &= 3.4121 \cdot [(P_s \cdot t_s) - (P_o \cdot t_o)] / (EER \cdot 1000) && E13 \\
 &= 3.4121 \cdot [(360 \cdot 24) - (294 \cdot 24)] / (12.02 \cdot 1000) \\
 &= 0.45 \text{ kW}\cdot\text{h per day}
 \end{aligned}$$

E.2.3.2.2. Calculation of CEC_R .

$$\begin{aligned}
 CEC_R &= CEC + CEC_A && E14 \\
 &= 29.8 + 0.45 \\
 &= 30.25 \text{ kW}\cdot\text{h per day}
 \end{aligned}$$

E.2.3.2.3. Calculation of Revised CDEC.

$$\begin{aligned}
 CDEC &= CEC_R + FEC + LEC_R + AEC + DEC + PEC + CPEC && E15 \\
 &= 30.25 + 1.44 + 8.64 + 0 + 0 + 1.28 \\
 &= 41.61 \text{ kW}\cdot\text{h per day}
 \end{aligned}$$

Table E1. Sample Presentation of Data for Remote Commercial Refrigerated Display Merchandisers and Storage Cabinets for Use With Secondary Refrigerants

Item Number	Informational Item	Data
1	Model number	Model X
2	Adjusted dew point (Refrigerant), °F	14.0
3	Load capacity, Q_{rt} , Btu/h	16,400
4	Length of refrigerated space, L, ft	12
5	Refrigerated volume, V_r , ft ³	140.04
6	Total display area, TDA, ft ²	52.20
7	Unit test voltage, Volts	120
8	Secondary coolant inlet temperature, °F	20.0
9	Integrated average temperature of product simulators, °F	37.6
10	CEC, kW·h per day	29.8
11	FEC, kW·h per day	1.44
12	LEC, kW·h per day	7.06
13	PEC, kW·h per day	N/A
14	AEC, kW·h per day	0.0
15	DEC, kW·h per day	0.0
16	CDEC, kW·h per day	39.58
17	CDEC/refrigerated volume, kW·h/ft ³ per day	0.28
18	CDEC/total display area, kW·h/ft ² per day	0.76
19	CPEC, circulation pump energy consumption, kW·h per day	1.28
20	Q_{CP} , circulation pump heat input, Btu/h	182
21	PD, secondary coolant pressure drop across merchandiser or cabinet, psi	7.5
22	M, secondary coolant flow rate, gpm	5.9
23	Other loads, notes:	