

ANSI/AHRI Standard 1251 (SI)

2014 Standard for Performance Rating of Walk-in Coolers and Freezers



Approved by ANSI on May 19, 2015



**Air-Conditioning, Heating,
and Refrigeration Institute**

2111 Wilson Boulevard, Suite 500
Arlington, VA 22201, USA
www.ahrinet.org

PH 703.524.8800
FX 703.562.1942

ERRATA SHEET FOR ANSI/AHRI STANDARD 1251 (SI)-2014, *PERFORMANCE RATING OF WALK-IN COOLERS AND FREEZERS*

December 2015

The corrections listed in this errata sheet apply to ANSI/AHRI Standard 1251 (SI)-2014.

| Page | Erratum |
|------|--|
| 27 | <p>Equation 67. The temperature term t_{IHH} in the denominator of Equation 67 must be changed to t_{VH}. This was a typo that must be corrected. The correction only applies to the second instance of t_{IHH} in the denominator.</p> <p>Current equation: $b = \frac{EER_{SS}^{k=1}(t_{IH}) - EER_{SS}^{k=2}(t_{IHH}) - d[EER_{SS}^{k=1}(t_{IH}) - EER_{SS}^{k=i}(t_{VH})]}{t_{IH} \cdot t_{IHH} - d[t_{IH} \cdot t_{IHH}]}$ 67</p> <p>New equation: $b = \frac{EER_{SS}^{k=1}(t_{IH}) - EER_{SS}^{k=2}(t_{IHH}) - d[EER_{SS}^{k=1}(t_{IH}) - EER_{SS}^{k=i}(t_{VH})]}{t_{IH} \cdot t_{IHH} - d[t_{IH} \cdot t_{VH}]}$ 67</p> <p>t_{VH}: The outdoor temperature at which the unit, when operating at the intermediate capacity that is tested under the designated condition, provides a refrigeration capacity that is equal to the total walk-in system heat load during high load period, °F</p> <p>t_{IHH}: The outdoor temperature at which the total walk-in system heat load equals system net capacity when the compressor operates at high or maximum capacity ($k=2$) during the high load period, °F</p> |

| Page | Erratum |
|------|--|
| 28 | <p>Equation 83. The temperature term t_{IHH} in the denominator of Equation 83 must be changed to t_{VL}. This was a typo that must be corrected. The correction only applies to the second instance of t_{IHH} in the denominator.</p> <p>Current equation: $b = \frac{EER_{SS}^{k=1}(t_{IH}) - EER_{SS}^{k=2}(t_{IHH}) - d[EER_{SS}^{k=1}(t_{IH}) - EER_{SS}^{k=i}(t_{VL})]}{t_{IH} \cdot t_{IHH} - d[t_{IH} \cdot t_{IHH}]}$ 83</p> <p>New equation: $b = \frac{EER_{SS}^{k=1}(t_{IH}) - EER_{SS}^{k=2}(t_{IHH}) - d[EER_{SS}^{k=1}(t_{IH}) - EER_{SS}^{k=i}(t_{VL})]}{t_{IH} \cdot t_{IHH} - d[t_{IH} \cdot t_{VL}]}$ 83</p> <p>t_{VL}: The outdoor temperature at which the unit, when operating at the intermediate capacity that is tested under the designated condition, provides a refrigeration capacity that is equal to the total walk-in system heat load during low load period, °F</p> <p>t_{IHL}: The outdoor temperature at which the total walk-in system heat load equals system net capacity when the compressor operates at high or maximum capacity ($k=2$) during the low load period, °F</p> |

IMPORTANT

SAFETY DISCLAIMER

AHRI does not set safety standards and does not certify or guarantee the safety of any products, components or systems designed, tested, rated, installed or operated in accordance with this standard/guideline. It is strongly recommended that products be designed, constructed, assembled, installed and operated in accordance with nationally recognized safety standards and code requirements appropriate for products covered by this standard/guideline.

AHRI uses its best efforts to develop standards/guidelines employing state-of-the-art and accepted industry practices. AHRI does not certify or guarantee that any tests conducted under its standards/guidelines will be non-hazardous or free from risk.

Note:

This standard supersedes AHRI Standard 1251 (SI)-2009
For I-P ratings, see ANSI/AHRI Standard 1250 (I-P)-2014.

TABLE OF CONTENTS

| | PAGE |
|---|-------------|
| Section 1. Purpose..... | 1 |
| Section 2. Scope..... | 1 |
| Section 3. Definitions..... | 1 |
| Section 4. Test Requirements..... | 3 |
| Section 5. Rating Requirements..... | 5 |
| Section 6. Calculation for Walk-in Box Load..... | 19 |
| Section 7. Calculation for Annual Walk-in Energy Factor | 20 |
| Section 8. Symbols and Subscripts | 42 |
| Section 9. Minimum Data Requirements for Published Ratings..... | 45 |
| Section 10. Marking and Nameplate Data | 45 |
| Section 11. Conformance Conditions..... | 45 |

TABLES

| | |
|--|----|
| Table 1. Instrumentation Accuracy | 3 |
| Table 2. Test Operating and Test Condition Tolerances for Steady-state Test | 4 |
| Table 3. Fixed Capacity Matched Refrigerator System, Condensing Unit Located Indoor | 5 |
| Table 4. Fixed Capacity Matched Refrigerator System, Condensing Unit Located Outdoor | 5 |
| Table 5. Two Capacity Matched Refrigerator System, Condensing Unit Located Outdoor | 6 |
| Table 6. Variable Capacity Matched Refrigerator System, Condensing Unit Located Outdoor..... | 8 |
| Table 7. Fixed Capacity Matched Freezer System, Condensing Unit Located Indoor..... | 10 |
| Table 8. Fixed Capacity Matched Freezer System, Condensing Unit Located Outdoor | 10 |
| Table 9. Two Capacity Matched Freezer System, Condensing Unit Located Outdoor..... | 11 |
| Table 10. Variable Capacity Matched Freezer System, Condensing Unit Located Outdoor | 14 |
| Table 11. Fixed Capacity Refrigerator Condensing Unit, Condensing Unit Located Indoor..... | 16 |
| Table 12. Fixed Capacity Refrigerator Condensing Unit, Condensing Unit Located Outdoor | 16 |
| Table 13. Fixed Capacity Freezer Condensing Unit, Condensing Unit Located Indoor | 17 |
| Table 14. Fixed Capacity Freezer Condensing Unit, Condensing Unit Located Outdoor | 17 |

TABLES (continued)

| | PAGE |
|-----------|--|
| Table 15. | Refrigerator Unit Cooler 18 |
| Table 16. | Freezer Unit Cooler..... 18 |
| Table 17. | EER for Remote Commercial Refrigerated Display Merchandisers and Storage Cabinets 31 |
| Table 18. | Unit Cooler Nominal Values for Condensing Unit Energy Calculations 34 |

FIGURES

| | |
|-----------|--|
| Figure 1. | Schematic of the Operation for Units with Single Capacity Compressor 21 |
| Figure 2. | Schematic of the Various Modes of Operation for Units with Two Capacity or Two-Stage Compressors .. 23 |
| Figure 3. | Schematic of the Various Modes of Operation for units with Variable Speed Compressors 26 |

APPENDICES

| | |
|-------------|--|
| Appendix A. | References – Normative 46 |
| Appendix B. | References – Informative 48 |
| Appendix C. | Methods of Testing Walk-in Cooler and Freezer Systems – Normative 49 |
| Appendix D. | Weather Data in Region IV – Normative 62 |

TABLES FOR APPENDICES

| | |
|-----------|---|
| Table C1. | Test Readings 51 |
| Table C2. | Data to be Recorded 53 |
| Table C3. | Unit Cooler Nominal Values for Condensing Unit Energy Calculations 61 |
| Table D1. | Bin Temperatures and Corresponding Bin Hours for AWEF Calculation 62 |

FIGURES FOR APPENDICES

| | |
|------------|--|
| Figure C1. | Method 1: DX-Dual Instrumentation 54 |
| Figure C2. | Method 2: DX- Calibrated Box 55 |

PERFORMANCE RATING OF WALK IN COOLERS AND FREEZERS

Section 1. Purpose

1.1 Purpose. The purpose of this standard is to establish, for walk-in coolers and freezers: definitions; test requirements; rating requirements; minimum data requirements for Published Ratings; operating requirements; marking and nameplate data and conformance conditions.

1.1.1 Intent. This standard is intended for the guidance of the industry, including manufacturers, designers, installers, contractors and users.

1.1.2 Review and Amendment. This standard is subject to review and amendment as technology advances.

Section 2. Scope

2.1 Scope. This standard applies to mechanical refrigeration equipment consisting of an integrated single package refrigeration unit, or separate Unit Cooler and condensing unit sections, where the condensing section can be located either outdoor or indoor. Controls may be integral, or can be provided by a separate party as long as performance is tested and certified with the listed mechanical equipment accordingly.

2.2 Exclusions. This standard does not apply to:

2.2.1 Enclosures used for telecommunications switch gear or other equipment requiring cooling

2.2.2 Enclosures designed for medical, scientific or research purposes

2.2.3 Performance testing and efficiency characterization of large parallel rack refrigeration systems (condensing unit)

Section 3. Definitions

All terms in this document will follow the standard industry definitions in the *ASHRAE Terminology* website (<https://www.ashrae.org/resources--publications/free-resources/ashrae-terminology>) unless otherwise defined in this section.

3.1 Annual Walk-in Energy Factor (AWEF). A ratio of the total heat, not including the heat generated by the operation of refrigeration systems, removed, in watt-hours, from a walk-in box during one year period of usage for refrigeration to the total energy input of refrigeration systems, in watt-hours, during the same period.

3.2 Coefficient of Performance (COP). A ratio of the Net Refrigeration Capacity in W to the power input values in W at any given set of Rating Conditions expressed in W/W.

3.3 Forced-circulation Free-Delivery Unit Coolers (Unit Coolers). A factory-made assembly, including means for forced air circulation and elements by which heat is transferred from air to refrigerant without any element external to the cooler imposing air resistance. These may also be referred to as Air Coolers, Cooling Units, Air Units or Evaporators.

3.4 Gross Refrigeration Capacity. The heat absorbed by the refrigerant, W. This is the sum of the Net Refrigeration Capacity and the heat equivalent of the energy required to operate the Unit Cooler. This includes both sensible and latent cooling.

3.5 Load Factor. A ratio of the Total Walk-in System Heat Load to the steady-state net refrigeration capacity.

3.6 Load Period. A twenty-four hour day.

3.6.1 High Load Period. The period of the day corresponding to frequent door openings, product loading events, and other design Load Factors. For the purposes of this standard, this period shall be 8 continuous hours.

3.6.2 Low Load Period. The period of the day other than the High Load Period. For the purposes of this standard, this period shall be the remaining 16 continuous hours of the total Load Period.

3.7 Net Refrigeration Capacity. The refrigeration capacity available for space and product cooling, W. It is equal to the Gross Refrigeration Capacity less the heat equivalent of energy required to operate the Unit Cooler (e.g.: evaporator fans, defrost)

3.8 Positive Displacement Condensing Unit. A specific combination of refrigeration system components for a given refrigerant, consisting of one or more electric motor driven positive displacement compressors, condensers, and accessories as provided by the manufacturer.

3.9 Published Rating. A statement of the assigned values of those performance characteristics, under stated rating conditions, by which a unit may be chosen to fit its application. These values apply to all units of like nominal size and type (identification) produced by the same manufacturer. The term Published Rating includes the rating of all performance characteristics shown on the unit or published in specifications, advertising or other literature controlled by the manufacturer, at stated Rating Conditions.

3.9.1 Application Rating. A rating based on tests performed at application Rating Conditions, (other than Standard Rating Conditions).

3.9.2 Standard Rating. A rating based on tests performed at Standard Rating Conditions.

3.10 Rated Fan Power.

3.10.1 For single phase motors, total fan motor input power, W.

3.10.2 For polyphase motors, individual fan motor output power, W.

3.11 Rating Conditions. Any set of operating conditions under which a single level of performance results and which causes only that level of performance to occur.

3.11.1 Standard Ratings Conditions. Rating conditions used as the basis of comparison for performance characteristics.

3.12 Refrigeration Capacity. The capacity associated with the increase in total enthalpy between the liquid refrigerant entering the expansion valve and superheated return gas multiplied by the mass flow rate of the refrigerant.

3.13 "Shall" or "Should". "Shall" or "should" shall be interpreted as follows:

3.13.1 Shall. Where "shall" or "shall not" is used for a provision specified, that provision is mandatory if compliance with the standard is claimed.

3.13.2 Should. "Should," is used to indicate provisions which are not mandatory, but which are desirable as good practice.

3.14 Refrigerant Saturation Temperature. Refrigerant temperature at the Unit Cooler inlet or outlet determined either by measuring the temperature at the outlet of the two-phase refrigerant flow, for a Liquid Overfeed Unit Cooler, or by measuring refrigerant pressure and determining the corresponding temperature from reference thermodynamic tables or equations for the refrigerant, °C. For zeotropic refrigerants, the corresponding temperature to a measured pressure is the refrigerant Dew Point.

3.15 Steady-state. An operating state of a system, including its surroundings, in which the extent of change with time is within the required limits within this standard.

3.16 Test Measurement. The reading of a specific test instrument at a specific point in time. The Test Measurement may be averaged with other measurements of the same parameter at the same time to determine a Test Reading or averaged over the duration of the test to determine the value for the Test Run. Refer to Table C1 for Test Reading minimum time rate, number of Test Readings and minimum test duration.

3.17 Test Reading. The recording of one full set of the Test Measurements required to assess the performance of the test unit.

3.18 Total Walk-in System Heat Load. Total heat load to the walk-in system including Walk-in Box Load and the heat load to the box contributed by the operation of the refrigeration system.

3.18.1 Walk-in System High Load (WLH). Total Walk-in System Heat Load during a High Load Period.

3.18.1 Walk-in System Low Load (WLL). Total Walk-in System Heat Load during a Low Load Period.

3.19 Volatile Refrigerant. A refrigerant which changes from liquid to vapor in the process of absorbing heat.

3.20 Walk-in Box Load. Heat load to the walk-in box resulting from conduction, infiltration and internal heat gains from equipment that is not related to the refrigeration system, such as lights and anti-sweat heaters, etc.

3.20.1 High Box Load (BLH). Walk-in Box Load during a High Load Period.

3.20.2 Low Box Load (BLL). Walk-in Box Load during a Low Load Period.

Section 4. Test Requirements

4.1 Instruments. All measuring instruments shall be selected to meet or exceed the accuracy criteria listed in Table 1 for each type of measurement. All temperature measurement shall be made in accordance with Table 2, Test Tolerance. Precision instruments and automated electronic data acquisition equipment shall be used to measure and record temperature, pressure and refrigerant flow rate test parameters. All measuring instruments and instrument systems (e.g. data acquisition coupled to temperature, pressure, or flow sensors) shall be calibrated by comparison to primary or secondary standards with calibrations traceable to National Institute of Standards and Technology (NIST) measurements, other recognized national laboratories, or derived from accepted values of natural physical constants. All test instruments shall be calibrated annually, whenever damaged, or when the accuracy is called into question.

| Measurement | Medium | Minimum Accuracy |
|--------------------------------|--|--|
| Temperature, °C | Air dry-bulb | ± 0.3 |
| | Air wet-bulb | |
| | Refrigerant liquid | |
| | Refrigerant vapor | ± 0.3 |
| | Air Dew Point | ± 0.3 |
| | Others, °C | ± 0.6 |
| Relative humidity ¹ | Air | ± 3 % points rh |
| Pressure | Refrigerant | Pressure corresponding to ± 0.1 °C of saturation temperature |
| | Air | ± 169 Pa |
| Flow | Refrigerant | 1 % of reading |
| | Liquids | 1 % of reading |
| Electrical | Motor kilowatts/amperes/voltage | 1 % of reading |
| | Auxiliary kilowatt input (e.g. heater) | |

| Table 1. Instrumentation Accuracy (cont.) | | |
|--|----------------------------|------------------------|
| Measurement | Medium | Minimum Accuracy |
| Speed | Motor / fan shaft | 1 % of reading |
| Weight | Oil / refrigerant solution | 0.5 % of reading |
| Specific Gravity | Brine | 1 % of reading |
| Time | Hours / minutes / seconds | 0.5 % of time interval |
| Note: 1. Relative humidity and air dew point measurements are intended to confirm the dry coil condition. | | |

| Table 2. Test Operating and Test Condition Tolerances for Steady-state Test | | |
|---|---------------------------------------|---------------------------------------|
| | Test Operating Tolerance ¹ | Test Condition Tolerance ² |
| Indoor dry-bulb, °C | | |
| Entering temperature | ± 2.0 | ± 0.3 |
| Indoor wet-bulb, °C | | |
| Entering temperature | ± 2.0 | ± 0.3 |
| Outdoor dry-bulb, °C | | |
| Entering temperature | ± 2.0 | ± 0.6 |
| Outdoor wet-bulb, °C | | |
| Entering temperature | ± 2.0 | ± 0.6 |
| Electrical voltage, % of reading. | ± 2.0 | |
| Electric voltage % of reading | ± 0.6 | |
| Notes: 1. Test Operating Tolerance is the maximum permissible range of any measurement. When expressed as a percentage, the maximum allowable variation is the specified percentage of the average value. 2. Test Condition Tolerance is the maximum permissible variation of the average value of the measurement from the specified test condition. | | |

4.2 Method of Test. The test procedure for walk-in cooler and freezer systems that have matched Unit Coolers and condensing units, and the procedures of testing condensing units and Unit Coolers individually for are described in Appendix C of this standard.

4.3 Test Conditions. Walk-in systems, condensing units and Unit Coolers shall be tested under the standard rating conditions defined in Section 5.

Section 5. Rating Requirements

5.1 Standard Ratings. Standard Ratings shall be established at the Standard Rating Conditions in the following listed tables and shall include its associated power input and Coefficient of Performance (COP). When tested with a specified motor, the associated compressor speed (external drive compressors only) shall also be included as part of the rating. The power required to operate all included accessories such as condenser fans, water pumps, controls, and similar accessories shall be accounted for in the power input and Coefficient of Performance. When external accessories such as water pumps, remote fans, and similar accessories are required for the operation of the unit but not included with the unit, the manufacturer shall clearly state that the rated power input and Coefficient of Performance do not account for additional power required by these external accessories. If a water-cooled condenser is used, the cooling water flow rate and pressure drop shall be specified as part of the rating. The condenser entering air wet bulb temperature only applies to evaporative condensers.

| Table 3. Fixed Capacity Matched Refrigerator System, Condensing Unit Located Indoor | | | | | | |
|---|---------------------------------------|---|-------------------------------------|-------------------------------------|---------------------------|---|
| Test Title | Unit Cooler Air Entering Dry-bulb, °C | Unit Cooler Air Entering Relative Humidity, % | Condenser Air Entering Dry-bulb, °C | Condenser Air Entering Wet-bulb, °C | Compressor Operating Mode | Test Objective |
| Off Cycle Fan Power | 2 | <50 | - | - | Compressor Off | Measure fan input wattage during compressor off cycle, $\dot{E}F_{comp,off}$ |
| Refrigeration Capacity | 2 | <50 | 32 | 24 ¹ | Compressor On | Determine Net Refrigeration Capacity of Unit Cooler, \dot{q}_{ss} , input power, \dot{E}_{ss} and COP at Rating condition |
| Note: 1. Required only for evaporative condensing units. | | | | | | |

| Table 4. Fixed Capacity Matched Refrigerator System, Condensing Unit Located Outdoor | | | | | | |
|--|---------------------------------------|---|-------------------------------------|---|---------------------------|---|
| Test Title | Unit Cooler Air Entering Dry-bulb, °C | Unit Cooler Air Entering Relative Humidity, % | Condenser Air Entering Dry-bulb, °C | Condenser Air Entering Wet-bulb ¹ , °C | Compressor Operating Mode | Test Objective |
| Off Cycle Fan Power | 2 | <50 | - | - | Compressor Off | Measure fan input wattage during compressor off cycle, $\dot{E}F_{comp,off}$ |
| Refrigeration Capacity A | 2 | <50 | 35 | 24 | Compressor On | Determine Net Refrigeration Capacity of Unit Cooler, $\dot{q}_{ss,A}^{k=1}$, input power, $\dot{E}_{ss,A}^{k=1}$, and COP at Rating Condition |

| Table 4. Fixed Capacity Matched Refrigerator System, Condensing Unit Located Outdoor (cont.) | | | | | | |
|--|---------------------------------------|---|-------------------------------------|-------------------------------------|---------------------------|--|
| Test Title | Unit Cooler Air Entering Dry-bulb, °C | Unit Cooler Air Entering Relative Humidity, % | Condenser Air Entering Dry-bulb, °C | Condenser Air Entering Wet-bulb, °C | Compressor Operating Mode | Test Objective |
| Refrigeration Capacity B | 2 | <50 | 15 | 12 | Compressor On | Determine Net Refrigeration Capacity of Unit Cooler, $\dot{q}_{SS,A}^{k=2}$, and system input power, $\dot{E}_{SS,A}^{k=2}$, at moderate condition |
| Refrigeration Capacity C | 2 | <50 | 2 | 1 | Compressor On | Determine Net Refrigeration Capacity of Unit Cooler, $\dot{q}_{SS,A}^{k=2}$, and system input power, $\dot{E}_{SS,A}^{k=2}$, at cold condition |
| Note: 1. Required only for evaporative condensing units. | | | | | | |

| Table 5. Two Capacity Matched Refrigerator System, Condensing Unit Located Outdoor | | | | | | |
|--|---------------------------------------|---|-------------------------------------|---|---------------------------|---|
| Test Title | Unit Cooler Air Entering Dry-bulb, °C | Unit Cooler Air Entering Relative Humidity, % | Condenser Air Entering Dry-bulb, °C | Condenser Air Entering Wet-bulb ¹ , °C | Compressor Operating Mode | Test Objective |
| Off Cycle Fan Power | 2 | <50 | - | - | Compressor Off | Measure fan input wattage during compressor off cycle, $\dot{E}F_{comp,off}$ |
| Refrigeration Capacity A Low Speed | 2 | <50 | 35 | 24 | Minimum Capacity | Determine Net Refrigeration Capacity of Unit Cooler, $\dot{q}_{SS,A}^{k=1}$, and input power, $\dot{E}_{SS,A}^{k=1}$, at Rating Condition and minimum compressor capacity |
| Refrigeration Capacity A High Speed | 2 | <50 | 35 | 24 | Maximum Capacity | Determine Net Refrigeration Capacity of Unit Cooler, $\dot{q}_{SS,A}^{k=2}$, input power, $\dot{E}_{SS,A}^{k=2}$, and COP at Rating Condition and maximum compressor capacity |

Table 5. Two Capacity Matched Refrigerator System, Condensing Unit Located Outdoor (cont.)

| Test Title | Unit Cooler Air Entering Dry-bulb, °C | Unit Cooler Air Entering Relative Humidity, % | Condenser Air Entering Dry-bulb, °C | Condenser Air Entering Wet-bulb ¹ , °C | Compressor Operating Mode | Test Objective |
|---|---------------------------------------|---|-------------------------------------|---|---------------------------|--|
| Refrigeration Capacity B Low Speed | 2 | <50 | 15 | 12 | Minimum Capacity | Determine Net Refrigeration Capacity of Unit Cooler, $\dot{q}_{ss,B}^{k=1}$, and system input power, $\dot{E}_{ss,B}^{k=1}$, at moderate condition and minimum compressor capacity |
| Refrigeration Capacity B High Speed | 2 | <50 | 15 | 12 | Maximum Capacity | Determine Net Refrigeration Capacity of Unit Cooler, $\dot{q}_{ss,B}^{k=2}$, and system input power, $\dot{E}_{ss,B}^{k=2}$, at moderate condition and maximum compressor capacity |
| Refrigeration Capacity C Low Speed | 2 | <50 | 2 | 1 | Minimum Capacity | Determine Net Refrigeration Capacity of Unit Cooler, $\dot{q}_{ss,C}^{k=1}$, and system input power, $\dot{E}_{ss,C}^{k=1}$, at cold condition and minimum compressor capacity |
| Refrigeration Capacity C High Speed | 2 | <50 | 2 | 1 | Maximum Capacity | Determine Net Refrigeration Capacity of Unit Cooler, $\dot{q}_{ss,C}^{k=2}$, and system input power, $\dot{E}_{ss,C}^{k=2}$ at cold condition and maximum compressor capacity |
| Note: 1. Required only for evaporative condensing units. | | | | | | |

| Table 6. Variable Capacity Matched Refrigerator System, Condensing Unit Located Outdoor | | | | | | |
|---|---------------------------------------|---|-------------------------------------|---|--|---|
| Test Title | Unit Cooler Air Entering Dry-bulb, °C | Unit Cooler Air Entering Relative Humidity, % | Condenser Air Entering Dry-bulb, °C | Condenser Air Entering Wet-bulb ² , °C | Compressor Operating Mode | Test Objective |
| Off Cycle Fan Power | 2 | <50 | - | - | Compressor Off | Measure fan input wattage during compressor off cycle, $\dot{E}F_{comp,off}$ |
| Refrigeration Capacity A Low Speed | 2 | <50 | 35 | 24 | Minimum Capacity, k = 1 | Determine Net Refrigeration Capacity of Unit Cooler, $\dot{q}_{ss,A}^{k=1}$, and system input power, $\dot{E}_{ss,A}^{k=1}$ at Rating Condition and minimum compressor capacity |
| Refrigeration Capacity A Variable Speed | 2 | <50 | 35 | 24 | Intermediate Capacity ¹ , k = i | Determine Net Refrigeration Capacity of Unit Cooler, $\dot{q}_{ss,A}^{k=i}$, and system input power, $\dot{E}_{ss,A}^{k=i}$, at Rating Condition and intermediate compressor capacity |
| Refrigeration Capacity A High Speed | 2 | <50 | 35 | 24 | Maximum Capacity, k = 2 | Determine Net Refrigeration Capacity of Unit Cooler, $\dot{q}_{ss,A}^{k=2}$, system input power, $\dot{E}_{ss,A}^{k=2}$, and COP at Rating Condition and maximum compressor capacity |
| Refrigeration Capacity B Low Speed | 2 | <50 | 15 | 12 | Minimum Capacity, k = 1 | Determine Net Refrigeration Capacity of Unit Cooler, $\dot{q}_{ss,B}^{k=1}$, and system input power, $\dot{E}_{ss,B}^{k=1}$ at moderate condition and minimum compressor capacity |
| Refrigeration Capacity B Variable Speed | 2 | <50 | 15 | 12 | Intermediate Capacity ¹ , k = i | Determine Net Refrigeration Capacity of Unit Cooler, $\dot{q}_{ss,B}^{k=i}$, and system input power, $\dot{E}_{ss,B}^{k=i}$, at moderate condition and intermediate compressor capacity |

Table 6. Variable Capacity Matched Refrigerator System, Condensing Unit Located Outdoor (cont.)

| Test Title | Unit Cooler Air Entering Dry-bulb, °C | Unit Cooler Air Entering Relative Humidity, % | Condenser Air Entering Dry-bulb, °C | Condenser Air Entering Wet-bulb ² , °C | Compressor Operating Mode | Test Objective |
|---|---------------------------------------|---|-------------------------------------|---|--|---|
| Refrigeration Capacity B High Speed | 2 | <50 | 15 | 12 | Maximum Capacity, k = 2 | Determine Net Refrigeration Capacity of Unit Cooler, $\dot{q}_{SS,B}^{k=i}$, and system input power, $\dot{E}_{SS,B}^{k=i}$, at moderate condition and maximum compressor capacity |
| Refrigeration Capacity C Low Speed | 2 | <50 | 2 | 1 | Minimum Capacity, k = 1 | Determine Net Refrigeration Capacity of Unit Cooler, $\dot{q}_{SS,B}^{k=i}$, and system input power, $\dot{E}_{SS,B}^{k=i}$, at cold condition and minimum compressor capacity |
| Refrigeration Capacity C Variable Speed | 2 | <50 | 2 | 1 | Intermediate Capacity ¹ , k = i | Determine Net Refrigeration Capacity of Unit Cooler, $\dot{q}_{SS,B}^{k=i}$, and system input power, $\dot{E}_{SS,B}^{k=i}$, at cold condition and intermediate compressor capacity |
| Refrigeration Capacity C High Speed | 2 | <50 | 2 | 1 | Maximum Capacity, k = 2 | Determine Net Refrigeration Capacity of Unit Cooler, $\dot{q}_{SS,B}^{k=i}$, and system input power, $\dot{E}_{SS,B}^{k=i}$, at cold condition and maximum compressor capacity |

Notes:

1. For the intermediate capacity test, the compressor capacity shall be set to 40% of its maximum capacity if possible. Otherwise, it shall be set to the capacity that is the closest to the 40% of its maximum capacity.
2. Required only for evaporative condensing units.

| Table 7. Fixed Capacity Matched Freezer System, Condensing Unit Located Indoor | | | | | | |
|--|---------------------------------------|---|-------------------------------------|---|---------------------------|--|
| Test Title | Unit Cooler Air Entering Dry-bulb, °C | Unit Cooler Air Entering Relative Humidity, % | Condenser Air Entering Dry-bulb, °C | Condenser Air Entering Wet-bulb ¹ , °C | Compressor Operating Mode | Test Objective |
| Off Cycle Fan Power | -23 | <50 | - | - | Compressor Off | Measure fan input wattage during compressor off cycle, $\dot{E}F_{comp,off}$ |
| Refrigeration Capacity | -23 | <50 | 32 | 24 | Compressor On | Determine Net Refrigeration Capacity of Unit Cooler, $\dot{q}_{ss,A}$, system input power, $\dot{E}_{ss,A}$, and COP at Rating Condition |
| Defrost Frost Load | -23 | Varying | 32 | 24 | System Dependent | Test according to Appendix C Section C11, $\dot{D}F$, \dot{Q}_{DF} . |
| Note: 1. Required only for evaporative condensing units. | | | | | | |

| Table 8. Fixed Capacity Matched Freezer System, Condensing Unit Located Outdoor | | | | | | |
|---|---------------------------------------|---|-------------------------------------|---|---------------------------|--|
| Test Title | Unit Cooler Air Entering Dry-Bulb, °C | Unit Cooler Air Entering Relative Humidity, % | Condenser Air Entering Dry-bulb, °C | Condenser Air Entering Wet-bulb ¹ , °C | Compressor Operating Mode | Test Objective |
| Off Cycle Fan Power | -23 | <50 | - | - | Compressor Off | Measure fan input wattage during compressor off cycle, $\dot{E}F_{comp,off}$ |
| Refrigeration Capacity A | -23 | <50 | 35 | 24 | Compressor On | Determine Net Refrigeration Capacity of Unit Cooler, $\dot{q}_{ss,A}$, system input power, $\dot{E}_{ss,A}$, and COP at Rating Condition |
| Refrigeration Capacity B | -23 | <50 | 15 | 12 | Compressor On | Determine Net Refrigeration Capacity of Unit Cooler, $\dot{q}_{ss,A}$, system input power, $\dot{E}_{ss,A}$, at moderate condition |

Table 8. Fixed Capacity Matched Freezer System, Condensing Unit Located Outdoor (cont.)

| Test Title | Unit Cooler Air Entering Dry-Bulb, °C | Unit Cooler Air Entering Relative Humidity, % | Condenser Air Entering Dry-bulb, °C | Condenser Air Entering Wet-bulb ¹ , °C | Compressor Operating Mode | Test Objective |
|--------------------------|---------------------------------------|---|-------------------------------------|---|---------------------------|--|
| Refrigeration Capacity C | -23 | <50 | 2 | 1 | Compressor On | Determine Net Refrigeration Capacity of Unit Cooler, $\dot{q}_{ss,A}$, system input power, $\dot{E}_{ss,A}$, at cold condition |
| Defrost Frost Load | -23 | Varying | 35 | 24 | System Dependent | Test according to Appendix C Section C11, $D\dot{F}$, \dot{Q}_{DF} . |

Note:

1. Required only for evaporative condensing units.

Table 9. Two Capacity Matched Freezer System, Condensing Unit Located Outdoor

| Test Title | Unit Cooler Air Entering Dry-Bulb, °C | Unit Cooler Air Entering Relative Humidity, % | Condenser Air Entering Dry-bulb, °C | Condenser Air Entering Wet-bulb ¹ , °C | Compressor Operating Mode | Test Objective |
|------------------------------------|---------------------------------------|---|-------------------------------------|---|---------------------------|--|
| Off Cycle Fan Power | -23 | <50 | - | - | Compressor Off | Measure fan input wattage during compressor off cycle, $\dot{E}F_{comp,off}$ |
| Refrigeration Capacity A Low Speed | -23 | <50 | 35 | 24 | Minimum Capacity | Determine Net Refrigeration Capacity of Unit Cooler, $\dot{q}_{ss,B}^{k=2}$, and system input power, $\dot{E}_{ss,B}^{k=2}$, at Rating Condition and minimum compressor capacity |

| Table 9. Two Capacity Matched Freezer System, Condensing Unit Located Outdoor (cont.) | | | | | | |
|---|---------------------------------------|---|-------------------------------------|---|---------------------------|--|
| Test Title | Unit Cooler Air Entering Dry-Bulb, °C | Unit Cooler Air Entering Relative Humidity, % | Condenser Air Entering Dry-bulb, °C | Condenser Air Entering Wet-bulb ¹ , °C | Compressor Operating Mode | Test Objective |
| Refrigeration Capacity A High Speed | -23 | <50 | 35 | 24 | Maximum Capacity | Determine Net Refrigeration Capacity of Unit Cooler, $q_{ss,B}^{k=2}$, and system input power, $E_{ss,B}^{k=2}$, and COP at Rating Condition and maximum compressor capacity |
| Refrigeration Capacity B Low Speed | -23 | <50 | 15 | 12 | Minimum Capacity | Determine Net Refrigeration Capacity of Unit Cooler, $q_{ss,B}^{k=2}$, and system input power, $E_{ss,B}^{k=2}$, at moderate condition and minimum compressor capacity |
| Refrigeration Capacity B High Speed | -23 | <50 | 15 | 12 | Maximum Capacity | Determine Net Refrigeration Capacity of Unit Cooler, $q_{ss,B}^{k=2}$, and system input power, $E_{ss,B}^{k=2}$, at moderate condition and maximum compressor capacity |
| Refrigeration Capacity C Low Speed | -23 | <50 | 2 | 1 | Minimum Capacity | Determine Net Refrigeration Capacity of Unit Cooler, $q_{ss,B}^{k=2}$, and system input power, $E_{ss,B}^{k=2}$, at cold condition and minimum compressor capacity |
| Refrigeration Capacity C High Speed | -23 | <50 | 2 | 1 | Maximum Capacity | Determine Net Refrigeration Capacity of Unit Cooler, $q_{ss,B}^{k=2}$, and system input power, $E_{ss,B}^{k=2}$, at cold condition and maximum compressor capacity |

Table 9. Two Capacity Matched Freezer System, Condensing Unit Located Outdoor (cont.)

| Test Title | Unit Cooler Air Entering Dry-Bulb, °C | Unit Cooler Air Entering Relative Humidity, % | Condenser Air Entering Dry-bulb, °C | Condenser Air Entering Wet-bulb ¹ , °C | Compressor Operating Mode | Test Objective |
|--------------------|---------------------------------------|---|-------------------------------------|---|---------------------------|---|
| Defrost Frost Load | -23 | Varying | 35 | 24 | System Dependent | Test according to Appendix C Section C11, DF , \dot{Q}_{DF} . |

Note:

1. Required only for evaporative condensing units.

| Table 10. Variable Capacity Matched Freezer System, Condensing Unit Located Outdoor | | | | | | |
|---|---------------------------------------|---|-------------------------------------|---|------------------------------------|--|
| Test Title | Unit Cooler Air Entering Dry-Bulb, °C | Unit Cooler Air Entering Relative Humidity, % | Condenser Air Entering Dry-bulb, °C | Condenser Air Entering Wet-bulb ² , °C | Compressor Operating Mode | Test Objective |
| Off Cycle Fan Power | -23 | <50 | - | - | Compressor Off | Measure fan input wattage during compressor off cycle, $\dot{E}F_{comp,off}$ |
| Refrigeration Capacity A Low Speed | -23 | <50 | 35 | 24 | Minimum Capacity | Determine Net Refrigeration Capacity of Unit Cooler, $\dot{q}_{ss,B}^{k=2}$ and system input power, $\dot{E}_{ss,B}^{k=2}$, at Rating Condition and minimum compressor capacity |
| Refrigeration Capacity A Variable Speed | -23 | <50 | 35 | 24 | Intermediate Capacity ¹ | Determine Net Refrigeration Capacity of Unit Cooler, $\dot{q}_{ss,B}^{k=2}$ and system input power, $\dot{E}_{ss,B}^{k=2}$, at Rating Condition and intermediate compressor capacity |
| Refrigeration Capacity A High Speed | -23 | <50 | 35 | 24 | Maximum Capacity | Determine Net Refrigeration Capacity of Unit Cooler, $\dot{q}_{ss,B}^{k=2}$ and system input power, $\dot{E}_{ss,B}^{k=2}$, and COP at Rating Condition and maximum compressor capacity |
| Refrigeration Capacity B Low Speed | -23 | <50 | 15 | 12 | Minimum Capacity | Determine Net Refrigeration Capacity of Unit Cooler, $\dot{q}_{ss,B}^{k=2}$ and system input power, $\dot{E}_{ss,B}^{k=2}$, at moderate condition and minimum compressor capacity |
| Refrigeration Capacity B Variable Speed | -23 | <50 | 15 | 12 | Intermediate Capacity ¹ | Determine Net Refrigeration Capacity of Unit Cooler, $\dot{q}_{ss,B}^{k=2}$ and system input power, $\dot{E}_{ss,B}^{k=2}$, at moderate condition and intermediate compressor capacity |

Table 10. Variable Capacity Matched Freezer System, Condensing Unit Located Outdoor (cont.)

| Test Title | Unit Cooler Air Entering Dry-Bulb, °C | Unit Cooler Air Entering Relative Humidity, % | Condenser Air Entering Dry-bulb, °C | Condenser Air Entering Wet-bulb ² , °C | Compressor Operating Mode | Test Objective |
|---|---------------------------------------|---|-------------------------------------|---|------------------------------------|---|
| Refrigeration Capacity B High Speed | -23 | <50 | 15 | 12 | Maximum Capacity | Determine Net Refrigeration Capacity of Unit Cooler, $\dot{q}_{SS,B}^{k=2}$ and system input power, $\dot{E}_{SS,B}^{k=2}$, at moderate condition and maximum compressor capacity |
| Refrigeration Capacity C Low Speed | -23 | <50 | 2 | 1 | Minimum Capacity | Determine Net Refrigeration Capacity of Unit Cooler, $\dot{q}_{SS,B}^{k=2}$ and system input power, $\dot{E}_{SS,B}^{k=2}$, at cold condition and minimum compressor capacity |
| Refrigeration Capacity C Variable Speed | -23 | <50 | 2 | 1 | Intermediate Capacity ¹ | Determine Net Refrigeration Capacity of Unit Cooler, $\dot{q}_{SS,B}^{k=2}$ and system input power, $\dot{E}_{SS,B}^{k=2}$, at cold condition and intermediate compressor capacity |
| Refrigeration Capacity C High Speed | -23 | <50 | 2 | 1 | Maximum Capacity | Determine Net Refrigeration Capacity of Unit Cooler, $\dot{q}_{SS,B}^{k=2}$ and system input power, $\dot{E}_{SS,B}^{k=2}$, at cold condition and maximum compressor capacity |
| Defrost Frost Load | -23 | Varying | 35 | 24 | System Dependent | Test according to Appendix C Section C11, \dot{D}_F , \dot{Q}_{DF} . |

Notes:

1. For the intermediate capacity test, the compressor capacity shall be set to 50% of its maximum capacity if possible. Otherwise, it shall be set to the capacity that is the closest to the 50% of its maximum capacity.
2. Required only for evaporative condensing units.

| Table 11. Fixed Capacity Refrigerator Condensing Unit, Condensing Unit Located Indoor ¹ | | | | | | |
|--|----------------------|------------------------------|-------------------------------------|---|---------------------------|---|
| Test Title | Suction Dewpoint, °C | Return Gas ² , °C | Condenser Air Entering Dry-bulb, °C | Condenser Air Entering Wet-bulb ³ , °C | Compressor Operating Mode | Test Objective |
| Refrigeration Capacity at compressor on | -5 | 5 | 32 | 24 | Compressor On | Determine Gross Refrigeration Capacity and input power of condensing unit at Rating Condition |
| Notes: | | | | | | |
| 1. Subcooling to be set according to equipment specification and reported as part of standard rating | | | | | | |
| 2. Measured at the condensing unit inlet location. | | | | | | |
| 3. Required only for evaporative condensing units | | | | | | |

| Table 12. Fixed Capacity Refrigerator Condensing Unit, Condensing Unit Located Outdoor ¹ | | | | | | |
|--|----------------------|------------------------------|-------------------------------------|---|---------------------------|---|
| Test Title | Suction Dewpoint, °C | Return Gas ² , °C | Condenser Air Entering Dry-bulb, °C | Condenser Air Entering Wet-bulb ³ , °C | Compressor Operating Mode | Test Objective |
| Refrigeration Capacity Ambient Condition A | -5 | 5 | 35 | 24 | Compressor On | Determine Gross Refrigeration Capacity, $\dot{Q}_{gross,i}$, and input power, $\dot{E}_{CU,on}$, of condensing unit at Rating Condition |
| Refrigeration Capacity Ambient Condition B | -5 | 5 | 15 | 12 | Compressor On | Determine Gross Refrigeration Capacity, $\dot{Q}_{gross,i}$, and input power, $\dot{E}_{CU,on}$, of condensing unit at moderate condition |
| Refrigeration Capacity Ambient Condition C | -5 | 5 | 2 | 1 | Compressor On | Determine Gross Refrigeration Capacity, $\dot{Q}_{gross,i}$, and input power, $\dot{E}_{CU,on}$, of condensing unit at cold condition |
| Notes: | | | | | | |
| 1. Subcooling shall be set according to equipment specification and reported as part of standard rating. | | | | | | |
| 2. Measured at the condensing unit inlet location. | | | | | | |
| 3. Required only for evaporative condensing units. | | | | | | |

Table 13. Fixed Capacity Freezer Condensing Unit, Condensing Unit Located Indoor¹

| Test Title | Suction Dewpoint, °C | Return Gas ² , °C | Condenser Air Entering Dry-bulb, °C | Condenser Air Entering Wet-bulb ³ , °C | Compressor Operating Mode | Test Objective |
|--------------------------------------|----------------------|------------------------------|-------------------------------------|---|---------------------------|---|
| Refrigeration Capacity Compressor On | -30 | -15 | 32 | 24 | Compressor On | Determine Gross Refrigeration Capacity, $\dot{Q}_{gross,i}$, and input power, $\dot{E}_{CU,on}$, of condensing unit at Rating Condition |

Notes:

1. Subcooling shall be set according to equipment specification and reported as part of standard rating.
2. Measured at the condensing unit inlet location.
3. Required only for evaporative condensing units.

Table 14. Fixed Capacity Freezer Condensing Unit, Condensing Unit Located Outdoor¹

| Test Title | Suction Dewpoint, °C | Return Gas ² , °C | Condenser Air Entering Dry-bulb, °C | Condenser Air Entering Wet-bulb ³ , °C | Compressor Operating Mode | Test Objective |
|--|----------------------|------------------------------|-------------------------------------|---|---------------------------|---|
| Refrigeration Capacity Ambient Condition A | -30 | -15 | 35 | 24 | Compressor On | Determine Gross Refrigeration Capacity, $\dot{Q}_{gross,A}$, and input power, $\dot{E}_{CU,on,A}$, of condensing unit at Rating Condition |
| Refrigeration Capacity Ambient Condition B | -30 | -15 | 15 | 12 | Compressor On | Determine Gross Refrigeration Capacity, $\dot{Q}_{gross,A}$, and input power, $\dot{E}_{CU,on,A}$, of condensing unit at moderate condition |
| Refrigeration Capacity Ambient Condition C | -30 | -15 | 2 | 1 | Compressor On | Determine Gross Refrigeration Capacity, $\dot{Q}_{gross,A}$, and input power, $\dot{E}_{CU,on,A}$, of condensing unit at cold condition |

Notes:

1. Subcooling shall be set according to equipment specification and reported as part of standard rating.
2. Measured at the condensing unit inlet location.
3. Required only for evaporative condensing units.

| Table 15. Refrigerator Unit Cooler ¹ | | | | | | | |
|--|---------------------------------------|---|-----------------------------|-------------------------------------|--------------------------------|---------------------------|--|
| Test Title | Unit Cooler Air Entering Dry-bulb, °C | Unit Cooler Air Entering Relative Humidity, % | Saturation Suction Temp, °C | Liquid Inlet Saturation Temperature | Liquid Inlet Subcooling, Deg K | Compressor Operating Mode | Test Objective |
| Off Cycle Fan Power | 2 | <50 | - | - | - | Compressor Off | Measure fan input power during compressor off cycle, $\dot{E}F_{comp,off}$ |
| Refrigeration Capacity | 2 | <50 | -4 | 41 | 5 | Compressor On | Determine Net Refrigeration Capacity of Unit Cooler, $\dot{q}_{mix,rack}$ |
| Note: 1. Superheat shall be set according to equipment specification in equipment or installation manual, if no superheat specification is given a default superheat value of 6.5°F shall be used. The superheat setting used in the test shall be reported as part of standard rating. | | | | | | | |

| Table 16. Freezer Unit Cooler ¹ | | | | | | | |
|--|---------------------------------------|---|-----------------------------|-------------------------------------|--------------------------------|---------------------------|--|
| Test Title | Unit Cooler Air Entering Dry-bulb, °C | Unit Cooler Air Entering Relative Humidity, % | Saturation Suction Temp, °C | Liquid Inlet Saturation Temperature | Liquid Inlet Subcooling, Deg K | Compressor Operating Mode | Test Objective |
| Off Cycle Fan Power | -23 | <50 | - | - | - | Compressor Off | Measure fan input wattage during compressor off cycle, $\dot{E}F_{comp,off}$ |
| Refrigeration Capacity | -23 | <50 | -29 | 41 | 5 | Compressor On | Determine Net Refrigeration Capacity of Unit Cooler, $\dot{q}_{mix,rack}$ |
| Defrost | -23 | Varying | - | - | - | Compressor Off | Test according to Appendix C Section C11, $\dot{D}F, \dot{Q}_{DF}$. |
| Note: 1. Superheat shall be set according to equipment specification in equipment or installation manual, if no superheat specification is given a default superheat value of 3.5°C shall be used. The superheat setting used in the test shall be reported as part of standard rating. | | | | | | | |

5.2 Application Ratings. Application Ratings shall consist of a Capacity Rating, the associated power input and the associated Coefficient of Performance (COP). When tested with a specified motor, the associated compressor speed (external drive compressors only), shall also be included as part of the rating. The power required to operate all included accessories such as condenser fans, water pumps, controls, and similar accessories shall be accounted for in the power input and Coefficient of Performance.

When external accessories such as water pumps, remote fans, and similar accessories are required for the operation of the unit but are not included with the unit, the manufacturer shall clearly state that the rated power input and Coefficient of Performance do not account for additional power required by these external accessories.

Application Ratings shall be reported at rated voltage, phase, and frequency.

5.3 Tolerances. To comply with this standard, measured test results shall not be less than 95% of Published Ratings for capacity and energy efficiency. Power input shall be no more than 105% of the rated values.

5.4 Electric Conditions. Standard Rating tests shall be performed at the nameplate rated voltage(s) and frequency. For air-cooled equipment which is rated with 208-230 V dual nameplate voltages, Standard Rating tests shall be performed at 230 V. For all other dual nameplate voltage equipment covered by this standard, the Standard Rating tests shall be performed at both voltages or at the lower of the two voltages if only a single Standard Rating is to be published.

Section 6. Calculation for Walk-in Box Load

6.1 General Description. The Walk-in Box Load is comprised of a High Load Period (BLH) of the day corresponding to frequent door openings, product loading events, and other design Load Factors, and a Low Load Period of the day (BLL) corresponding to the minimum load resulting from conduction, internal heat gains from equipment that is not related to the refrigeration system, and infiltration when the door is closed. Both the BLH and BLL are defined as a linear relationship with outdoor ambient temperature. This relationship accounts for the influence of outdoor ambient on the conduction and infiltration loads for a “typical” walk-in box. At the refrigeration system design point of 35°C for outdoor condensing unit/coil or 32°C for indoor condensing unit, the ratio of BLH to steady state refrigeration system capacity is 0.70 for refrigerators and 0.80 for freezers; the ratio of BLL to steady state refrigeration system capacity is 0.10 for refrigerators and 0.40 for freezers. The High Load Period for BLH is 8 hours per day, and the Low Load Period for BLL is 16 hours per day.

6.2 Refrigerator Load Equations

6.2.1 Indoor Condensing Unit. The walk-in box and the condensing unit are both located within a conditioned space. The Walk-in Box Load during a High Load Period is calculated by

$$BLH = 0.7 \cdot \dot{q}_{ss,ID} \quad 1$$

In which, the box load equals to 70% of the refrigeration system steady state net capacity at the design point of 32°C. The Net Refrigeration Capacity is to be measured directly from the test by following the procedure defined in the Section 4 of this standard.

The box load during a Low Load Period equals to 10% of the refrigeration system steady state net capacity at the design point of 32°C, and can be calculated by

$$BLL = 0.1 \cdot \dot{q}_{ss,ID} \quad 2$$

6.2.2 Outdoor Condensing Unit. The Walk-in Box Load at different bin temperatures (t_j) during High and Low Load Periods are calculated by

$$BLH(t_j) = 0.65 \cdot \dot{q}_{ss,A} + 0.05 \cdot \frac{\dot{q}_{ss,A} \cdot (t_j - 2)}{33} \quad 3$$

$$BLL(t_j) = 0.03 \cdot \dot{q}_{ss,A} + 0.07 \cdot \frac{\dot{q}_{ss,A} \cdot (t_j - 2)}{33} \quad 4$$

6.3 Freezer Load Equations.

6.3.1 Indoor Condensing Unit. The walk-in box and the condensing unit are both located within a conditioned space. The Walk-in Box Load during a High Load Period is calculated as.

$$BLH = 0.8 \cdot \dot{q}_{ss,ID} \quad 5$$

In which, the box load equals to 80% of the refrigeration system steady state net capacity at the design point of 32°C. The Net Refrigeration Capacity is to be measured directly from the test by following the procedure defined in the Section 4 of this standard.

The box load during a Low Load Period equals to 40% of the refrigeration system steady state net capacity at the design point of 32°C, and can be calculated by,

$$BLL = 0.4 \cdot \dot{q}_{ss,ID} \quad 6$$

6.3.2 Outdoor Condensing Unit. The Walk-in Box Load during High and Low Load Periods are calculated by

$$BLH(t_j) = 0.55 \cdot \dot{q}_{ss,A} + 0.25 \cdot \frac{\dot{q}_{ss,A} \cdot (t_j + 23)}{58} \quad 7$$

$$BLL(t_j) = 0.15 \cdot \dot{q}_{ss,A} + 0.25 \cdot \frac{\dot{q}_{ss,A} \cdot (t_j + 23)}{58} \quad 8$$

Section 7. Calculation for Annual Walk-in Energy Factor

7.1 General Description. The calculation procedure described in this section is based on the data performance obtained from the tests under the standard Rating Conditions defined in Section 5 for single-capacity, two-capacity and variable capacity systems. The calculation method depends on outlining system capacity and power profiles over different temperature bins using laboratory test results. The Annual Walk-in Energy Factor, AWEF, is calculated by weighting system performance at individual bins with bin hours (number of hours for a given temperature occurs over the year), that is defined in Appendix D.

7.2 The Total Walk-in System Heat Load include the Walk-in Box Load (BLH and BLL), defined in Section 6, and the heat load contributed by the operation of the refrigeration system (i.e. evaporator fan power and defrost). The Total Walk-in System Heat Load is also comprised of a High Load Period (WLH) and a Low Load Period (WLL), corresponding to the Walk-in Box Loads BLH and BLL. The refrigeration system operates 1/3 of operating hours under High Load Period, and 2/3 of operating time during Low Load Period as defined in Section 6.1.

7.3 Load Factor is defined as the ratio of the Total Walk-in System Heat Load to the system Net Refrigeration Capacity. The Load Factors during high and Low Load Periods at each bin temperature can be calculated by

$$LFH(t_j) = \frac{WLH(t_j)}{\dot{q}_{ss}(t_j)} \quad 9$$

$$LFL(t_j) = \frac{WLL(t_j)}{\dot{q}_{ss}(t_j)} \quad 10$$

7.4 Walk-in Unit with Single Capacity Compressor.

7.4.1 The operation of units with single capacity compressors is illustrated in Figure 7-1. The Total Walk-in System Heat Loads at each bin temperature during high and Low Load Periods for the walk-in unit with single capacity compressor are calculated by the following equations. The terms of defrost power contributing to the box load, \dot{Q}_{DF} , and to the system power consumption, DF, in these equations shall only be applied to the walk-in freezer systems, and shall be set to zero during the calculation for the walk-in refrigerator systems.

$$W\dot{L}H(t_j) = B\dot{L}H(t_j) + \dot{E}F_{\text{comp,off}} (1 - LFH(t_j)) + \dot{Q}_{DF} \quad 11$$

$$W\dot{L}L(t_j) = B\dot{L}L(t_j) + \dot{E}F_{\text{comp,off}} (1 - LFL(t_j)) + \dot{Q}_{DF} \quad 12$$

Where

$$LFH(t_j) = \frac{W\dot{L}H(t_j)}{\dot{q}_{ss}(t_j)} = \frac{B\dot{L}H(t_j) + \dot{E}F_{\text{comp,off}} + \dot{Q}_{DF}}{\dot{q}_{ss}(t_j) + \dot{E}F_{\text{comp,off}}} \quad 13$$

$$LFL(t_j) = \frac{W\dot{L}L(t_j)}{\dot{q}_{ss}(t_j)} = \frac{B\dot{L}L(t_j) + \dot{E}F_{\text{comp,off}} + \dot{Q}_{DF}}{\dot{q}_{ss}(t_j) + \dot{E}F_{\text{comp,off}}} \quad 14$$

The Annual Walk-in Energy Factor, AWEF, is determined by

$$AWEF = \sum_{j=1}^n BL(t_j) / \sum_{j=1}^n E(t_j) \quad 15$$

The term $BL(t_j)$ and $E(t_j)$, summed over temperature bins, are evaluated at each temperature bin, and calculated by

$$BL(t_j) = [0.33 \cdot B\dot{L}H(t_j) + 0.67 \cdot B\dot{L}L(t_j)] \cdot n_j \quad 16$$

$$E(t_j) = \left\{ \begin{array}{l} 0.33 \cdot [\dot{E}_{ss}(t_j) \cdot LFH(t_j) + \dot{E}F_{\text{comp,off}} (1 - LFH(t_j))] + 0.67 \cdot \\ [\dot{E}_{ss}(t_j) \cdot LFL(t_j) + \dot{E}F_{\text{comp,off}} (1 - LFL(t_j))] + \dot{D}F \end{array} \right\} \cdot n_j \quad 17$$

In the calculation above, the refrigeration system operates 1/3 of operating hours under High Load Period, and 2/3 of operating time during Low Load Period as defined in Section 7.2.

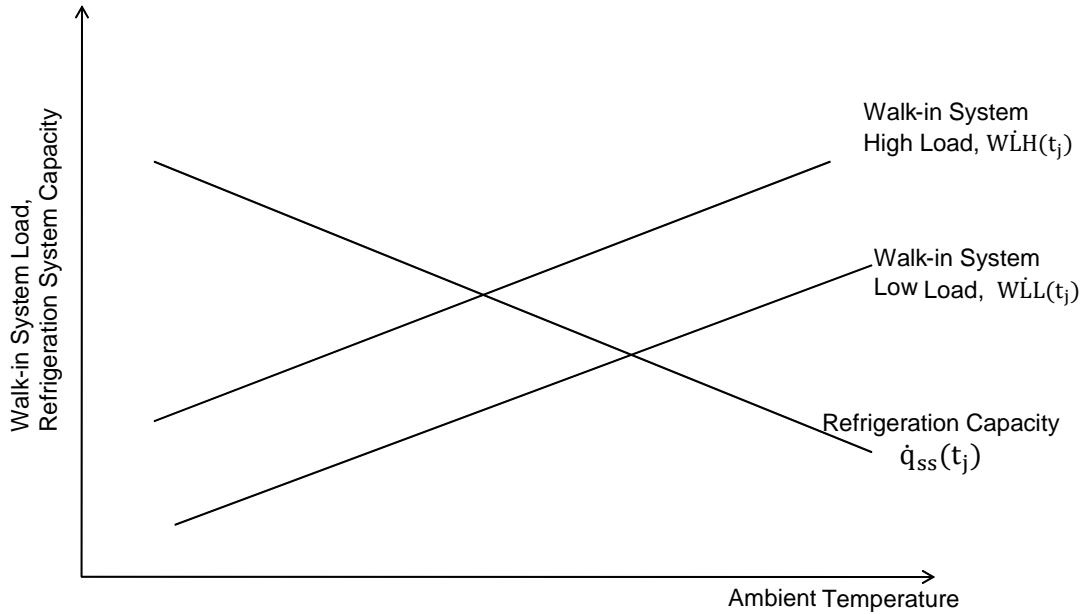

Figure 1. Schematic of the Operation for Units with Single Capacity Compressor

7.4.2 The system steady state Net Refrigeration Capacity and power consumption at a specific temperature bin shall use the measured values directly from the steady state tests if the bin temperature coincides with the designated rating conditions. When a bin temperature does not coincide with the designated rating condition, use the follow equations to calculate the net capacity and the power consumption.

If $t_j \leq 15$

$$\dot{q}_{ss}(t_j) = \dot{q}_{ss,C} + \frac{(\dot{q}_{ss,B} - \dot{q}_{ss,C})}{t_B - t_C} (t_j - t_C) \quad 18$$

$$\dot{E}_{ss}(t_j) = \dot{E}_{ss,C} + \frac{(\dot{E}_{ss,B} - \dot{E}_{ss,C})}{t_B - t_C} (t_j - t_C) \quad 19$$

If $t_j > 15$

$$\dot{q}_{ss}(t_j) = \dot{q}_{ss,B} + \frac{(\dot{q}_{ss,A} - \dot{q}_{ss,B})}{t_A - t_B} (t_j - t_B) \quad 20$$

$$\dot{E}_{ss}(t_j) = \dot{E}_{ss,B} + \frac{(\dot{E}_{ss,A} - \dot{E}_{ss,B})}{t_A - t_B} (t_j - t_B) \quad 21$$

7.5 Walk-in Unit with Two-Capacity Compressor

7.5.1 Two-capacity compressor means a walk-in unit that has one of the following:

- (1) A two-speed compressor
- (2) Two compressors where only one compressor ever operates at a time
- (3) Two compressors where one compressor (Compressor #1) operates at low loads and both compressors (Compressors #1 and #2) operate at high loads but Compressor #2 never operates alone, or
- (4) A compressor that is capable of cylinder or scroll unloading

For such systems, low capacity means:

- (1) Operating at low compressor speed
- (2) Operating the lower capacity compressor
- (3) Operating Compressor #1, or
- (4) Operating with the compressor unloaded (*e.g.*, operating one piston of a two-piston reciprocating compressor, using a fixed fractional volume of the full scroll, etc.)

For such systems, high capacity means:

- (1) Operating at high compressor speed
- (2) Operating the higher capacity compressor
- (3) Operating Compressors #1 and #2, or
- (4) Operating with the compressor loaded (*e.g.*, operating both pistons of a two-piston reciprocating compressor, using the full volume of the scroll)

The unit shall be tested at the designated test conditions for both high and low capacities to evaluate the steady state capacities and power consumptions.

7.5.2 For two-capacity compressor units, the Annual Walk-in Energy Factor, AWEF, is calculated by

$$AWEF = \sum_{j=1}^n BL(t_j) / \sum_{j=1}^n E(t_j) \quad 22$$

The term $BL(t_j)$ and $E(t_j)$, summed over temperature bins, are evaluated at each temperature bin according to four possible cases shown in Figure 7-2 and described as follows. These four cases can be identified in terms of three outdoor temperatures, t_H , t_{IL} and t_{IH} , which are also shown in Figure 7-2. The outdoor temperature t_{IH} is the temperature at which the Total Walk-in System Heat Load equals system net capacity when the compressor operates at low capacity ($k = 1$) during the High Load Period. The outdoor temperature t_{IL} is the temperature at which the Total Walk-in System

Heat Load equals system net capacity when the compressor operates at low capacity ($k = 1$) during the Low Load Period. The outdoor temperature t_{IIH} is the temperature at which the Total Walk-in System Heat Load equals system net capacity when the compressor operates at high capacity ($k = 2$) during the High Load Period.

The system steady state Net Refrigeration Capacity and power consumption at a specific temperature bin shall use the measured values directly from the steady state tests if the bin temperature coincides with the designated rating conditions, otherwise use the following equations to calculate the net capacities and the power consumptions for low capacity operation. For high capacity operation, use the same equations, but replace the superscript $k = 1$ by $k = 2$.

If $t_j \leq 15$

$$\dot{q}_{ss}^{k=1}(t_j) = \dot{q}_{ss,C}^{k=1} + \frac{(\dot{q}_{ss,B}^{k=1} - \dot{q}_{ss,C}^{k=1})}{t_B - t_C} (t_j - t_C) \tag{23}$$

$$\dot{E}_{ss}^{k=1}(t_j) = \dot{E}_{ss,C}^{k=1} + \frac{(\dot{E}_{ss,B}^{k=1} - \dot{E}_{ss,C}^{k=1})}{t_B - t_C} (t_j - t_C) \tag{24}$$

If $t_j > 15$

$$\dot{q}_{ss}^{k=1}(t_j) = \dot{q}_{ss,B}^{k=1} + \frac{(\dot{q}_{ss,A}^{k=1} - \dot{q}_{ss,B}^{k=1})}{t_A - t_B} (t_j - t_B) \tag{25}$$

$$\dot{E}_{ss}^{k=1}(t_j) = \dot{E}_{ss,B}^{k=1} + \frac{(\dot{E}_{ss,A}^{k=1} - \dot{E}_{ss,B}^{k=1})}{t_A - t_B} (t_j - t_B) \tag{26}$$

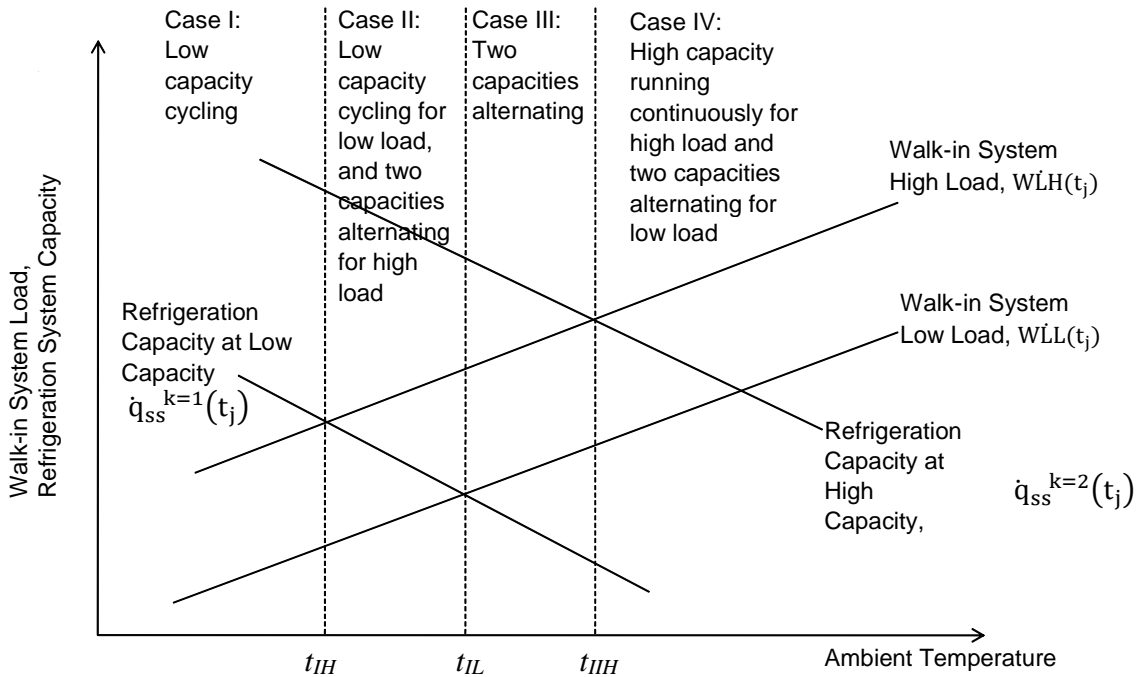

Figure 2. Schematic of the Various Modes of Operation for Units with Two Capacity or Two-stage Compressors

7.5.2.1 Case I. Low Capacity Cycling During Both Low and High Load Periods ($t_j < t_{IH}$). Units operate only at low compressor capacity, and cycle on and off to meet the Total Walk-in System Heat Load during both low and High Load Periods. In this case, units operate identically to single capacity units. The calculation of terms $BL(t_j)$ and $E(t_j)$ shall follow the single capacity compressor procedure described in Section 7.4.

7.5.2.2 Case II. Low Capacity Cycling During Low Load Period and Two Capacities Alternating During high Load Period ($t_{IH} < t_j < t_{IL}$). During a Low Load Period, units operate at low compressor capacity, and cycle on and off to meet the total walk-in system load. During a High Load Period, units alternate between high ($k = 2$) and low ($k = 1$) compressor capacities to satisfy the Total Walk-in System Heat Load at temperature t_j . In such a case, the compressor operates continuously during High Load Period. The terms of defrost power contributing to the box load, \dot{Q}_{DF} , and to the system power consumption, DF , in these equations shall only be applied to the walk-in freezer systems, and shall be set to zero during the calculation for the walk-in refrigerator systems.

$$W\dot{L}H(t_j) = B\dot{L}H(t_j) + \dot{Q}_{DF} \quad 27$$

$$W\dot{L}L(t_j) = B\dot{L}L(t_j) + \dot{E}F_{\text{comp,off}} (1 - LFL^{k=1}(t_j)) + \dot{Q}_{DF} \quad 28$$

$$LFH^{k=1}(t_j) = \frac{\dot{q}_{ss}^{k=2}(t_j) - W\dot{L}H(t_j)}{\dot{q}_{ss}^{k=2}(t_j) - \dot{q}_{ss}^{k=1}(t_j)} \quad 29$$

$$LFH^{k=2}(t_j) = 1 - LFH^{k=1}(t_j) \quad 30$$

$$LFL^{k=1}(t_j) = \frac{W\dot{L}L(t_j)}{\dot{q}_{ss}^{k=1}(t_j)} = \frac{B\dot{L}L(t_j) + \dot{E}F_{\text{comp,off}} + \dot{Q}_{DF}}{\dot{q}_{ss}^{k=1}(t_j) + \dot{E}F_{\text{comp,off}}} \quad 31$$

$$BL(t_j) = [0.33 \cdot B\dot{L}H(t_j) + 0.67 \cdot B\dot{L}L(t_j)] \cdot n_j \quad 32$$

$$E(t_j) = \left\{ \begin{array}{l} 0.33 \cdot \left(\dot{E}_{ss}^{k=2}(t_j) \cdot LFH^{k=2}(t_j) + \dot{E}_{ss}^{k=1} \cdot LFH^{k=1}(t_j) \right) + 0.67 \cdot \\ \left[\dot{E}_{ss}^{k=1}(t_j) \cdot LFL^{k=1}(t_j) + \dot{E}F_{\text{comp,off}} (1 - LFL^{k=1}(t_j)) \right] + DF \end{array} \right\} \cdot n_j \quad 33$$

7.5.2.3 Case III. Two Capacities Alternating During Both Low and High Load Periods ($t_{IL} < t_j < t_{IHH}$). Units alternate between high ($k = 2$) and low ($k = 1$) compressor capacities to satisfy the total walk-in system load at temperature t_j . In such a case, the compressor operates continuously. The terms of defrost power contributing to the box load, \dot{Q}_{DF} , and to the system power consumption, DF , in these equations shall only be applied to the walk-in freezer systems, and shall be set to zero during the calculation for the walk-in refrigerator systems.

$$W\dot{L}H(t_j) = B\dot{L}H(t_j) + \dot{Q}_{DF} \quad 34$$

$$W\dot{L}L(t_j) = B\dot{L}L(t_j) + \dot{Q}_{DF} \quad 35$$

$$LFH^{k=1}(t_j) = \frac{\dot{q}_{ss}^{k=2}(t_j) - W\dot{L}H(t_j)}{\dot{q}_{ss}^{k=2}(t_j) - \dot{q}_{ss}^{k=1}(t_j)} \quad 36$$

$$LFH^{k=2}(t_j) = 1 - LFH^{k=1}(t_j) \quad 37$$

$$LFL^{k=1}(t_j) = \frac{\dot{q}_{ss}^{k=2}(t_j) - W\dot{L}L(t_j)}{\dot{q}_{ss}^{k=2}(t_j) - \dot{q}_{ss}^{k=1}(t_j)} \quad 38$$

$$LFL^{k=2}(t_j) = 1 - LFL^{k=1}(t_j) \quad 39$$

$$BL(t_j) = [0.33 \cdot B\dot{L}H(t_j) + 0.67 \cdot B\dot{L}L(t_j)] \cdot n_j \quad 40$$

$$E(t_j) = [0.33 \cdot (\dot{E}_{ss}^{k=2}(t_j) \cdot LFH^{k=2}(t_j) + \dot{E}_{ss}^{k=1}(t_j) \cdot LFH^{k=1}(t_j)) + 0.67 \cdot (\dot{E}_{ss}^{k=2}(t_j) \cdot LFL^{k=2}(t_j) + \dot{E}_{ss}^{k=1}(t_j) \cdot LFL^{k=1}(t_j)) + \dot{D}F] \cdot n_j \quad 41$$

7.5.2.4 Case IV. High Capacity Running Continuously During High Load Period and Two Capacities Alternating During Low Load Period ($t_{IHH} < t_j$). During a Low Load Period, units alternate between high ($k = 2$) and low ($k = 1$) compressor capacities to satisfy the total walk-in system load at temperature t_j . During a High Load Period, units operate at high ($k = 2$) compressor capacity continuously. The terms of defrost power contributing to the box load, \dot{Q}_{DF} , and to the system power consumption, $\dot{D}F$, in these equations shall only be applied to the walk-in freezer systems, and shall be set to zero during the calculation for the walk-in refrigerator systems.

$$WLH(t_j) = BLH(t_j) + \dot{Q}_{DF} \quad 42$$

$$WLL(t_j) = BLL(t_j) + \dot{Q}_{DF} \quad 43$$

$$LFH^{k=2}(t_j) = 1 \quad 44$$

$$LFL^{k=1}(t_j) = \frac{\dot{q}_{ss}^{k=2}(t_j) - WLL(t_j)}{\dot{q}_{ss}^{k=2}(t_j) - \dot{q}_{ss}^{k=1}(t_j)} \quad 45$$

$$LFL^{k=2}(t_j) = 1 - LFL^{k=1}(t_j) \quad 46$$

$$BL(t_j) = [0.33 \cdot BLH(t_j) + 0.67 \cdot BLL(t_j)] \cdot n_j \quad 47$$

$$E(t_j) = \left[\begin{array}{c} 0.33 \cdot \dot{E}_{ss}^{k=2}(t_j) \cdot LFH^{k=2}(t_j) + 0.67 \cdot \\ (\dot{E}_{ss}^{k=2}(t_j) \cdot LFL^{k=2}(t_j) + \dot{E}_{ss}^{k=1}(t_j) \cdot LFL^{k=1}(t_j)) + \dot{D}F \end{array} \right] \cdot n_j \quad 48$$

7.6 Walk-in Unit with Variable Capacity Compressor.

7.6.1 The Annual Walk-in Energy Factor, AWEF, for the walk-in units with variable capacity compressors is determined by:

$$AWEF = \sum_{j=1}^n BL(t_j) / \sum_{j=1}^n E(t_j) \quad 49$$

The term $BL(t_j)$ and $E(t_j)$, summed over temperature bins, are evaluated at each temperature bin according to four possible cases shown in Figure 7-3 and described as follows. These four cases can be identified in terms of three outdoor temperatures, t_{IH} , t_{IL} and t_{IHH} , which are also shown in Figure 7-3. The outdoor temperature t_{IH} is the temperature at which the Total Walk-in System Heat Load equals system net capacity when the compressor operates at its minimum capacity ($k = 1$) during the High Load Period. The outdoor temperature t_{IL} is the temperature at which the Total Walk-in System Heat Load equals system net capacity when the compressor operates at its minimum capacity ($k = 1$) during the Low Load Period. The outdoor temperature t_{IHH} is the temperature at which the Total Walk-in System Heat Load equals system net capacity when the compressor operates at its maximum capacity ($k = 2$) during the High Load Period.

The system steady state Net Refrigeration Capacity and power consumption at a specific temperature bin shall use the measured values directly from the steady state tests if the bin temperature coincides with the designated rating conditions, otherwise use the following equations to calculate the net capacities and the power consumptions for minimum capacity operation. For intermediate and maximum capacities operation, use the same equations, but replace the superscript $k = 1$ by $k = i$ and $k = 2$, respectively.

If $t_j \leq 15$

$$\dot{q}_{ss}^{k=1}(t_j) = \dot{q}_{ss,C}^{k=1} + \frac{(\dot{q}_{ss,B}^{k=1} - \dot{q}_{ss,C}^{k=1})}{t_B - t_C} (t_j - t_C) \tag{50}$$

$$\dot{E}_{ss}^{k=1}(t_j) = \dot{E}_{ss,C}^{k=1} + \frac{(\dot{E}_{ss,C}^{k=1} - \dot{E}_{ss,C}^{k=1})}{t_B - t_C} (t_j - t_C) \tag{51}$$

If $t_j > 15$

$$\dot{q}_{ss}^{k=1}(t_j) = \dot{q}_{ss,B}^{k=1} + \frac{(\dot{q}_{ss,A}^{k=1} - \dot{q}_{ss,B}^{k=1})}{t_A - t_B} (t_j - t_B) \tag{52}$$

$$\dot{E}_{ss}^{k=1}(t_j) = \dot{E}_{ss,B}^{k=1} + \frac{(\dot{E}_{ss,A}^{k=1} - \dot{E}_{ss,B}^{k=1})}{t_A - t_B} (t_j - t_B) \tag{53}$$

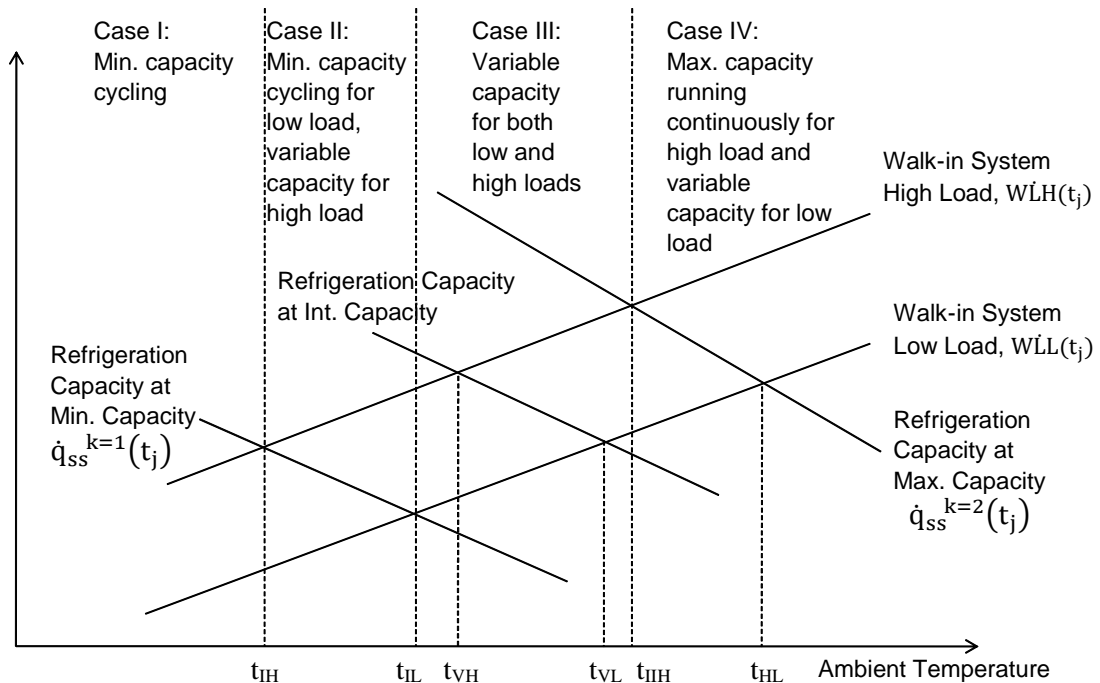

Figure 3. Schematic of the Various Modes of Operation for Units with Variable Speed Compressors

7.6.1.1 Case I. Minimum Capacity Cycling During Both Low and High Load Periods ($t_j < t_{IH}$). Units operate at the minimum capacity, and cycle on and off to meet the total walk-in system load during both low and High Load Periods. The terms of defrost power contributing to the box load, \dot{Q}_{DF} , and to the system power consumption, DF, in these equations shall only be applied to the walk-in freezer systems, and shall be set to zero during the calculation for the walk-in refrigerator systems.

$$\dot{W}LH(t_j) = \dot{B}LH(t_j) + \dot{E}F_{\text{comp,off}} (1 - LFH(t_j)) + \dot{Q}_{DF} \quad 54$$

$$\dot{W}LL(t_j) = \dot{B}LL(t_j) + \dot{E}F_{\text{comp,off}} (1 - LFL(t_j)) + \dot{Q}_{DF} \quad 55$$

$$LFH(t_j) = \frac{\dot{W}LH(t_j)}{\dot{q}_{ss}^{k=1}(t_j)} = \frac{\dot{B}LH(t_j) + \dot{E}F_{\text{comp,off}} + \dot{Q}_{DF}}{\dot{q}_{ss}^{k=1}(t_j) + \dot{E}F_{\text{comp,off}}} \quad 56$$

$$LFL(t_j) = \frac{\dot{W}LL(t_j)}{\dot{q}_{ss}^{k=1}(t_j)} = \frac{\dot{B}LL(t_j) + \dot{E}F_{\text{comp,off}} + \dot{Q}_{DF}}{\dot{q}_{ss}^{k=1}(t_j) + \dot{E}F_{\text{comp,off}}} \quad 57$$

$$BL(t_j) = [0.33 \cdot \dot{B}LH(t_j) + 0.67 \cdot \dot{B}LL(t_j)] \cdot \eta_j \quad 58$$

$$E(t_j) = \left\{ \begin{array}{l} 0.33 \cdot [\dot{E}_{ss}^{k=1}(t_j) \cdot LFH(t_j) + \dot{E}F_{\text{comp,off}} (1 - LFH(t_j))] + 0.67 \cdot \\ [\dot{E}_{ss}^{k=1}(t_j) \cdot LFL(t_j) + \dot{E}F_{\text{comp,off}} (1 - LFL(t_j))] + \dot{D}F \end{array} \right\} \cdot \eta_j \quad 59$$

7.6.1.2 Case II. Minimum Capacity Cycling During Low Load Period and Intermediate Capacity Operating Continuously During High Load Period ($t_{IH} < t_j < t_{IL}$). During a Low Load Period, units operate at minimum capacity, and cycle on and off to meet the total walk-in system load. During a high-load period, units operate at variable capacity ($k = v$). In such a case, the compressor varies the capacity between its minimum and maximum capacities, and continuously operates to match the total walk-in system load at temperature t_j . The terms of defrost power contributing to the box load, \dot{Q}_{DF} , and to the system power consumption, $\dot{D}F$, in these equations shall only be applied to the walk-in freezer systems, and shall be set to zero during the calculation for the walk-in refrigerator systems.

$$\dot{W}LL(t_j) = \dot{B}LL(t_j) + \dot{E}F_{\text{comp,off}} (1 - LFL^{k=1}(t_j)) + \dot{Q}_{DF} \quad 60$$

$$\dot{W}LH(t_j) = \dot{B}LH(t_j) + \dot{Q}_{DF} \quad 61$$

$$LFL^{k=1}(t_j) = \frac{\dot{B}LL(t_j) + \dot{E}F_{\text{comp,off}} + \dot{Q}_{DF}}{\dot{q}_{ss}^{k=1}(t_j) + \dot{E}F_{\text{comp,off}}} \quad 62$$

$$\dot{q}_{SS,H}^{k=v}(t_j) = \dot{W}LH(t_j) \quad 63$$

$$\dot{E}_{SS,H}^{k=v}(t_j) = \frac{\dot{q}_{SS,H}^{k=v}(t_j)}{COP_{SS,H}^{k=v}(t_j)} \quad 64$$

$$COP_{SS,H}^{k=v}(t_j) = a + b \cdot t_j + c \cdot t_j^2 \quad 65$$

To determine the coefficients a , b and c , it is required to evaluate the unit COP at three different compressor capacities: the minimum capacity ($k = 1$), the maximum capacity ($k = 2$), and the capacity ($k = i$) at which the intermediate-capacity test was conducted. The following is a procedure for evaluation of the coefficients a , b and c .

$$a = COP_{SS}^{k=2}(t_{IH}) - b \cdot t_{IH} - c \cdot t_{IH}^2 \quad 66$$

$$b = \frac{COP_{SS}^{k=1}(t_{IH}) - COP_{SS}^{k=2}(t_{IH}) - d \cdot [COP_{SS}^{k=1}(t_{IH}) - COP_{SS}^{k=i}(t_{VH})]}{t_{IH} - t_{IH} - d \cdot [t_{IH} - t_{IH}]} \quad 67$$

$$c = \frac{\text{COP}_{\text{SS}}^{k=1}(t_{\text{IH}}) - \text{COP}_{\text{SS}}^{k=2}(t_{\text{IHH}}) - b \cdot (t_{\text{IH}} - t_{\text{IHH}})}{t_{\text{IH}}^2 - t_{\text{IHH}}^2} \quad 68$$

$$d = \frac{t_{\text{IHH}}^2 - t_{\text{IH}}^2}{t_{\text{VH}}^2 - t_{\text{IH}}^2} \quad 69$$

Where:

$$\text{COP}_{\text{SS}}^{k=1}(t_{\text{IH}}) = \frac{\dot{q}_{\text{SS}}^{k=1}(t_{\text{IH}})}{\dot{E}_{\text{SS}}^{k=1}(t_{\text{IH}})} \quad 70$$

$$\text{COP}_{\text{SS}}^{k=2}(t_{\text{IHH}}) = \frac{\dot{q}_{\text{SS}}^{k=2}(t_{\text{IHH}})}{\dot{E}_{\text{SS}}^{k=2}(t_{\text{IHH}})} \quad 71$$

$$\text{COP}_{\text{SS}}^{k=i}(t_{\text{VH}}) = \frac{\dot{q}_{\text{SS}}^{k=i}(t_{\text{VH}})}{\dot{E}_{\text{SS}}^{k=i}(t_{\text{VH}})} \quad 72$$

The outdoor temperature t_{VH} is the temperature at which the Total Walk-in System Heat Load equals system net capacity when the compressor operates at its intermediate capacity ($k = i$) during the High Load Period.

$$\text{BL}(t_j) = [0.33 \cdot \text{BLH}(t_j) + 0.67 \cdot \text{BLL}(t_j)] \cdot n_j \quad 73$$

$$\text{E}(t_j) = \{0.33 \cdot \dot{E}_{\text{SS,H}}^{k=v}(t_j) + 0.67 \cdot [\dot{E}_{\text{SS}}^{k=1}(t_j) \cdot \text{LFL}^{k=1}(t_j) + \text{EF}_{\text{comp,off}}(1 - \text{LFL}^{k=1}(t_j))]\} + \text{DF} \cdot n_j \quad 74$$

7.6.1.3 Case III. Intermediate Capacity Running Continuously During Both Low and High Load Periods ($t_{\text{IL}} < t_j < t_{\text{IHH}}$). Units operate at variable compressor capacities ($k = v$) during both low and High Load Periods. The compressor varies the capacity between its minimum and maximum capacities, and continuously operate to match the total walk-in system load at temperature t_j . The terms of defrost power contributing to the box load, \dot{Q}_{DF} , and to the system power consumption, DF , in these equations shall only be applied to the walk-in freezer systems, and shall be set to zero during the calculation for the walk-in refrigerator systems.

$$\text{WLH}(t_j) = \text{BLH}(t_j) + \dot{Q}_{\text{DF}} \quad 75$$

$$\text{WLL}(t_j) = \text{BLL}(t_j) + \dot{Q}_{\text{DF}} \quad 76$$

$$\dot{q}_{\text{SS,H}}^{k=v}(t_j) = \text{WLH}(t_j) \quad 77$$

$$\dot{q}_{\text{SS,L}}^{k=v}(t_j) = \text{WLL}(t_j) \quad 78$$

$$\dot{E}_{\text{SS,H}}^{k=v}(t_j) = \frac{\dot{q}_{\text{SS,H}}^{k=v}(t_j)}{\text{COP}_{\text{SS,H}}^{k=v}(t_j)} \quad 79$$

$$\dot{E}_{\text{SS,L}}^{k=v}(t_j) = \frac{\dot{q}_{\text{SS,L}}^{k=v}(t_j)}{\text{COP}_{\text{SS,L}}^{k=v}(t_j)} \quad 80$$

$$\text{COP}_{\text{SS,L}}^{k=v}(t_j) = a + b \cdot t_j + c \cdot t_j^2 \quad 81$$

Where,

$$a = \text{COP}_{\text{SS}}^{k=2}(t_{\text{IIL}}) - b \cdot t_{\text{IIL}} - c \cdot t_{\text{IIL}}^2 \quad 82$$

$$b = \frac{\text{COP}_{\text{SS}}^{k=1}(t_{\text{IL}}) - \text{COP}_{\text{SS}}^{k=2}(t_{\text{IIL}}) - d \cdot [\text{COP}_{\text{SS}}^{k=1}(t_{\text{IL}}) - \text{COP}_{\text{SS}}^{k=i}(t_{\text{VL}})]}{t_{\text{IL}} - t_{\text{IIL}} - d \cdot [t_{\text{IL}} - t_{\text{IIL}}]} \quad 83$$

$$c = \frac{\text{COP}_{\text{SS}}^{k=1}(t_{\text{HL}}) - \text{COP}_{\text{SS}}^{k=2}(t_{\text{HL}}) - b[(t_{\text{HL}}) - (t_{\text{HL}})]}{t_{\text{HL}}^2 - t_{\text{HL}}^2} \quad 84$$

$$d = \frac{t_{\text{HL}}^2 - t_{\text{HL}}^2}{t_{\text{VL}}^2 - t_{\text{HL}}^2} \quad 85$$

Where:

$$\text{COP}_{\text{SS}}^{k=1}(t_{\text{HL}}) = \frac{\dot{q}_{\text{SS}}^{k=1}(t_{\text{HL}})}{\dot{E}_{\text{SS}}^{k=1}(t_{\text{HL}})} \quad 86$$

$$\text{COP}_{\text{SS}}^{k=2}(t_{\text{HL}}) = \frac{\dot{q}_{\text{SS}}^{k=2}(t_{\text{HL}})}{\dot{E}_{\text{SS}}^{k=2}(t_{\text{HL}})} \quad 87$$

$$\text{COP}_{\text{SS}}^{k=i}(t_{\text{VL}}) = \frac{\dot{q}_{\text{SS}}^{k=i}(t_{\text{VL}})}{\dot{E}_{\text{SS}}^{k=i}(t_{\text{VL}})} \quad 88$$

The outdoor temperature t_{VL} is the temperature at which the Total Walk-in System Heat Load equals system net capacity when the compressor operates at its intermediate capacity ($k = i$) during the Low Load Period.

$$\text{BL}(t_j) = [0.33 \cdot \text{BLH}(t_j) + 0.67 \cdot \text{BLL}(t_j)] \cdot n_j \quad 89$$

$$\text{E}(t_j) = [0.33 \cdot \dot{E}_{\text{SS,H}}^{k=v}(t_j) + 0.67 \cdot \dot{E}_{\text{SS,L}}^{k=v}(t_j) + \text{DF}] \cdot n_j \quad 90$$

7.6.1.4 Case IV. High Capacity Running Continuously During High Load Period and Intermediate Capacity Running Continuously During Low Load Period ($t_{\text{IHL}} < t_j$). During a Low Load Period, units operate at variable compressor capacities ($k = v$). The compressor varies the capacity between its minimum and maximum capacities, and continuously operate to match the total walk-in system load at temperature t_j . During a high-load period, units operate at maximum ($k = 2$) compressor capacity continuously. The terms of defrost power contributing to the box load, \dot{Q}_{DF} , and to the system power consumption, DF , in these equations shall only be applied to the walk-in freezer systems, and shall be set to zero during the calculation for the walk-in refrigerator systems.

$$\text{WLH}(t_j) = \text{BLH}(t_j) + \dot{Q}_{\text{DF}} \quad 91$$

$$\text{WLL}(t_j) = \text{BLL}(t_j) + \dot{Q}_{\text{DF}} \quad 92$$

$$\text{BL}(t_j) = [0.33 \cdot \text{BLH}(t_j) + 0.67 \cdot \text{BLL}(t_j)] \cdot n_j \quad 93$$

$$\text{E}(t_j) = [0.33 \cdot \dot{E}_{\text{SS}}^{k=2}(t_j) + 0.67 \cdot \dot{E}_{\text{SS,L}}^{k=v}(t_j) + \text{DF}] \cdot n_j \quad 94$$

7.7 *Walk-in Box and Condensing Unit Located in Conditioned Space.* In such a case, the walk-in system load and the refrigeration system performance are independent to the outdoor ambient conditions. The AWEF is calculated by the following equations. The terms of defrost power contributing to the box load, \dot{Q}_{DF} , and to the system power consumption, $\dot{D}F$, in these equations shall only be applied to the walk-in freezer systems, and shall be set to zero during the calculation for the walk-in refrigerator systems.

$$W\dot{L}H = B\dot{L}H + \dot{E}F_{comp,off} (1 - LFH) + \dot{Q}_{DF} \tag{95}$$

$$W\dot{L}L = B\dot{L}L + \dot{E}F_{comp,off} (1 - LFL) + \dot{Q}_{DF} \tag{96}$$

Where $B\dot{L}H$ and $B\dot{L}L$ for refrigerator and freezer systems are defined in Section 6.2.1 and 6.3.1 of this standard, respectively; and the Load Factors (LFH and LFL) are calculated as follows.

$$LFH = \frac{W\dot{L}H}{\dot{q}_{ss,ID}} = \frac{B\dot{L}H + \dot{E}F_{comp,off} + \dot{Q}_{DF}}{\dot{q}_{ss,ID} + \dot{E}F_{comp,off}} \tag{97}$$

$$LFL = \frac{W\dot{L}L}{\dot{q}_{ss,ID}} = \frac{B\dot{L}L + \dot{E}F_{comp,off} + \dot{Q}_{DF}}{\dot{q}_{ss,ID} + \dot{E}F_{comp,off}} \tag{98}$$

The Annual Walk-in Energy Factor, AWEF, is determined by

$$AWEF = \frac{0.33 \cdot B\dot{L}H + 0.67 \cdot B\dot{L}L}{0.33 \cdot [\dot{E}_{ss,ID} \cdot LFH + \dot{E}F_{comp,off} (1 - LFH)] + 0.67 \cdot [\dot{E}_{ss,ID} \cdot LFL + \dot{E}F_{comp,off} (1 - LFL)] + \dot{D}F} \tag{99}$$

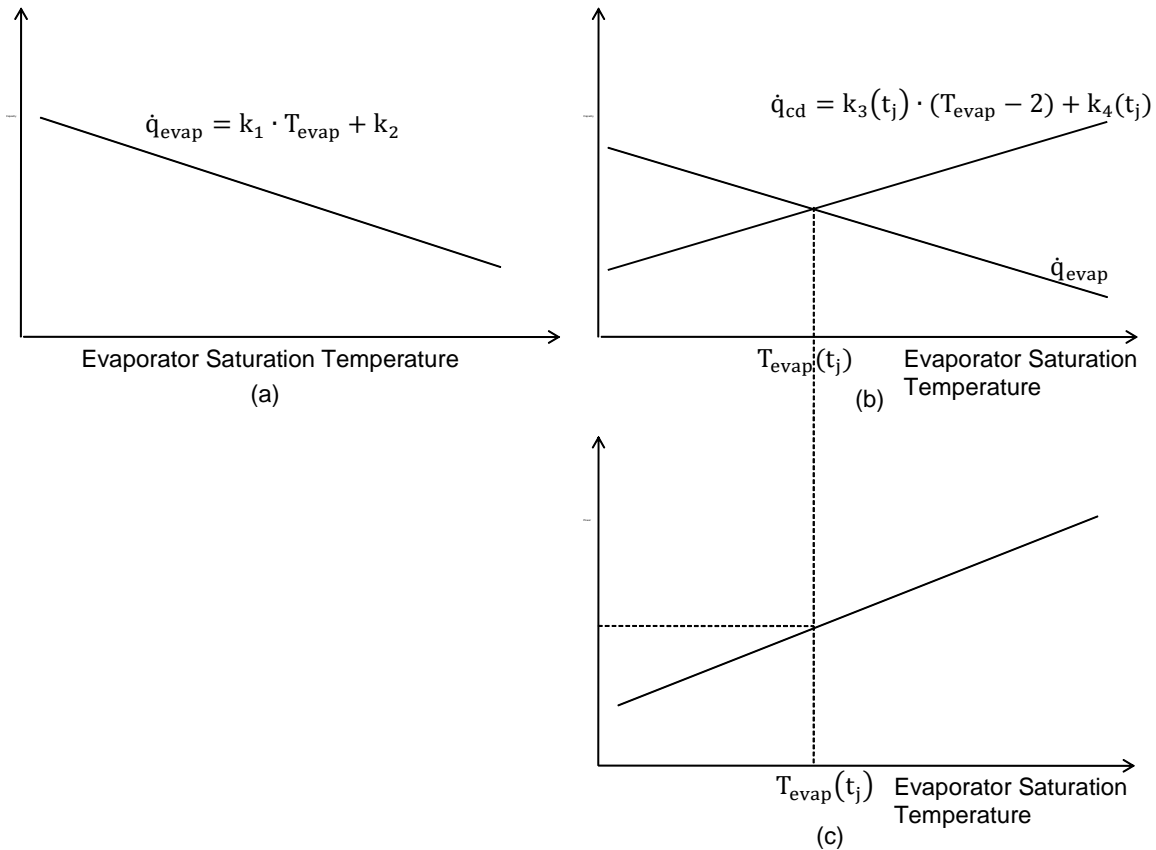

7.8 *Walk-in Unit Cooler (applied to all Unit Coolers sold separately)*

7.8.1 The following table (Table 17) from AHRI Standard 1200 defines the power required by the rack system to handle the walk-in Unit Cooler load:

| Medium Temperature | | Low Temperature | |
|--------------------|------|--------------------|------|
| Adjusted Dew Point | COP | Adjusted Dew Point | COP |
| °C | | °C | |
| -17.8 | 2.71 | -37.8 | 1.61 |
| -17.2 | 2.75 | -37.2 | 1.63 |
| -16.7 | 2.78 | -36.7 | 1.65 |
| -16.1 | 2.82 | -36.1 | 1.68 |
| -15.6 | 2.86 | -35.6 | 1.70 |
| -15.0 | 2.89 | -35.0 | 1.73 |
| -14.4 | 2.94 | -34.4 | 1.75 |
| -13.9 | 2.99 | -33.9 | 1.78 |
| -13.3 | 3.04 | -33.3 | 1.80 |
| -12.8 | 3.08 | -32.8 | 1.83 |
| -12.2 | 3.13 | -32.2 | 1.85 |
| -11.7 | 3.18 | -31.7 | 1.88 |
| -11.1 | 3.24 | -31.1 | 1.90 |
| -10.6 | 3.29 | -30.6 | 1.93 |
| -10.0 | 3.34 | -30.0 | 1.96 |
| -9.4 | 3.39 | -29.4 | 1.99 |
| -8.9 | 3.45 | -28.9 | 2.02 |
| -8.3 | 3.51 | -28.3 | 2.05 |
| -7.8 | 3.57 | -27.8 | 2.07 |
| -7.2 | 3.63 | -27.2 | 2.11 |
| -6.7 | 3.69 | -26.7 | 2.14 |
| -6.1 | 3.77 | -26.1 | 2.17 |
| -5.6 | 3.82 | -25.6 | 2.19 |
| -5.0 | 3.89 | -25.0 | 2.23 |
| -4.4 | 3.95 | -24.4 | 2.26 |
| -3.9 | 4.02 | -23.0 | 2.29 |
| -3.3 | 4.09 | -23.3 | 2.32 |
| -2.8 | 4.15 | -22.8 | 2.35 |
| -2.2 | 4.24 | -22.2 | 2.38 |
| -1.7 | 4.32 | -21.7 | 2.42 |
| -1.1 | 4.39 | -21.1 | 2.45 |
| -0.6 | 4.47 | -20.6 | 2.48 |
| 0.0 | 4.56 | -20.0 | 2.52 |
| 0.6 | 4.64 | -19.4 | 2.55 |
| 1.1 | 4.73 | -18.9 | 2.59 |
| 1.7 | 4.81 | -18.3 | 2.62 |

Note:

1. COP values at Medium and Low Temperature Applications are based on a typical reciprocating compressor.
2. Linear interpolation shall be used to calculate COP values for temperatures not shown in Table 17.

The Adjusted Dewpoint Value for a refrigerator application shall be -5 and for a freezer application it shall be -30°C , unless the Unit Cooler is rated at a suction dewpoint other than -4 for a refrigerator or -29 for a freezer, in which case the Adjusted Dewpoint Value shall be -16.5 less than the Unit Cooler rating suction dewpoint.

7.8.2 Unit Cooler with Fixed Evaporator Fan Speed.

7.8.2.1 The net capacity, $\dot{q}_{\text{mix,evap}}$ is determined from the test data for the Unit Cooler at the -4°C suction dewpoint for a refrigerator and the -29 suction dewpoint for a freezer. The power consumption of the system is calculated by.

$$\dot{E}_{\text{mix,rack}} = \frac{\dot{q}_{\text{mix,evap}} + \dot{E}F_{\text{comp,on}}}{\text{COP}(\text{Adjusted Dewpoint Value})} + \dot{E}F_{\text{comp,on}} \quad 100$$

In which, COP can be determined from Table 17 with corresponding adjusted dewpoint value.

7.8.2.2 The walk-in refrigerator system box load for the system during high and Low Load Periods shall be calculated by

$$B\dot{L}H = 0.7 \cdot \dot{q}_{\text{mix,evap}} \quad 101$$

$$B\dot{L}L = 0.1 \cdot \dot{q}_{\text{mix,evap}} \quad 102$$

7.8.2.3 The walk-in freezer system box load for the system during high and Low Load Periods shall be calculated by

$$B\dot{L}H = 0.8 \cdot \dot{q}_{\text{mix,evap}} \quad 103$$

$$B\dot{L}L = 0.4 \cdot \dot{q}_{\text{mix,evap}} \quad 104$$

7.8.2.4 The AWEF of the system is calculated by the following equations. The terms of defrost power contributing to the box load, \dot{Q}_{DF} , and to the system power consumption, $\dot{D}\dot{F}$, in these equations shall only be applied to the walk-in freezer systems, and shall be set to zero during the calculation for the walk-in refrigerator systems.

$$W\dot{L}H = B\dot{L}H + \dot{E}F_{\text{comp,off}} (1 - \text{LFH}) + \dot{Q}_{\text{DF}} \quad 105$$

$$W\dot{L}L = B\dot{L}L + \dot{E}F_{\text{comp,off}} (1 - \text{LFL}) + \dot{Q}_{\text{DF}} \quad 106$$

Where $B\dot{L}H$ and $B\dot{L}L$ for refrigerator and freezer systems are defined in Section 7.9.2.2 and 7.9.2.3 of this standard, respectively; and the Load Factors (LFH and LFL) are calculated as follows.

$$\text{LFH} = \frac{W\dot{L}H}{\dot{q}_{\text{mix,evap}}} = \frac{B\dot{L}H + \dot{E}F_{\text{comp,off}} + \dot{Q}_{\text{DF}}}{\dot{q}_{\text{mix,evap}} + \dot{E}F_{\text{comp,off}}} \quad 107$$

$$\text{LFL} = \frac{W\dot{L}L}{\dot{q}_{\text{mix,evap}}} = \frac{B\dot{L}L + \dot{E}F_{\text{comp,off}} + \dot{Q}_{\text{DF}}}{\dot{q}_{\text{mix,evap}} + \dot{E}F_{\text{comp,off}}} \quad 108$$

The Annual Walk-in Energy Factor, AWEF, is determined by

$$\text{AWEF} = \frac{0.33 \cdot B\dot{L}H + 0.67 \cdot B\dot{L}L}{0.33 \cdot [\dot{E}_{\text{mix,rack}} \cdot \text{LFH} + \dot{E}F_{\text{comp,off}} (1 - \text{LFH})] + 0.67 \cdot [\dot{E}_{\text{mix,rack}} \cdot \text{LFL} + \dot{E}F_{\text{comp,off}} (1 - \text{LFL})] + \dot{D}\dot{F}} \quad 109$$

7.8.3 Unit Cooler with Variable Speed Evaporator Fans. For Unit Coolers with variable speed evaporator fans that modulate fan speed in response to load, the fan shall be operated under its minimum, maximum and intermediate speed that equals to the average of the maximum and minimum speeds, respectively during the Unit Cooler test.

7.8.3.1 The evaporator net capacities, fan operating speed and the fan power consumptions under the three fan speeds shall be determined from the test data for the Unit Cooler at the -4°C suction dewpoint for a refrigerator and the -29°C suction dewpoint for a freezer, and correlated by the following equations.

$$s(\dot{q}_{\text{mix, evap}}) = k_7 + k_8 \cdot \dot{q}_{\text{mix, evap}} + k_9 \cdot \dot{q}_{\text{mix, evap}}^2 \quad 110$$

$$\dot{E}F_{\text{comp, on}}(s) = k_{10} + k_{11} \cdot s + k_{12} \cdot s^2 \quad 111$$

Where s stands for fan operating speed, and is a function of the coil net capacity; $k_7 \sim k_{12}$ are coefficients derived from evaporator coil test points.

7.8.3.2 The walk-in refrigerator system box load for the system during high and Low Load Periods can be calculated by

$$B\dot{L}H = 0.7 \cdot \dot{q}_{\text{mix, evap, max}} \quad 112$$

$$B\dot{L}L = 0.1 \cdot \dot{q}_{\text{mix, evap, max}} \quad 113$$

Where $\dot{q}_{\text{mix, evap, max}}$ is the net coil capacity under the maximum fan speed test point.

7.8.3.3 The walk-in freezer system box load for the system during high and Low Load Periods can be calculated by

$$B\dot{L}H = 0.8 \cdot \dot{q}_{\text{mix, evap, max}} \quad 114$$

$$B\dot{L}L = 0.4 \cdot \dot{q}_{\text{mix, evap, max}} \quad 115$$

Where $\dot{q}_{\text{mix, evap, max}}$ is the net coil capacity under the maximum fan speed test point.

7.8.3.4 The total walk-in system load during high and Low Load Periods can be calculated by

$$W\dot{L}H = B\dot{L}H + \dot{Q}_{\text{DF}} \quad 116$$

$$W\dot{L}L = B\dot{L}L + \dot{E}F_{\text{comp, off}}(1 - \text{LFL}) + \dot{Q}_{\text{DF}}, \text{ when } W\dot{L}L < \dot{q}_{\text{mix, evap, min}} \quad 117$$

$$W\dot{L}L = B\dot{L}L + \dot{Q}_{\text{DF}}, \text{ when } W\dot{L}L \geq \dot{q}_{\text{mix, evap, min}} \quad 118$$

Where $B\dot{L}H$ and $B\dot{L}L$ for refrigerator and freezer systems are defined in Section 7.9.3.2 and 7.9.3.3 of this standard, respectively; and the Load Factor during Low Load Period is calculated by

$$\text{LFL} = \frac{W\dot{L}L}{\dot{q}_{\text{mix, evap, min}}} = \frac{B\dot{L}L + \dot{E}F_{\text{comp, off}} + \dot{Q}_{\text{DF}}}{\dot{q}_{\text{mix, evap, min}} + \dot{E}F_{\text{comp, off}}} \quad 119$$

Where $\dot{q}_{\text{mix, evap, min}}$ is the net coil capacity under the minimum fan speed test point. The terms of defrost power contributing to the box load, \dot{Q}_{DF} , in these equations shall only be applied to the walk-in freezer systems, and shall be set to zero during the calculation for the walk-in refrigerator systems.

7.8.3.5 The power consumption of the system during the High And Low Load Periods are calculated by:

$$\dot{E}_{\text{mix, rack, H}} = \frac{W\dot{L}H + \dot{E}F_{\text{comp, on}}(s_H)}{\text{COP}(\text{Adjusted Dewpoint Value})} + \dot{E}F_{\text{comp, on}}(s_H) \quad 120$$

Where, the evaporator fan speed during the High Load Period, s_H , results in a coil capacity which matches $W\dot{L}H$, the combined box and defrost load during the High Load Period.

$$\dot{E}_{mix, rack, L} = \frac{W\dot{L}L + \dot{E}F_{comp, on}(s_L)}{COP \text{ (Adjusted Dewpoint Value)}} + \dot{E}F_{comp, on}(s_L), \text{ when } W\dot{L}L \geq \dot{q}_{mix, evap, min} \quad 121$$

Where, the evaporator fan speed during the Low Load Period, s_L , results in a coil capacity at that speed, which matches $W\dot{L}L$, the combined box and defrost load during the Low Load Period.

$$\dot{E}_{mix, rack, L} = \frac{\dot{q}_{mix, evap, min} + \dot{E}F_{comp, on}(s_{min})}{COP \text{ (Adjusted Dewpoint Value)}} + \dot{E}F_{comp, on}(s_{min}), \text{ when } W\dot{L}L < \dot{q}_{mix, evap, min} \quad 122$$

Where, fan speed during the Low Load Period, matches the minimum tested fan speed, s_{min} , because at the minimum fan speed the coil capacity exceeds $W\dot{L}L$, the combined box and defrost load during the Low Load Period.

In the above equations, COP can be determined from Table 17; s_{min} is the minimum operating speed of the evaporator fan; s_H and s_L are fan operating speeds under the High and Low Load Periods, respectively, and determined by

$$s_H = k_7 + k_8 \cdot W\dot{L}H + k_9 \cdot W\dot{L}H^2 \quad 123$$

$$s_L = k_7 + k_8 \cdot W\dot{L}L + k_9 \cdot W\dot{L}L^2 \quad 124$$

7.8.3.6 The system Annual Walk-in Energy Factor, AWEF, is determined by the following equations.

If $W\dot{L}L \geq \dot{q}_{mix, evap, min}$, then

$$AWEF = \frac{0.33 \cdot B\dot{L}H + 0.67 \cdot B\dot{L}L}{0.33 \cdot \dot{E}_{mix, rack, H} + 0.67 \cdot \dot{E}_{mix, rack, L} + D\dot{F}} \quad 125$$

If $W\dot{L}L < \dot{q}_{mix, evap, min}$, then

$$AWEF = \frac{0.33 \cdot B\dot{L}H + 0.67 \cdot B\dot{L}L}{0.33 \cdot \dot{E}_{mix, rack, H} + 0.67 \cdot [\dot{E}_{mix, rack, L} \cdot LFL + \dot{E}F_{comp, off}(1 - LFL)] + D\dot{F}} \quad 126$$

The terms of defrost power contributing to the system power consumption, $D\dot{F}$, in the above equations shall only be applied to the walk-in freezer systems, and shall be set to zero during the calculation for the walk-in refrigerator systems.

7.9 Remote Fixed Capacity Condensing Units Serving Walk-ins.

Table 18. Unit Cooler Nominal Values for Condensing Unit Energy Calculations

| Description | Cooler | Freezer |
|--|-------------------------------------|---------|
| Saturated Suction Temperature, °C | -4 | -29 |
| On-cycle evaporator fan power, per W of gross capacity at ambient condition, W/W | 0.055 | 0.055 |
| Off-cycle evaporator fan power, W | 0.2 x on-cycle evaporator fan power | |
| Electric defrost energy per cycle, per W of gross capacity, W-h/cycle per W | 0 | 0.41 |
| Number of cycles per day | N/A | 4 |
| Daily electric defrost contribution, W-h | 0.95 x daily defrost energy use | |

7.9.1 *Indoor Condensing Units Serving Walk-in Refrigerators.* The condensing unit shall be tested at the Capacity A, Suction A test conditions in Table 11. Electrical energy consumption by the condensing unit shall be measured during on-cycle periods $\dot{E}_{\text{CU, on}}$.

7.9.1.1 When the condensing unit is on, its steady state gross capacity, $\dot{Q}_{\text{gross}}(t_j)$, is reduced by the heat content of on-cycle evaporator fan power, $\dot{E}F_{\text{comp, on}}$, to yield its net capacity, $\dot{q}_{\text{ss}}(t_j)$.

The reference evaporator has an on-cycle evaporator fan power, in Watts, as a function of condensing unit gross capacity:

$$\dot{E}F_{\text{comp, on}} = 0.055 \cdot \dot{Q}_{\text{gross, ID}} \quad 127$$

$$\dot{q}_{\text{ss, ID}} = \dot{Q}_{\text{gross, ID}} - \dot{E}F_{\text{comp, on}} = \dot{Q}_{\text{gross, ID}} \cdot [1 - 0.055] \quad 128$$

$$\dot{q}_{\text{ss, ID}} = \dot{Q}_{\text{gross, ID}} \cdot 0.945 \quad 129$$

7.9.1.2 For purpose of this calculation, one third of the time the Walk-in Box Load is assumed to be high, $B\dot{L}H$, at 70% of the refrigeration system steady state net capacity, and two thirds of the time the Walk-in Box Load is assumed to be low, $B\dot{L}L$, at 10% of the refrigeration system steady state net capacity.

$$B\dot{L}H = 0.7 \cdot \dot{q}_{\text{ss, ID}} = 0.7 \cdot \dot{Q}_{\text{gross, ID}} \cdot 0.945 = 0.662 \cdot \dot{Q}_{\text{gross, ID}} \quad 130$$

$$B\dot{L}L = 0.1 \cdot \dot{q}_{\text{ss, ID}} = 0.1 \cdot \dot{Q}_{\text{gross, ID}} \cdot 0.945 = 0.0945 \cdot \dot{Q}_{\text{gross, ID}} \quad 131$$

7.9.1.3 The Total Walk-in System Heat Load at High Load Periods and Low Load Periods, $W\dot{L}H$ and $W\dot{L}L$ respectively, includes the box heat load and the heat load from the fan energy when the condensing unit compressor is off. This in turn can be used to calculate the fraction of time that the compressor is on during High load and Low Load Periods, LFH and LFL respectively.

$$W\dot{L}H = B\dot{L}H + \dot{E}F_{\text{comp, off}}(1 - \text{LFH}) \quad 132$$

$$W\dot{L}L = B\dot{L}L + \dot{E}F_{\text{comp, off}}(1 - \text{LFL}) \quad 133$$

Where $\dot{E}F_{\text{comp, off}}$ is assumed to consume 20% of the energy as $\dot{E}F_{\text{comp, on}}$; and the Load Factors (LFH and LFL) are calculated as follows.

$$\dot{E}F_{\text{comp, off}} = 0.2 \cdot \dot{E}F_{\text{comp, on}} = 0.2 \cdot 0.055 \cdot \dot{Q}_{\text{gross, ID}} = 0.011 \cdot \dot{Q}_{\text{gross, ID}} \quad 134$$

$$\text{LFH} = \frac{W\dot{L}H}{\dot{q}_{\text{ss, ID}}} = \frac{B\dot{L}H + \dot{E}F_{\text{comp, off}}}{\dot{q}_{\text{ss, ID}} + \dot{E}F_{\text{comp, off}}} \quad 135$$

$$\text{LFH} = \frac{0.7 \cdot \dot{q}_{\text{ss, ID}} + 0.011 \cdot \dot{Q}_{\text{gross, ID}}}{\dot{q}_{\text{ss, ID}} + 0.011 \cdot \dot{Q}_{\text{gross, ID}}} = \frac{(0.7)(0.945) \cdot \dot{Q}_{\text{gross, ID}} + 0.011 \cdot \dot{Q}_{\text{gross, ID}}}{0.945 \cdot \dot{Q}_{\text{gross, ID}} + 0.011 \cdot \dot{Q}_{\text{gross, ID}}} = 0.703 \quad 136$$

$$\text{LFL} = \frac{W\dot{L}L}{\dot{q}_{\text{ss, ID}}} = \frac{0.1 \cdot \dot{q}_{\text{ss, ID}} + \dot{E}F_{\text{comp, off}}}{\dot{q}_{\text{ss, ID}} + \dot{E}F_{\text{comp, off}}} \quad 137$$

$$\text{LFL} = \frac{0.1 \cdot \dot{q}_{\text{ss, ID}} + 0.011 \cdot \dot{Q}_{\text{gross, ID}}}{\dot{q}_{\text{ss, ID}} + 0.011 \cdot \dot{Q}_{\text{gross, ID}}} = \frac{(0.1)(0.945) \cdot \dot{Q}_{\text{gross, ID}} + 0.011 \cdot \dot{Q}_{\text{gross, ID}}}{0.945 \cdot \dot{Q}_{\text{gross, ID}} + 0.011 \cdot \dot{Q}_{\text{gross, ID}}} = 0.110 \quad 138$$

7.9.1.4 The Annual Walk-in Energy Factor, AWEF, is determined by a calculation that is a function of two measurements: steady state gross capacity, $\dot{Q}_{\text{gross}}(t_j)$, and steady state electrical consumption by the condensing unit measured during on-cycle periods $\dot{E}_{\text{CU, on}}$.

$$AWEF = \frac{0.33 \cdot BLH + 0.67 \cdot BLL}{0.33 \cdot [(\dot{E}_{CU,on} + \dot{E}F_{comp,on}) \cdot LFH + (\dot{E}F_{comp,off})(1 - LFH)] + 0.67 \cdot [(\dot{E}_{CU,on} + \dot{E}F_{comp,on}) \cdot LFL + (\dot{E}F_{comp,off})(1 - LFL)]} \quad 139$$

$$AWEF = \frac{(0.33)(0.662) \cdot \dot{Q}_{gross,ID} + (0.67)(0.0945) \cdot \dot{Q}_{gross,ID}}{0.33 \cdot [(\dot{E}_{CU,on} + 0.055 \cdot \dot{Q}_{gross,ID}) \cdot 0.703 + (0.011 \cdot \dot{Q}_{gross,ID})(1 - 0.703)] + 0.67 \cdot [(\dot{E}_{CU,on} + 0.055 \cdot \dot{Q}_{gross,ID}) \cdot 0.110 + (0.011 \cdot \dot{Q}_{gross,ID})(1 - 0.110)]} \quad 140$$

$$AWEF = \frac{0.282 \cdot \dot{Q}_{gross,ID}}{0.306 \cdot \dot{E}_{CU,on} + 0.14 \cdot \dot{Q}_{gross,ID}} \quad 141$$

7.9.2 Outdoor Condensing Units Serving Walk-in Refrigerators. The condensing unit shall be tested at the Capacity A, Suction A; Capacity B, Suction A and Capacity C, Suction A test conditions in Table 12. Electrical energy consumption by the condensing unit shall be measured at the three ambient outdoor temperature conditions listed in Table 12 during on-cycle periods $\dot{E}_{CU,on}(t)$. The steady state gross capacity, $\dot{Q}_{gross}(t_j)$ shall also be measured at the three ambient outdoor temperature conditions listed in Table 12 during on-cycle periods.

7.9.2.1 When the condensing unit is on, its steady state gross capacity, $\dot{Q}_{gross}(t_j)$ is reduced by the heat content of on-cycle evaporator fan power, $\dot{E}F_{comp,on}$, to yield its steady state net capacity, $\dot{q}_{ss}(t)$.

The reference evaporator has an on-cycle evaporator fan power, in Watts, as a function of condensing unit gross capacity:

$$\dot{E}F_{comp,on} = 0.055 \times \dot{Q}_{gross,A} \quad 142$$

$$\dot{q}_{ss}(t_j) = \dot{Q}_{gross}(t_j) - \dot{E}F_{comp,on} = \dot{Q}_{gross}(t_j) - 0.055 \cdot \dot{Q}_{gross,A} \quad 143$$

$$\dot{q}_{ss}(t_j) = \dot{Q}_{gross}(t_j) - 0.055 \cdot \dot{Q}_{gross,A} \quad 144$$

The steady state net capacity at 35, is used to calculate the Walk-in Box Load and can be simplified

$$\dot{q}_{ss,A} = \dot{Q}_{gross,A} - \dot{E}F_{comp,on} = \dot{Q}_{gross,A} [1 - 0.055] = \dot{Q}_{gross,A} \times 0.945 \quad 145$$

7.9.2.2 For purpose of this calculation, one third of the time the Walk-in Box Load is assumed to be high, BLH, and two thirds of the time the Walk-in Box Load is assumed to be low, BLL. These box load terms, BLH and BLL are a function of the refrigeration system steady state net capacity at 35°C and outdoor air temperature, t_j .

$$BLH(t_j) = 0.65 \cdot \dot{q}_{ss,A} + 0.05 \cdot \frac{\dot{q}_{ss,A} \cdot (t_j - 2)}{33} = 0.945 \cdot \left[0.65 \cdot \dot{Q}_{gross,A} + 0.05 \cdot \frac{\dot{Q}_{gross,A} \cdot (t_j - 2)}{33} \right] \quad 146$$

$$BLH(t_j) = [0.614 + 0.001432 \cdot (t_j - 2)] \cdot \dot{Q}_{gross,A} \quad 147$$

$$\begin{aligned} BLL(t_j) &= 0.03 \cdot \dot{q}_{ss,A} + 0.07 \cdot \frac{\dot{q}_{ss,A} \cdot (t_j - 2)}{33} \\ &= 0.945 \cdot \left[0.03 \cdot \dot{Q}_{gross,A} + 0.07 \cdot \frac{\dot{Q}_{gross,A} \cdot (t_j - 2)}{33} \right] \end{aligned} \quad 148$$

$$BLL(t_j) = [0.0284 + 0.002 \cdot (t_j - 2)] \cdot \dot{Q}_{gross,A} \quad 149$$

7.9.2.3 The Total Walk-in System Heat Load at High Load Periods and Low Load Periods, $W\dot{L}H$ and $W\dot{L}L$ respectively, includes the box heat load and the heat load from the fan energy when the condensing unit compressor is off. This in turn can be used to calculate the fraction of time that the compressor is on during high load and Low Load Periods, LFH and LFL respectively.

$$W\dot{L}H(t_j) = B\dot{L}H(t_j) + E\dot{F}_{\text{comp,off}}(1 - LFH(t_j)) \quad 150$$

$$W\dot{L}L(t_j) = B\dot{L}L(t_j) + E\dot{F}_{\text{comp,off}}(1 - LFL(t_j)) \quad 151$$

Where

$E\dot{F}_{\text{comp,off}}$ is assumed to consume 20% of the energy as $E\dot{F}_{\text{comp,on}}$; and the Load Factors (LFH and LFL) are calculated as follows.

$$E\dot{F}_{\text{comp,off}} = 0.2 \times E\dot{F}_{\text{comp,on}} = 0.2 \times 0.055 \times \dot{Q}_{\text{gross,A}} = 0.011 \times \dot{Q}_{\text{gross,A}} \quad 152$$

$$LFH(t_j) = \frac{W\dot{L}H(t_j)}{\dot{q}_{\text{ss}}(t_j)} = \frac{B\dot{L}H(t_j) + E\dot{F}_{\text{comp,off}}}{\dot{q}_{\text{ss}}(t_j) + E\dot{F}_{\text{comp,off}}} \quad 153$$

$$LFH(t_j) = \frac{[0.614 + 0.001432 \cdot (t_j - 2)] \cdot \dot{Q}_{\text{gross,A}} + 0.011 \cdot \dot{Q}_{\text{gross,A}}}{\dot{Q}_{\text{gross}}(t_j) - 0.055 \cdot \dot{Q}_{\text{gross,A}} + 0.011 \cdot \dot{Q}_{\text{gross,A}}} \quad 154$$

$$LFH(t_j) = \frac{[0.625 + 0.001432 \cdot (t_j - 2)] \cdot \dot{Q}_{\text{gross,A}}}{\dot{Q}_{\text{gross}}(t_j) - 0.044 \cdot \dot{Q}_{\text{gross,A}}} \quad 155$$

$$LFL(t_j) = \frac{W\dot{L}L(t_j)}{\dot{q}_{\text{ss}}(t_j)} = \frac{B\dot{L}L(t_j) + E\dot{F}_{\text{comp,off}}}{\dot{q}_{\text{ss}}(t_j) + E\dot{F}_{\text{comp,off}}} \quad 156$$

$$LFL(t_j) = \frac{[0.0284 + 0.002 \cdot (t_j - 2)] \cdot \dot{Q}_{\text{gross,A}} + 0.011 \cdot \dot{Q}_{\text{gross,A}}}{\dot{Q}_{\text{gross}}(t_j) - 0.055 \cdot \dot{Q}_{\text{gross,A}} + 0.011 \cdot \dot{Q}_{\text{gross,A}}} \quad 157$$

$$LFL(t_j) = \frac{[0.0394 + 0.002 \cdot (t_j - 2)] \cdot \dot{Q}_{\text{gross,A}}}{\dot{Q}_{\text{gross}}(t_j) - 0.044 \cdot \dot{Q}_{\text{gross,A}}} \quad 158$$

Where $\dot{Q}_{\text{gross}}(t_j)$ is calculated from the measured condensing unit gross capacity at the ambient test conditions of 2°C, 15°C and 35°C as follows:

If $t_j \leq 15^\circ\text{C}$

$$\dot{Q}_{\text{gross}}(t_j) = \dot{Q}_{\text{gross,C}} + \frac{(\dot{Q}_{\text{gross,B}} - \dot{Q}_{\text{gross,C}})}{t_B - t_C} (t_j - t_C) \quad 159$$

If $t_j > 15^\circ\text{C}$

$$\dot{Q}_{\text{gross}}(t_j) = \dot{Q}_{\text{gross,B}} + \frac{(\dot{Q}_{\text{gross,A}} - \dot{Q}_{\text{gross,B}})}{t_A - t_B} (t_j - t_B) \quad 160$$

7.9.2.4 The Annual Walk-in Energy Factor, AWEF, is determined by a calculation that is a function of two measurements: steady state gross capacity, $\dot{Q}_{\text{gross}}(t_j)$, steady state electrical consumption by the condensing unit measured during on-cycle periods $\dot{E}_{\text{CU, on}}$. These calculations are weighted by the number of bin hours, n_j , from Table D-1 in Appendix D, for each of the 20 bin temperatures, t_j , in table D-1.

$$AWEF = \frac{\sum_{j=1}^{20} [0.33 \cdot BLH(t_j) + 0.67 \cdot BLL(t_j)] \cdot n_j}{\sum_{j=1}^{20} \left[\frac{0.33 \cdot [\dot{E}_{CU,on} + \dot{E}F_{comp,on}] \cdot LFH(t_j) + (\dot{E}F_{comp,off})(1 - LFH(t_j))}{0.67 \cdot [\dot{E}_{CU,on} + \dot{E}F_{comp,on}] \cdot LFL(t_j) + (\dot{E}F_{comp,off})(1 - LFL(t_j))] + \right] \cdot n_j} \quad 161$$

$$AWEF = \frac{\sum_{j=1}^{20} \{0.33 \cdot [0.614 + 0.001432 \cdot (t_j - 2)] + 0.67 \cdot [0.0284 + 0.002 \cdot (t_j - 2)]\} \cdot \dot{Q}_{gross,A} \cdot n_j}{\sum_{j=1}^{20} \left[\frac{0.33 \cdot \{\dot{E}_{CU,on} + 0.055 \cdot \dot{Q}_{gross,A}\} \cdot LFH(t_j) + [0.011 \cdot \dot{Q}_{gross,A}] \cdot [1 - LFH(t_j)]}{0.67 \cdot \{\dot{E}_{CU,on} + 0.055 \cdot \dot{Q}_{gross,A}\} \cdot LFL(t_j) + [0.011 \cdot \dot{Q}_{gross,A}] \cdot [1 - LFL(t_j)]} \right] \cdot n_j} \quad 162$$

$$AWEF = \frac{\sum_{j=1}^{20} [0.222 + 0.001813 \cdot (t_j - 2)] \cdot \dot{Q}_{gross,A} \cdot n_j}{\sum_{j=1}^{20} \left[\frac{\dot{Q}_{gross,A} \cdot [0.011 + 0.01452 \cdot LFH(t_j) + 0.02948 \cdot LFL(t_j)]}{\dot{E}_{CU,on}(t_j) \cdot [0.33 \cdot LFH(t_j) + 0.67 \cdot LFL(t_j)]} + \right] \cdot n_j} \quad 163$$

If $t_j \leq 15^\circ\text{C}$

$$\dot{E}_{CU,on}(t_j) = \dot{E}_{CU,on,C} + \frac{(\dot{E}_{CU,on,B} - \dot{E}_{CU,on,C})}{(t_B - t_C)} (t_j - t_C) \quad 164$$

If $t_j > 15$

$$\dot{E}_{CU,on}(t_j) = \dot{E}_{CU,on,B} + \frac{(\dot{E}_{CU,on,A} - \dot{E}_{CU,on,B})}{(t_A - t_B)} (t_j - t_B) \quad 165$$

7.9.3 Indoor Condensing Units Serving Walk-in Freezers. The condensing unit shall be tested at the Capacity A, Suction A test conditions in Table 13. Electrical energy consumption by the condensing unit shall be measured during on-cycle periods $\dot{E}_{CU,on}$.

7.9.3.1 When the condensing unit is on, its steady state gross capacity, $\dot{Q}_{gross}(t_j)$, is reduced by the heat content of on-cycle evaporator fan power, $\dot{E}F_{comp,on}$, to yield its net capacity, $\dot{q}_{ss}(t_j)$.

The reference evaporator has an on-cycle evaporator fan power, in Watts, as a function of condensing unit gross capacity:

$$\dot{E}F_{comp,on} = 0.055 \cdot \dot{Q}_{gross,ID} \quad 166$$

$$\dot{q}_{ss,ID} = \dot{Q}_{gross,ID} - \dot{E}F_{comp,on} = Q_{ref} [1 - 0.055] \quad 167$$

$$\dot{q}_{ss,ID} = \dot{Q}_{gross,ID} \cdot 0.945 \quad 168$$

7.9.3.2 For purpose of this calculation, one third of the time the Walk-in Box Load is assumed to be high, BLH , at 80% of the refrigeration system steady state net capacity, and two thirds of the time the Walk-in Box Load is assumed to be low, BLL , at 40% of the refrigeration system steady state net capacity.

$$BLH = 0.8 \cdot \dot{q}_{ss,ID} = 0.8 \cdot \dot{Q}_{gross,ID} \cdot 0.945 = 0.756 \cdot \dot{Q}_{gross,ID} \quad 169$$

$$BLL = 0.4 \cdot \dot{q}_{ss,ID} = 0.4 \cdot \dot{Q}_{gross,ID} \cdot 0.945 = 0.378 \cdot \dot{Q}_{gross,ID} \quad 170$$

7.9.3.3 Walk-in System High Load, WLH , and Walk-in System Low Load, WLL , include the box heat load and the heat load from the fan energy when the condensing unit compressor is off. This in turn can be used to calculate the fraction of time that the compressor is on during High Load and Low Load Periods, LFH and LFL respectively.

$$WLH = BLH + \dot{E}F_{comp,off} (1 - LFH) + Q_{DF} \quad 171$$

$$WLL = BLL + \dot{E}F_{\text{comp,off}} (1 - LFL) + Q_{DF} \quad 172$$

Where,

$\dot{E}F_{\text{comp,off}}$ is assumed to consume 20% of the energy as $\dot{E}F_{\text{comp,on}}$;

$$\dot{E}F_{\text{comp,off}} = 0.2 \cdot \dot{E}F_{\text{comp,on}} = 0.2 \cdot 0.055 \cdot \dot{Q}_{\text{gross,ID}} = 0.011 \cdot \dot{Q}_{\text{gross,ID}} \quad 173$$

Defrost energy for the reference Unit Cooler is assumed to be 0.41 W-h per cycle for each W of gross capacity, and defrost is expected to occur 4 times per 24 hour period.

The daily defrost energy contributions to Total Walk-in System Heat Loads, Q_{DF} , is 0.95 times electrical defrost load. The hourly defrost load is the daily defrost load divided by 24.

$$DF = 0.41 \text{ W-h} \cdot \dot{Q}_{\text{gross,ID}} \cdot 4 / 24 = 0.0683 \cdot \dot{Q}_{\text{gross,ID}} \quad 174$$

$$Q_{DF} = DF \cdot 0.95 = 0.0649 \cdot \dot{Q}_{\text{gross,ID}} \quad 175$$

The Load Factors (LFH and LFL) are calculated as follows.

$$LFH = \frac{WLH}{\dot{q}_{ss(32)}} = \frac{BLH + \dot{E}F_{\text{comp,off}} + Q_{DF}}{\dot{q}_{ss,ID} + \dot{E}F_{\text{comp,off}}} \quad 176$$

$$LFH = \frac{(0.8)(0.945) \cdot \dot{Q}_{\text{gross,ID}} + 0.011 \cdot \dot{Q}_{\text{gross,ID}} + 0.0649 \cdot \dot{Q}_{\text{gross,ID}}}{0.945 \cdot \dot{Q}_{\text{gross,ID}} + 0.011 \cdot \dot{Q}_{\text{gross,ID}}} = 0.870 \quad 177$$

$$LFL = \frac{WLL}{\dot{q}_{ss,ID}} = \frac{0.4 \cdot \dot{q}_{ss,ID} + \dot{E}F_{\text{comp,off}} + Q_{DF}}{\dot{q}_{ss,ID} + \dot{E}F_{\text{comp,off}}} \quad 178$$

$$LFL = \frac{(0.4)(0.945) \cdot \dot{Q}_{\text{gross,ID}} + 0.011 \cdot \dot{Q}_{\text{gross,ID}} + 0.0649 \cdot \dot{Q}_{\text{gross,ID}}}{0.945 \cdot \dot{Q}_{\text{gross,ID}} + 0.011 \cdot \dot{Q}_{\text{gross,ID}}} = 0.475 \quad 179$$

7.9.3.4 The Annual Walk-in Energy Factor, AWEF, is determined by a calculation that is a function of three measurements: steady state gross capacity, $\dot{Q}_{\text{gross}}(t_j)$, steady state electrical consumption by the condensing unit measured during on-cycle periods $\dot{E}_{\text{CU, on}}$, and electrical consumption by the condensing unit during off-cycle periods, $\dot{E}_{\text{CU, off}}$.

$$AWEF = \frac{0.33 \cdot BLH + 0.67 \cdot BLL}{0.33 \cdot [(\dot{E}_{\text{CU,on}} + \dot{E}F_{\text{comp,on}}) \cdot LFH + (\dot{E}F_{\text{comp,off}})(1 - LFH)] + 0.67 \cdot [(\dot{E}_{\text{CU,on}} + \dot{E}F_{\text{comp,on}}) \cdot LFL + (\dot{E}F_{\text{comp,off}})(1 - LFL)] + DF} \quad 180$$

$$AWEF = \frac{(0.33)(0.756) \cdot \dot{Q}_{\text{gross,ID}} + (0.67)(0.378) \cdot \dot{Q}_{\text{gross,ID}}}{0.33 \cdot [(\dot{E}_{\text{CU,on}} + 0.055 \cdot \dot{Q}_{\text{gross,ID}}) \cdot 0.870 + (0.011 \cdot \dot{Q}_{\text{gross,ID}})(1 - 0.870)] + 0.67 \cdot [(\dot{E}_{\text{CU,on}} + 0.055 \cdot \dot{Q}_{\text{gross,ID}}) \cdot 0.475 + (0.011 \cdot \dot{Q}_{\text{gross,ID}})(1 - 0.475)] + 0.0683 \cdot \dot{Q}_{\text{gross,ID}}} \quad 181$$

$$AWEF = \frac{0.503 \cdot \dot{Q}_{\text{gross,ID}}}{0.605 \cdot \dot{E}_{\text{CU,on}} + 0.106 \cdot \dot{Q}_{\text{gross,ID}}} \quad 182$$

7.9.4 *Outdoor Condensing Units Serving Walk-in Freezers.* The condensing unit shall be tested at the Capacity A, Suction A; Capacity B, Suction A and Capacity C, Suction A test conditions in Table 14. Electrical energy consumption by the condensing unit shall be measured at the three ambient outdoor temperature conditions listed in Table 14 during on-cycle periods $\dot{E}_{\text{CU,on}}$. The steady state gross capacity, $\dot{Q}_{\text{gross}}(t_j)$, shall also be measured at the three ambient outdoor temperature conditions listed in Table 14 during on-cycle periods.

7.9.4.1 When the condensing unit is on, its steady state gross capacity, $\dot{Q}_{gross}(t_j)$, is reduced by the heat content of on-cycle evaporator fan power, $\dot{E}F_{comp,on}$, to yield its steady state net capacity, $\dot{q}_{ss}(t_j)$.

The reference evaporator has an on-cycle evaporator fan power, in Watts, as a function of condensing unit gross capacity:

$$EF_{comp,on} = 0.055 \cdot \dot{Q}_{gross,A} \quad 183$$

$$\dot{q}_{ss}(t_j) = \dot{Q}_{gross}(t_j) - EF_{comp,on} = \dot{Q}_{gross}(t_j) - 0.055 \cdot \dot{Q}_{gross,A} \quad 184$$

$$\dot{q}_{ss}(t_j) = \dot{Q}_{gross}(t_j) - 0.055 \cdot \dot{Q}_{gross,A} \quad 185$$

The steady state net capacity at 35, is used to calculate the Walk-in Box Load and can be simplified:

$$\dot{q}_{ss}(35) = \dot{Q}_{gross,A} - EF_{comp,on} = \dot{Q}_{gross,A} [1 - 0.055] = \dot{Q}_{gross,A} \cdot 0.945 \quad 186$$

7.9.4.2 For purpose of this calculation, one third of the time the Walk-in Box Load is assumed to be high, BLH, and two thirds of the time the Walk-in Box Load is assumed to be low, BLL. These box load terms, BLH and BLL are a function of the refrigeration system steady state net capacity at 35 and outdoor air temperature, t_j .

$$BLH(t_j) = 0.55 \cdot \dot{q}_{ss,A} + 0.25 \cdot \frac{\dot{q}_{ss,A} \cdot (t_j + 23)}{58} = 0.945 \cdot \left[0.55 \cdot \dot{Q}_{gross,A} + 0.25 \cdot \frac{\dot{Q}_{gross,A} \cdot (t_j + 23)}{58} \right] \quad 187$$

$$BLH(t_j) = [0.52 + 0.0041 \cdot (t_j + 23)] \cdot Q_{ref,A} \quad 188$$

$$\begin{aligned} BLL(t_j) &= 0.15 \cdot \dot{q}_{ss,A} + 0.25 \cdot \frac{\dot{q}_{ss,A} \cdot (t_j + 23)}{58} \\ &= 0.945 \cdot \left[0.15 \cdot \dot{Q}_{gross,A} + 0.25 \cdot \frac{\dot{Q}_{gross,A} \cdot (t_j + 23)}{58} \right] \end{aligned} \quad 189$$

$$BLL(t_j) = [0.142 + 0.0041 \cdot (t_j + 23)] \cdot \dot{Q}_{gross,A} \quad 190$$

7.9.4.3 The Total Walk-in System Heat Load at High Load Periods and Low Load Periods, $\dot{W}LH$ and $\dot{W}LL$ respectively, includes the box heat load and the heat load from the fan energy when the condensing unit compressor is off. This in turn can be used to calculate the fraction of time that the compressor is on during High Load and Low Load Periods, LFH and LFL respectively.

$$\dot{W}LH(t_j) = BLH(t_j) + \dot{E}F_{comp,off} (1 - LFH(t_j)) + Q_{DF} \quad 191$$

$$\dot{W}LL(t_j) = BLL(t_j) + \dot{E}F_{comp,off} (1 - LFL(t_j)) + Q_{DF} \quad 192$$

Where

$\dot{E}F_{comp,off}$ is assumed to consume 20% of the energy as $\dot{E}F_{comp,on}$; and the Load Factors (LFH and LFL) are calculated as follows.

$$\dot{E}F_{comp,off} = 0.2 \cdot \dot{E}F_{comp,on} = 0.2 \cdot 0.055 \cdot \dot{Q}_{gross,A} = 0.011 \cdot \dot{Q}_{gross,A} \quad 193$$

Defrost energy for the reference Unit Cooler is assumed to be 0.41 W-h per cycle for each W of gross capacity, and defrost is expected to occur 4 times per 24 hour period.

The daily defrost energy contributions to Total Walk-in System Heat Loads, Q_{DF} , is 0.95 times electrical defrost load.

The hourly defrost load is the daily defrost load divided by 24.

$$DF = 0.41 \text{ W-h} \cdot \dot{Q}_{gross}(35) \cdot 4 / 24 = 0.0683 \cdot \dot{Q}_{gross,A} \quad 194$$

$$Q_{DF} = DF \cdot 0.95 = 0.0649 \cdot \dot{Q}_{gross,A} \quad 195$$

The Load Factors (LFH and LFL) are calculated as follows.

$$LFH = \frac{WLH}{\dot{q}_{ss}(t_j)} = \frac{BLH + \dot{E}F_{comp,off} + Q_{DF}}{\dot{q}_{ss}(t_j) + \dot{E}F_{comp,off}} \quad 196$$

$$LFH(t_j) = \frac{WLH(t_j)}{\dot{q}_{ss}(t_j)} = \frac{BLH(t_j) + \dot{E}F_{comp,off} + Q_{DF}}{\dot{q}_{ss}(t_j) + \dot{E}F_{comp,off}} \quad 197$$

$$LFH(t_j) = \frac{0.945 \cdot \left[0.55 \cdot \dot{Q}_{gross,A} + 0.25 \cdot \frac{\dot{Q}_{gross,A} \cdot (t_j + 23)}{58} \right] + 0.011 \cdot \dot{Q}_{gross,A} + 0.0649 \cdot \dot{Q}_{gross,A}}{[\dot{Q}_{gross}(t_j) - 0.055 \cdot \dot{Q}_{gross,A}] + 0.011 \cdot \dot{Q}_{gross,A}} \quad 198$$

$$LFH(t_j) = \frac{[0.5959 + 0.0041 \cdot (t_j + 23)] \cdot \dot{Q}_{gross,A}}{\dot{Q}_{gross}(t_j) - 0.044 \cdot \dot{Q}_{gross,A}} \quad 199$$

$$LFL(t_j) = \frac{WLL(t_j)}{\dot{q}_{ss}(t_j)} = \frac{BLL(t_j) + \dot{E}F_{comp,off} + Q_{DF}}{\dot{q}_{ss}(t_j) + \dot{E}F_{comp,off}} \quad 200$$

$$LFL(t_j) = \frac{0.9454 \cdot \left[0.15 \cdot \dot{Q}_{gross,A} + 0.25 \cdot \frac{\dot{Q}_{gross,A} \cdot (t_j + 23)}{58} \right] + 0.011 \cdot \dot{Q}_{gross,A} + 0.0649 \cdot \dot{Q}_{gross,A}}{\dot{Q}_{gross}(t_j) - 0.055 \cdot \dot{Q}_{gross,A} + 0.011 \cdot \dot{Q}_{gross,A}} \quad 201$$

$$LFL(t_j) = \frac{[0.218 + 0.0041 \cdot (t_j + 23)] \cdot \dot{Q}_{gross,A}}{\dot{Q}_{gross}(t_j) - 0.044 \cdot \dot{Q}_{gross,A}} \quad 202$$

Where $\dot{Q}_{gross}(t_j)$ is calculated from the measured condensing unit gross capacity at the ambient test conditions of 2°C, 15°C and 35°C as follows.

If $t_j \leq 15$

$$\dot{Q}_{gross}(t_j) = \dot{Q}_{gross,C} + \frac{(\dot{Q}_{gross,B} - \dot{Q}_{gross,C})}{t_B - t_C} (t_j - t_C) \quad 203$$

If $t_j > 15^\circ\text{C}$

$$\dot{Q}_{gross}(t_j) = \dot{q}_{ss,B} + \frac{(\dot{Q}_{gross,A} - \dot{Q}_{gross,B})}{t_A - t_B} (t_j - t_B) \quad 204$$

7.9.4.4 The Annual Walk-in Energy Factor, AWEF, is determined by a calculation that is a function of three measurements: steady state gross capacity, $\dot{Q}_{gross}(t_j)$, steady state electrical consumption by the condensing unit measured during on-cycle periods $\dot{E}_{CU, on}$, and electrical consumption by the condensing unit during off-

cycle periods, $\dot{E}_{CU, off}$. These calculations are weighted by the number of bin hours, n_j , from Table D-1 in Appendix D, for each of the 20 bin temperatures, t_j , in table D-1.

$$AWEF = \frac{\sum_{j=1}^{20} [0.33 \cdot BLH(t_j) + 0.67 \cdot BLL(t_j)] \cdot n_j}{\sum_{j=1}^{20} \left[\frac{0.33 \cdot [\dot{E}_{CU, on} + \dot{E}_{F_{comp, on}}] \cdot LFH(t_j) + (\dot{E}_{F_{comp, off}}) (1 - LFH(t_j))}{0.67 \cdot [\dot{E}_{CU, on} + \dot{E}_{F_{comp, on}}] \cdot LFL(t_j) + (\dot{E}_{F_{comp, off}}) (1 - LFL(t_j))} \right] \cdot n_j} \quad 205$$

$$AWEF = \frac{\sum_{j=1}^{20} \{0.33 \cdot [0.52 + 0.0041 \cdot (t_j + 23)] + 0.67 \cdot [0.142 + 0.0041 \cdot (t_j + 23)]\} \cdot \dot{Q}_{gross, A} \cdot n_j}{\sum_{j=1}^{20} \left[\frac{0.33 \cdot \{\dot{E}_{CU, on} + 0.055 \cdot \dot{Q}_{gross, A}\} \cdot LFH(t_j) + [0.011 \cdot \dot{Q}_{gross, A}] \cdot [1 - LFH(t_j)]}{0.67 \cdot \{\dot{E}_{CU, on} + 0.055 \cdot \dot{Q}_{gross, A}\} \cdot LFL(t_j) + [0.011 \cdot \dot{Q}_{gross, A}] \cdot [1 - LFL(t_j)]} \right] \cdot n_j} \quad 206$$

$$AWEF = \frac{\sum_{j=1}^{20} [0.267 + 0.0041 \cdot (t_j + 23)] \cdot \dot{Q}_{gross, A} \cdot n_j}{\sum_{j=1}^{20} \left[\frac{\dot{Q}_{gross, A} \cdot [0.011 + 0.0145 \cdot LFH(t_j) + 0.0295 \cdot LFL(t_j)]}{\dot{E}_{CU, on}(t_j) \cdot [0.33 \cdot LFH(t_j) + 0.67 \cdot LFL(t_j)]} \right] \cdot n_j} \quad 207$$

Where $\dot{E}_{CU, on}(t_j)$ and $\dot{E}_{CU, off}(t_j)$ is calculated from the measured condensing unit gross capacity at the ambient test conditions of 2°C, 15°C and 35°C as follows.

If $t_j \leq 15^\circ\text{C}$

$$\dot{E}_{CU, on}(t_j) = \dot{E}_{CU, on, C} + \frac{(\dot{E}_{CU, on, B} - \dot{E}_{CU, on, C})}{t_B - t_C} (t_j - t_C) \quad 208$$

$$\dot{E}_{CU, off}(t_j) = \dot{E}_{CU, off, C} + \frac{(\dot{E}_{CU, off, B} - \dot{E}_{CU, off, C})}{t_B - t_C} (t_j - t_C) \quad 209$$

If $t_j > 15^\circ\text{C}$

$$\dot{E}_{CU, on}(t_j) = \dot{E}_{CU, on, B} + \frac{(\dot{E}_{CU, on, A} - \dot{E}_{CU, on, B})}{t_A - t_B} (t_j - t_B) \quad 210$$

$$\dot{E}_{CU, off}(t_j) = \dot{E}_{CU, off, B} + \frac{(\dot{E}_{CU, off, A} - \dot{E}_{CU, off, B})}{t_A - t_B} (t_j - t_B) \quad 211$$

Section 8. Symbols and Subscripts

8.1 Symbols and Subscripts. The symbols and subscripts used in this standard are as follows:

| | |
|-------------------|---|
| AWEF: | Annual Walk-in Energy Factor, W·h/W·h |
| BL(t_j): | Heat removed from walk-in box that does not include the heat generated by the operation of refrigeration systems, W·h |
| BLH(t_j): | Non-equipment related Walk-in Box Load during High Load Period, W |
| BLL(t_j): | Non-equipment related Walk-in Box Load during Low Load Period, W |
| c_{pi} : | Specific heat of ice, J/g·K |
| c_{pw} : | Specific heat of water, J/g·K |
| DF: | Daily average defrost energy required for the refrigeration system, W·h |
| DF _f : | Energy input for a defrost cycle for frost coil condition, W·h |
| DF _d : | Energy input for a defrost cycle for dry coil condition, W·h |
| DF: | Defrost power consumption, W·h |

| | |
|-----------------------------------|--|
| $E(t_j)$: | System energy consumption at t_j , W·h |
| \dot{E}_c : | Total power consumption of the heater and auxiliary equipment of the calibrated box, W |
| $\dot{E}_{\text{mix,cd}}$: | Power consumption of the condensing unit for mix-match system, W |
| $\dot{E}_{\text{mix,rack}}$: | Power consumption of the rack system for mix-match system, W |
| $\dot{E}_{\text{mix,rack,H}}$: | Power consumption of the rack system for mix-match system during a High Load Period, W |
| $\dot{E}_{\text{mix,rack,L}}$: | Power consumption of the rack system for mix-match system during a Low Load Period, W |
| $\dot{E}_{\text{ss}}(t_j)$: | System steady state power consumption at t_j , including power consumptions of compressor(s), both condenser and evaporator fans, W |
| $\dot{E}_{\text{ss},X}^k$: | System steady state power consumption at Tests A, B, C, or ID ($X = A, B, C, \text{ or ID}$) where $k = 1, 2$ or i for Minimum Capacity, Maximum Capacity or Intermediate Capacity (See Section 5). No superscript designates a single capacity system |
| $\dot{E}F_{\text{comp,off}}$: | Evaporator fan power consumption during compressor off period, W |
| $\dot{E}F_{\text{comp,on}}$: | Evaporator fan power consumption during compressor on period, W |
| FS: | Fan speed (s), rpm [rev/s] |
| H: | Refrigerant enthalpy, J/g |
| H_{fus} : | Latent heat of fusion, J/g |
| i: | Intermediate compressor capacity case in which the compressor was tested at the designated testing condition. |
| j: | Bin Number |
| k: | Case Number, (1: low capacity or minimum capacity; 2: high capacity or maximum capacity; i: intermediate capacity; v: variable capacity) |
| $k_1 \sim k_6$: | coefficients from linear curve fit, W/°C |
| $k_7 \sim k_{12}$: | coefficients derived from evaporator coil test points |
| K_{cb} : | Heat leakage coefficient of calibrated box, W/°C |
| LFH: | Load Factor during High Load Period |
| LFL: | Load Factor during Low Load Period |
| \dot{m}_{ref} : | Refrigerant mass flow rate, g/s |
| $\dot{m}_{\text{ref},1}$: | Refrigerant mass flow rate measured at subcooled refrigerant liquid line (1 st independent measurement), g/s |
| $\dot{m}_{\text{ref},2}$: | Refrigerant mass flow rate measured at subcooled or superheated refrigerant vapor line (2 nd independent measurement), g/s |
| m_w : | Weight of the drained water from defrost, g |
| n_j : | Bin hours, hr |
| N: | Number of motors |
| N_{DF} : | Number of defrost per day |
| P_b : | Barometric pressure, kPa |
| $q(t_j)$: | Heat removed from the walk-in box at t_j , J |
| $\dot{q}_{\text{ss}}(t_j)$: | System steady state Net Refrigeration Capacity at t_j , W |
| $\dot{q}_{\text{mix,cd}}$: | Condensing unit capacity for mix-match system, W |
| $\dot{q}_{\text{mix,evap}}$: | Evaporator coil net capacity for mix-match system, W |
| $\dot{Q}_{\text{mix,evap,max}}$: | net coil capacity under the maximum fan speed test point, W |
| \dot{Q}_{air} : | Air-side Gross Refrigeration Capacity, W |
| Q_{DF} : | Daily contribution of load attributed to defrost, W·h |
| \dot{Q}_{DF} : | Defrost power consumption contributed to the box load, W |
| \dot{Q}_{gross} : | Gross condensing unit Refrigeration Capacity, W |
| $\dot{Q}_{\text{gross},X}$: | Gross condensing unit Refrigeration Capacity at Tests A, B, C or ID ($X = A, B, C \text{ or ID}$) where $k = 1, 2$ or i for Minimum Capacity, Maximum Capacity or Intermediate Capacity (See Section 5). No superscript designates a single capacity system. |
| $\dot{Q}_{\text{mix,evap}}$: | Coil gross capacity for mix-match system, W |
| \dot{Q}_t : | Gross total Refrigeration Capacity, W |
| \dot{Q}_{ref} : | Refrigerant-side gross capacity, W |
| $\dot{Q}_{\text{ref},1}$: | Refrigerant-side gross capacity calculated based on the first independent measurement, W |

| | |
|----------------------------|---|
| $\dot{Q}_{\text{ref},2}$: | Refrigerant-side gross capacity calculated based on the second independent measurement, W |
| S_H : | Evaporator fan speed resulting in a coil capacity which matches walk-in system load during a High Load Period, rpm |
| S_L : | Evaporator fan speed resulting in a coil capacity which matches walk-in system load during a Low Load Period, rpm |
| s_{min} : | Minimum evaporator fan speed, rpm |
| T_{cb} : | Average dry-bulb temperature of the air within the calibrated box, °C |
| T_{cn} : | Average dry-bulb temperature of the air within the temperature controlled enclosure, °C |
| T_{evap} : | Evaporating temperature, °C |
| T_{db} : | Dry-bulb temperature of air at inlet, °C |
| T_{dp} : | Dew point temperature of air at inlet, °C |
| T_{wb} : | Wet-bulb temperature of air at inlet, °C |
| T_w : | Temperature of the drained water from defrost, °C |
| t_j : | Bin temperature, °C |
| t_A : | Test A condenser air temperature, 35°C |
| t_B : | Test B condenser air temperature, 15°C |
| t_C : | Test C condenser air temperature, 2°C |
| t_{IH} : | The outdoor temperature at which the Total Walk-in System Heat Load equals system net capacity when the compressor operates at low or minimum capacity ($k = 1$) during the High Load Period, °C |
| t_{IHH} : | The outdoor temperature at which the Total Walk-in System Heat Load equals system net capacity when the compressor operates at high or maximum capacity ($k = 2$) during the High Load Period, °C |
| t_{IL} : | The outdoor temperature at which the Total Walk-in System Heat Load equals system net capacity when the compressor operates at low or minimum capacity ($k = 1$) during the Low Load Period, °C |
| t_{ILL} : | The outdoor temperature at which the Total Walk-in System Heat Load equals system net capacity when the compressor operates at high or maximum capacity ($k = 2$) during the Low Load Period, °C |
| t_{VH} : | The outdoor temperature at which the unit, when operating at the intermediate capacity that is tested under the designated condition, provides a Refrigeration Capacity that is equal to the Total Walk-in System Heat Load during High Load Period, °C |
| t_{VL} : | The outdoor temperature at which the unit, when operating at the intermediate capacity that is tested under the designated condition, provides a Refrigeration Capacity that is equal to the Total Walk-in System Heat Load during Low Load Period, °C |
| V : | Voltage of each phase, V |
| \dot{V}_{air} : | Air volumetric flow rate, m ³ /s |
| $WLH(t_j)$: | Total Walk-in System Heat Load during High Load Period, W |
| $WLL(t_j)$: | Total Walk-in System Heat Load during Low Load Period, W |

Subscript

| | |
|------|--|
| A: | Test A at 35°C |
| B: | Test B at 15°C |
| C: | Test C at 2°C |
| H: | High Load Period |
| ID: | Indoor unit at 32°C |
| in: | Inlet |
| L: | Low Load Period |
| out: | Outlet |
| ss: | Steady state |
| v: | Variable compressor capacity case in which the compressor was operated at any capacity between the max and min capacities. |

Section 9. Minimum Requirements for Published Ratings

9.1 *Minimum Data Requirements for Published Ratings.* As a minimum, Published Ratings shall include all Standard Ratings. All claims to ratings within the scope of this standard shall include the statement “Rated in accordance with ANSI/AHRI Standard 1251 (SI)”. All claims to ratings outside the scope of this standard shall include the statement “Outside the scope of ANSI/AHRI Standard 1251 (SI)”. Wherever Application Ratings are published or printed, they shall include a statement of the conditions at which the ratings apply.

Section 10. Marking and Nameplate Data

10.1 *Marking and Nameplate Data.* As a minimum, the manufacturer name or trade-name; model number; refrigerant(s); current, A; voltage, V; frequency, Hz; and phase shall be shown in a conspicuous place on the unit.

Nameplate voltages for 60 Hertz systems shall include one or more of the equipment nameplate voltage ratings shown in Table 1 of ANSI/AHRI Standard 110. Nameplate voltages for 50 Hertz systems shall include one or more of the utilization voltages shown in Table 1 of IEC Standard 60038.

Section 11. Conformance Conditions

11.1 *Conformance.* While conformance with this standard is voluntary, conformance shall not be claimed or implied for products or equipment within the standard’s *Purpose* (Section 1) and *Scope* (Section 2) unless such product claims meet all of the requirements of the standard and all of the testing and rating requirements are measured and reported in complete compliance with the standard. Any product that has not met all the requirements of the standard shall not reference, state, or acknowledge the standard in any written, oral, or electronic communication.

APPENDIX A. REFERENCES – NORMATIVE

A1. Listed here are all standards, handbooks, and other publications essential to the formation and implementation of the standard. All references in this appendix are considered as part of this standard.

A1.1 ANSI/AHRI Standard 110-2012, *Air-Conditioning, Heating and Refrigerating Equipment Nameplate Voltages*, 2012, Air-Conditioning, Heating, and Refrigeration Institute, 2111 Wilson Blvd., Suite 500, Arlington, VA 22201, U.S.A.

A1.2 ANSI/AHRI Standard 210/240-2008 with Addenda 1 and 2, *Performance Rating of Unitary Air-Conditioning and Air-Source Heat Pump Equipment*, 2008, Air-Conditioning, Heating and Refrigeration Institute, 2111 Wilson Boulevard, Suite 500, Arlington, VA 22201, U.S.A.

A1.3 ANSI/AHRI Standard 420-2008, *Performance Rating of Forced-Circulation Free-Delivery Unit Coolers for Refrigeration*, 2008, Air-Conditioning, Heating and Refrigeration Institute, 2111 Wilson Boulevard, Suite 500, Arlington, VA 22201, U.S.A.

A1.4 ANSI/AHRI Standard 520-2004, *Performance Rating of Positive Displacement Condensing Units*, 2004, Air-Conditioning, Heating and Refrigeration Institute, 2111 Wilson Boulevard, Suite 500, Arlington, VA 22201, U.S.A.

A1.5 ANSI/AHRI Standard 1201 (SI)-2010, *Performance Rating of Commercial Refrigerated Display Merchandisers and Storage Cabinets*, 2010, Air-Conditioning, Heating and Refrigeration Institute, 2111 Wilson Boulevard, Suite 500, Arlington, VA 22201, U.S.A.

A1.6 ANSI/ASHRAE 23.1-2010, *Methods of Testing for Rating Positive Displacement Refrigerant Compressors and Condensing Units That Operate at Subcritical Temperatures*, 2010, American Society of Heating, Refrigerating, and Air-Conditioning Engineers, Inc., 1791 Tullie Circle N.E., Atlanta, GA 30329, U.S.A.

A1.7 ANSI/ASHRAE 116-2010, *Methods of Testing For Rating Seasonal Efficiency of Unitary Air Conditioners and Heat Pumps*, 2010, American Society of Heating, Refrigerating, and Air-Conditioning Engineers, Inc., 1791 Tullie Circle N.E., Atlanta, GA 30329, U.S.A.

A1.8 ANSI/ASHRAE Standard 41.4-1996 (RA 2006), *Standard Method for Measurement of Proportion of Lubricant in Liquid Refrigerant*, 2006, American Society of Heating, Refrigerating, and Air-Conditioning Engineers, Inc., 1791 Tullie Circle, N.E., Atlanta, GA 30329, U.S.A.

A1.9 ASHRAE Standard 37-2009, *Methods of Testing for Rating Unitary Air-Conditioning and Heat Pump Equipment*, 2009, American Society of Heating, Refrigerating, and Air-Conditioning Engineers, Inc., 1791 Tullie Circle N.E., Atlanta, GA 30329, U.S.A.

A1.10 ANSI/ASHRAE Standard 41.1-1986 (RA 2006), *Standard Method For Temperature Measurement*, 2006, American Society of Heating, Refrigerating, and Air-Conditioning Engineers, Inc., 1791 Tullie Circle, N.E., Atlanta, GA 30329, U.S.A.

A1.11 ANSI/ASHRAE Standard 41.3-1989, *Standard Method For Pressure Measurement*, 1989, American Society of Heating, Refrigerating, and Air-Conditioning Engineers, Inc., 1791 Tullie Circle, N.E., Atlanta, GA 30329, U.S.A.

A1.12 ANSI/ASHRAE Standard 41.10-2008, *Standard Methods for Volatile-Refrigerant Mass Flow Measurements Using Flowmeters*, 2008, American Society of Heating, Refrigerating, and Air-Conditioning Engineers, Inc., 1791 Tullie Circle, N.E., Atlanta, GA 30329, U.S.A.

A1.13 ANSI/ASHRAE Standard 41.2.1987 (RA 92), *Standard methods for laboratory air-flow measurement*, 1992, American Society of Heating, Refrigerating, and Air-Conditioning Engineers, Inc., 1791 Tullie Circle, N.E., Atlanta, GA 30329, U.S.A.

A1.14 *ASHRAE Terminology*, <https://www.ashrae.org/resources--publications/free-resources/ashrae-terminology>, 2014, American Society of Heating, Refrigerating and Air-Conditioning Engineers, Inc., 1791 Tullie Circle, N.E., Atlanta, GA 30329, U.S.A.

A1.15 TYM3 Weather Data for Kansas City, Missouri, *National Solar Radiation Database*, http://rredc.nrel.gov/solar/old_data/nsrdb/1991-2005/tmy3/by_state_and_city.html#O.

APPENDIX B. REFERENCES – INFORMATIVE

None.

APPENDIX C. METHODS OF TESTING WALK-IN COOLER AND FREEZER SYSTEMS – NORMATIVE

C1. Purpose. The purpose of this appendix is to provide a method of testing for walk-in cooler and freezer systems that have either matched or rated separately, Unit Coolers and condensing units

C2. Scope. These methods of testing apply to walk-in cooler and freezer systems that have either matched or rated separately, factory-made, forced circulation, free-delivery Unit Coolers and factory-made electric motor driven, single and variable capacity Positive Displacement Condensing Units

C2.1 Exclusions. These methods of testing do not apply to:

C2.1.1 Air-conditioning units used primarily for comfort cooling for which testing methods are given in other standards.

C2.1.2 Unit Coolers installed in or connected to ductwork

C2.1.3 Parallel rack refrigeration systems

C2.1.4 Field testing of Unit Coolers

C3. Measurements. All the measurements associated with the test shall be in accordance with AHRI Standard 1250 Table 1 for required instrumentation accuracy.

C3.1 Temperature Measurements.

C3.1.1 Temperature measurements shall be made in accordance with ANSI/ASHRAE Standard 41.1.

C3.1.2 Air wet-bulb and dry-bulb temperatures entering the Unit Cooler shall be measured based on the airflow area at the point of measurement. One measuring station is required for each 0.19 m² of the first 0.93 m² of airflow area and one additional measuring station is required for each 0.27 m² of airflow area above 0.93 m². A minimum of two stations shall be used and the number of measuring stations shall be rounded up to the next whole number.

C3.1.3 The airflow area shall be divided into the required number of equal area rectangles with aspect ratios no greater than 2 to 1. Additional measuring stations may be necessary to meet this requirement. The measuring stations shall be located at the geometric center of each rectangle.

C3.1.4 The maximum allowable deviation between any two air temperature measurement stations shall be 1.1 °C.

C3.1.5 If sampling tubes are used, each tube opening may be considered a temperature measuring station provided the openings are uniformly spaced along the tube, the airflow rates entering each port are relatively uniform ($\pm 15\%$) and the arrangement of tubes complies with the location requirements of Section C3.1.3. Additionally, a one time temperature traverse shall be made over the measurement surface, prior to the test to assess the temperature variation and ensure it complies with the allowable deviation specified in Section C3.1.4. (Refer to ANSI/ASHRAE Standard 41.1 for more information and diagrams).

C3.1.6 Refrigerant temperatures entering and leaving the Unit Cooler shall be measured by sheathed temperature sensors immersed in flowing refrigerant or by a temperature measuring instrument placed in a thermometer well and inserted into the refrigerant stream. These wells shall be filled with non-solidifying, thermal conducting liquid or paste to ensure the temperature sensing instrument is exposed to a representative temperature. The entering temperature of the refrigerant shall be measured within six pipe diameters upstream of the control device.

C3.2 *Pressure Measurements.* Connections for pressure measurements shall be smooth and flush within the pipe wall and shall be located not less than six pipe diameters downstream from fittings, bends, or obstructions. (Refer to ANSI/ASHRAE Standard 41.3 for more information and diagrams).

C3.3 *Refrigerant Properties Measurement.*

C3.3.1 With the equipment operating at the desired test conditions, the temperature and pressure of the refrigerant leaving the Unit Cooler, entering the expansion device, and entering and leaving the compressor shall be measured. For cases where the calibrated box method is also conducted, data used to calculate capacity according to the refrigerant enthalpy method and the calibrated box method shall be collected over the same intervals.

C3.3.2 On equipment not sensitive to refrigerant charge, pressure measuring instruments may be tapped into the refrigerant lines provided that they do not affect the total charge by more than 0.5%.

C3.3.3 On equipment sensitive to refrigerant charge, a preliminary test is required prior to connecting any pressure gauges or beginning the first official test. In preparation for this preliminary test, temperature sensors shall be attached to the equipment's evaporator and condenser coils. The sensors shall be located at points that are not affected by vapor superheat or liquid subcooling. Placement near the midpoint of the coil, at a return bend, is recommended. The preliminary test shall be conducted with the requirement that the temperatures of the on-coil sensors be included with the regularly recorded data. After the preliminary test is completed, the refrigerant shall be removed from the equipment, and the needed pressure gauges shall be installed. The equipment shall be evacuated and recharged with refrigerant. The test shall then be repeated. Once steady-state operation is achieved, refrigerant shall be added or removed until, as compared to the average values from the preliminary test, the following conditions are achieved: (1) each on-coil temperature sensor indicates a reading that is within $\pm 0.3^{\circ}\text{C}$, (2) the temperatures of the refrigerant entering and leaving the compressor are within $\pm 2^{\circ}\text{C}$, and (3) the refrigerant temperature entering the expansion device is within $\pm 0.5^{\circ}\text{C}$. Once these conditions have been achieved over an interval of at least ten minutes, refrigerant charging equipment shall be removed and the first of the official tests shall be initiated.

C3.3.4 No instrumentation shall be removed, replaced, or otherwise disturbed during any portion of a complete capacity test.

C3.3.5 Temperatures and pressures of the refrigerant vapor entering and leaving the compressor shall be measured at approximately 25 cm from the compressor shell.

C3.4 *Refrigerant Flow Measurement*

C3.4.1 Refrigerant flow meters shall be installed and the flow rate of Volatile Refrigerants shall be measured in accordance with ANSI/ASHRAE Standard 41.10.

C3.4.2 The refrigerant flow rate shall be measured with an integrating type flow meter connected in the liquid line upstream of the refrigerant control device. This meter shall be sized so that its pressure drop does not exceed the vapor pressure change that a 2°C saturation temperature change would produce. Refrigerant flow meter is only allowed to be installed at the superheated vapor line as second independent measurement when the refrigerant enthalpy method is used. In such a case, refrigerant vapor must be superheated both upstream and downstream of the meter to ensure the vapor remains single phase.

C3.4.3 Flow meters shall be installed with at least ten pipe diameters upstream and five diameters downstream of the meter, in straight pipe free of valves and fittings, or in accordance with the manufacturer's instructions.

C3.4.4 A direct reading mass-flow-rate measuring device, such as a coriolis meter, is the preferred instrument for measuring the refrigerant flow rate. Other flow meters that demonstrate the capability to measure flow rate with the specified accuracy are also acceptable.

C3.4.5 Temperature and pressure measuring instruments and a sight glass shall be installed immediately downstream of the meter to determine if the refrigerant liquid is adequately subcooled. Subcooling of 2°C and the absence of any vapor bubbles in the liquid are considered adequate. It is recommended that the meter be

installed at the bottom of a vertical downward loop in the liquid line to take advantage of the static head of liquid thus provided.

C3.5 Unit Cooler Fan Power Measurement. The following shall be measured and recorded during a compressor-off cycle fan power test.

| | |
|------------------------------|--|
| $\dot{E}F_{\text{comp,off}}$ | Total electrical power input to fan motor(s) of Unit Cooler, W |
| FS | Fan speed (s), rpm |
| N | Number of motors |
| P_b | Barometric pressure, kPa |
| T_{db} | Dry-bulb temperature of air at inlet, °C |
| T_{wb} | Wet-bulb temperature of air at inlet, °C |
| V | Voltage of each phase, V |

For a given motor winding configuration, the total power input shall be measured at the highest nameplated voltage. For three-phase power, voltage imbalance shall be no more than 2 % from phase to phase

C3.6 Recording and Measurement Intervals. For steady state testing, data shall be recorded after the unit to be tested approached its steady state conditions for at least 30 minutes at the specified test conditions defined in Section 5.1. The unit shall be maintaining its steady state throughout the entire recording period. Measurement intervals shall be in accordance with Table C1.

C3.6.1 The steady state operation is defined as follows. The variations of the air-side temperatures are within $\pm 1\text{K}$ of the average values. The saturated refrigerant temperatures corresponding to the measured refrigerant-side pressures have maximum variations of $\pm 1.7\text{K}$ of the average values. The refrigerant mass flow rates' fluctuations are within 2% of the readings.

| Test Parameter | Minimum Data Collection Rate, Test Readings per Hour | Minimum Number of Test Readings per Test Run ³ |
|---|--|---|
| Temperature | 30 | 15 |
| Pressure | 30 | 15 |
| Refrigerant mass flow rate | 30 | 15 |
| Test room barometric pressure | 1 | 1 |
| Fan speed(s) | 1 | 1 |
| Total electrical power input to fan motor(s) | 3 | 2 |
| Total electrical power input to heater and auxiliary equipment ² | 3 | 2 |
| Notes: | | |
| 1. Once the system approaches steady state condition, data shall be recorded. | | |
| 2. For calibrated box only (Method 2) | | |
| 3. Duration of recording data shall be a minimum of 30 minutes | | |

C4. *Walk-in system General Data.* Refer to AHRI Standard 420 and ANSI/AHRI Standard 520 for the information that shall be recorded, where applicable, regarding the system physic data and test information.

C5. *Methods of Testing for Walk-in Cooler and Freezer Systems that have Matched Unit Coolers and Condensing Units or Unit Coolers Rated Separately.* See Section C13 for details on testing Unit Coolers rated separately. See Section C12 for method of testing condensing units rated separately.

C5.1 *The Gross Total Refrigeration Capacity of Unit Coolers* from steady state test shall be determined by either one of the following methods.

C5.1.1 *Method 1, DX Dual Instrumentation (Refrigerant Enthalpy Method).* The Refrigeration Capacity shall be determined by measuring the enthalpy change and the mass flow rate of the refrigerant across the Unit Cooler using two independent measuring systems.

C5.1.2 *Method 2, DX Calibrated Box.* The Refrigeration Capacity shall be determined concurrently by measuring the enthalpy change and the mass flow rate of the refrigerant across the Unit Cooler and the heat input to the calibrated box.

C5.2 Upon the completion of the steady state test, an off-cycle evaporator fan power test shall be conducted to measure the evaporator fan power consumption during a compressor-off period in accordance with Section C10 of this standard.

C5.3 Upon the completion of the steady state test for walk-in freezer systems, a mandatory defrost test shall be conducted to establish the energy input for a defrost cycle. An optional defrost test to establish the energy input for a defrost cycle and the time between defrost intervals for a frosted load condition and an additional optional test to establish credit for an adaptive or demand defrost system may be elected after the mandatory defrost test.

C6. *Test Chambers Requirements.*

C6.1 The Unit Cooler and the condensing unit shall be installed in separate environment chambers with sufficient size to avoid airflow restrictions or recirculation such that:

C6.1.1 No obstacle is positioned within a distance of $2\sqrt{AB}$.

From the discharge of the Unit Cooler and the condensing unit, where A and B are the air inlet dimensions, mm, per fan section of the Unit Cooler and the condensing unit.

C6.1.2 All other distances correspond to the minimum requirements of the installation instructions provided by the manufacturer.

C6.1.3 The minimum volume, m³, of the test chamber shall be 1200 % of the airflow rate, m³/s produced by the Unit Cooler together with all auxiliary air moving devices that operate simultaneously with the Unit Cooler.

C6.2 Both environmental chambers shall be equipped with essential air handling units and controllers to process and maintain the enclosed air to any required test conditions.

C7. *General Test Conditions and Data Recording.*

C7.1 Refer to the standard rating conditions for a particular application listed in Section 5 of this standard. Test acceptance criteria listed in Table 2 in section 4 of this standard apply to both methods of test.

C7.2 Data that need to be recorded during the test are listed in Table C2.

| Table C2. Data To be Recorded | | | |
|--|--------|-----------------------------|-----------------------|
| | Units | Refrigerant Enthalpy Method | Calibrated Box Method |
| Date | | X | X |
| Observer(s) | | X | X |
| Barometric pressure | kPa | X | X |
| Times | | X | X |
| Power input to condensing unit | W | X | X |
| Power input to Unit Cooler fan(s) | W | X | X |
| Applied Voltage to condensing unit | volts | X | X |
| Applied Voltage to Unit Cooler fan | volts | X | X |
| Total electrical power input to heater and auxiliary equipment | W | | X |
| Frequency | Hz | X | X |
| Fan speed(s) if adjustable | rpm | X | X |
| Air inlet relative humidity | | X | X |
| Average dry-bulb temperature of air within the calibrated box | °C | | X |
| Average dry-bulb temperature of air within the temperature controlled enclosure | °C | | X |
| Dry-bulb temperatures of air entering Unit Cooler and condensing unit | °C | X | X |
| Wet-bulb temperatures of air entering Unit Cooler and condensing unit | °C | X | X |
| Dry-bulb temperatures of air leaving Unit Cooler and condensing unit | °C | X | |
| Wet-bulb temperatures of air leaving Unit Cooler and condensing unit | °C | X | |
| Condensing pressure or temperature | kPa/°C | X | X |
| Evaporator pressure or temperature | kPa/°C | X | X |
| Pressure of subcooled refrigerant liquid entering the expansion valve | kPa | X | X |
| Pressure of superheated refrigerant vapor leaving the Unit Cooler | kPa | X | X |
| Pressure of refrigerant vapor at compressor suction | kPa | X | X |
| Pressure of refrigerant vapor at compressor discharge | kPa | X | X |
| Temperature of subcooled refrigerant liquid entering the expansion | °C | X | X |
| Temperature of superheated refrigerant vapor leaving the Unit Cooler | °C | X | X |
| Temperature of refrigerant vapor at compressor suction | °C | X | X |
| Temperature of refrigerant vapor at compressor discharge | °C | X | X |
| Mass flow rate of subcooled refrigerant liquid through M1 | g/s | X | X |
| Mass flow rate of subcooled refrigerant liquid through M2 or superheated refrigerant vapor through M2ALT | g/s | X | X |

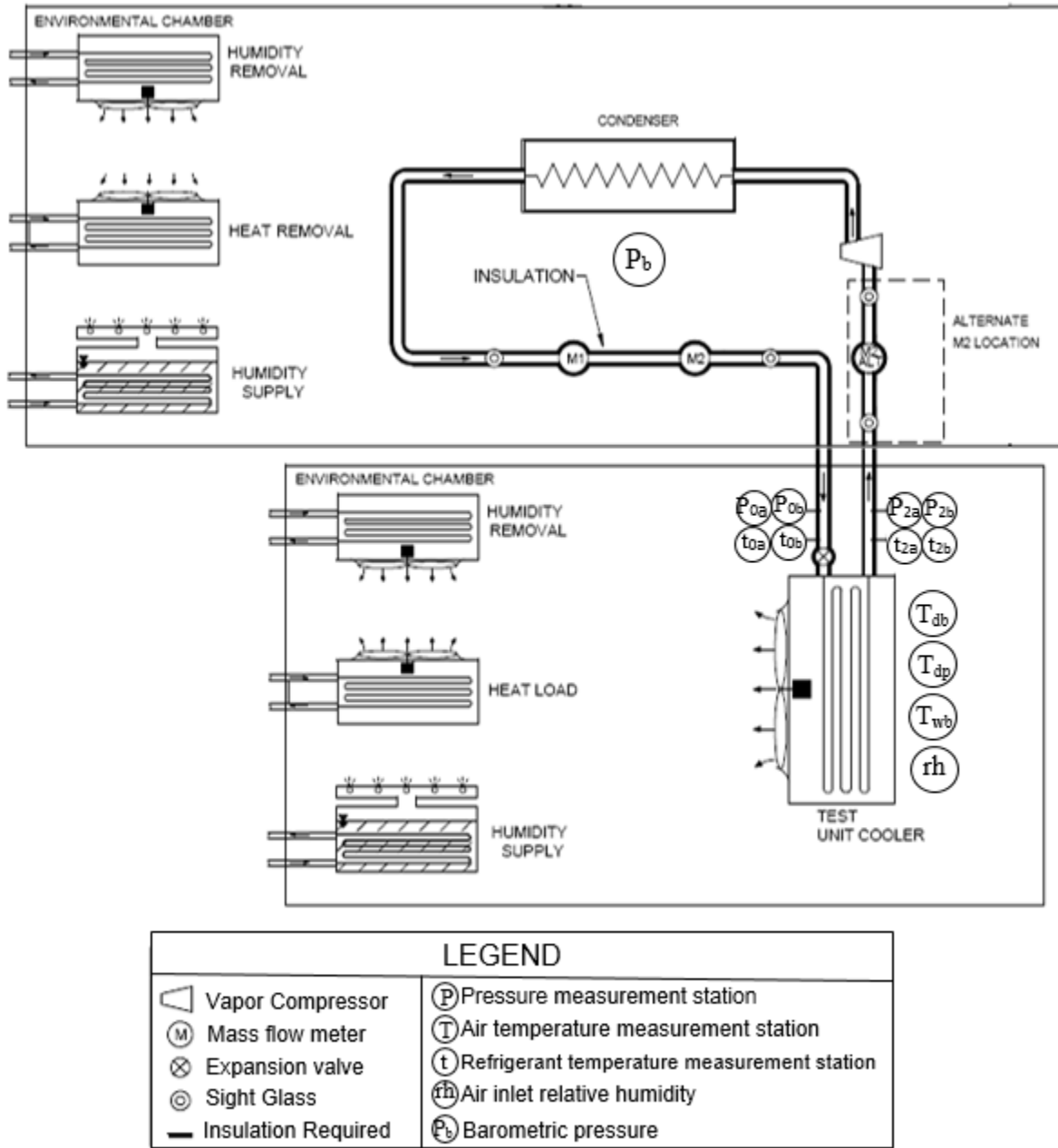

Figure C1. Method 1: DX - Dual Instrumentation

which the refrigerant charge is not critical and where normal installation procedures involve the field connection of refrigerant lines. This method shall not be used for tests in which the refrigerant liquid leaving the flow meter is subcooled less than 2°C or for tests in which any instantaneous measurement of the superheat of the vapor leaving the evaporator coil is less than 3°C. If supplementary cooling in the liquid line is artificially introduced to ensure enough subcooling, the added cooling capacity shall be measured and deducted from the Gross Refrigeration Capacity calculated in Section C8.5.2.

C8.2 *Measurements.* Refer to Section C3 for requirements of air-side and refrigerant-side measurements

C8.3 *Test Setup and Procedure.* Refer to Section C6, C7 and Figure C1 for specific test setup. The condensing unit and the Unit Cooler shall be connected by pipes with manufacturer's specified size. The pipe lines shall be insulated with a minimum total thermal resistance equivalent to ½" thick insulation having a flat-surface R-Value of 0.65 K•m²/W per inch or greater. Flow meters need not be insulated but must not be in contact with the floor. The lengths of each of the connected liquid line and suction line shall be 7.5 meters, not including the requisite flow meters. Of this length, no more than 15 feet shall be in the conditioned space. In the case that there are multiple branches of piping, the maximum length of piping applies to each branch individually as opposed to the total length of the piping.

C8.4 *Data to be Measured and Recorded.* Refer to Table C2 in Section C7.2 for the required data that need to be measured and recorded.

C8.5 *Refrigeration Capacity Calculation.*

C8.5.1 The refrigerant-side gross capacities by independent measurement are calculated by

$$\dot{Q}_{\text{ref},1} = \dot{m}_{\text{ref},1} \cdot (h_{\text{out}} - h_{\text{in}}) \quad \text{C1}$$

$$\dot{Q}_{\text{ref},2} = \dot{m}_{\text{ref},2} \cdot (h_{\text{out}} - h_{\text{in}}) \quad \text{C2}$$

C8.5.2 Gross Refrigeration Capacity is calculated by

$$\dot{Q}_{\text{ref}} = \frac{\dot{Q}_{\text{ref},1} + \dot{Q}_{\text{ref},2}}{2} \quad \text{C3}$$

C8.5.3 Allowable Cooling Capacity heat balance

$$-5\% \leq \frac{\dot{Q}_{\text{ref},1} - \dot{Q}_{\text{ref},2}}{\dot{Q}_{\text{ref}}} \times 100\% \leq 5\% \quad \text{C4}$$

C8.5.4 The Net Refrigeration Capacity is calculated by

$$\dot{q}_{\text{ss}} = \dot{Q}_{\text{ref}} - \dot{E}F_{\text{comp,on}} \quad \text{C5}$$

C9. *DX Calibrated Box Test Procedure (Method 2)*

C9.1 *Measurements.* Refer to Section C3 for requirements of air-side and refrigerant-side measurements.

C9.2 *Test Setup and Procedure.* Refer to Sections C6, C7 and Figure C2 for specific test setup. The condensing unit and the Unit Cooler shall be connected by pipes with manufacturer's specified size. The pipe lines shall be insulated with a minimum total thermal resistance equivalent to ½" thick insulation having a flat-surface R-Value of 3.7 ft²•°F•hr/Btu per inch or greater. Flow meters need not be insulated but must not be in contact with the floor. The lengths of each of the connected liquid line and suction line shall be 25 feet, not including the requisite flow meters. Of this length, no more than 15 feet shall be in the conditioned space. In the case that there are multiple branches of piping, the maximum length of piping applies to each branch individually as opposed to the total length of the piping.

C9.2.1 Apparatus Setup for Calibrated Box Calibration and Test

C9.2.1.1 The calibrated box shall be installed in a temperature controlled enclosure in which the temperature can be maintained at a constant level.

C9.2.1.2 The temperature controlled enclosure shall be of a size that will provide clearances of not less than 457 mm at all sides, top and bottom, except that clearance of any one surface may be reduced to not less than 140 mm.

C9.2.1.3 In no case shall the heat leakage of the calibrated box exceed 30 % of the Gross Total Cooling Effect of the Unit Cooler under test. The ability to maintain a low temperature in the temperature controlled enclosure will reduce the heat leakage into the calibrated box and may extend its application range.

C9.2.1.4 Refrigerant lines within the calibrated box shall be well insulated to avoid appreciable heat loss or gain.

C9.2.1.5 Instruments for measuring the temperature around the outside of the calibrated box shall be located at the center of each wall, ceiling, and floor at a distance of 150 mm from the calibrated box. Exception: in the case where a clearance around the outside of the calibrated box, as indicated above, is reduced to less than 457 mm, the number of temperature measuring devices on the outside of that surface shall be increased to six, which shall be treated as a single temperature to be averaged with the temperature of each of the other five surfaces. When the clearance is reduced below 305 mm (one surface only), the temperature measuring instruments shall be located midway between the outer wall of the calibrated box and the adjacent wall. The six temperature measuring instruments shall be located at the center of six rectangular sections of equal area.

C9.2.1.6 Heating means inside the calibrated box shall be shielded or installed in a manner to avoid radiation to the Unit Cooler, the temperature measuring instruments, and to the walls of the box. The heating means shall be constructed to avoid stratification of temperature, and suitable means shall be provided for distributing the temperature uniformly.

C9.2.1.7 The average air dry-bulb temperature in the calibrated box during Unit Cooler tests and calibrated box heat leakage tests shall be the average of eight temperatures measured at the corners of the box at a distance of 50 mm to 100 mm from the walls. The instruments shall be shielded from any cold or warm surfaces except that they shall not be shielded from the adjacent walls of the box. The Unit Cooler under test shall be mounted such that the temperature instruments are not in the direct air stream from the discharge of the Unit Cooler.

C9.2.2 *Calibration of the Calibrated Box.* A calibration test shall be made for the maximum and the minimum forced air movements expected in the use of the calibrated box. The calibration heat leakage shall be plotted as a straight line function of these two air quantities and the curve shall be used as calibration for the box.

C9.2.2.1 The heat input shall be adjusted to maintain an average box temperature not less than 13.8 °C above the test enclosure temperature.

C9.2.2.2 The average dry-bulb temperature inside the calibrated box shall not vary more than 0.6 °C over the course of the calibration test.

C9.2.2.3 A calibration test shall be the average of eleven consecutive hourly readings when the box has reached a steady-state temperature condition.

C9.2.2.4 The box temperature shall be the average of all readings after a steady-state temperature condition has been reached.

C9.2.2.5 The calibrated box has reached a steady-state temperature condition when:

1. The average box temperature is not less than 13.8 °C above the test enclosure temperature.
2. Temperature variations do not exceed 2.8 °C between temperature measuring stations.
3. Temperatures do not vary by more than 1.1 °C at any one temperature- measuring station.

C9.3 *Data to be Measured and Recorded.* Refer to Table C2 in Section C7.2 for the required data that need to be measured and recorded.

C9.4 *Refrigeration Capacity Calculation.*

C9.4.1 The heat leakage coefficient of the calibrated box is calculated by:

$$K_{cb} = \frac{\dot{E}_c}{T_{en} - T_{cb}} \quad C6$$

C9.4.2 For each Dry Rating Condition, calculate the air-side Gross Total Refrigeration Capacity:

$$\dot{Q}_{air} = K_{cb} \cdot (T_{en} - T_{cb}) + \dot{E}_c + EF_{comp,on} \quad C7$$

C9.4.3 For each Dry Rating Condition, calculate the refrigerant-side Gross Total Refrigeration Capacity:

$$\dot{Q}_{ref} = \dot{m}_{ref} \cdot (h_{out} - h_{in}) \quad C8$$

C9.4.4 Gross Total Refrigeration Capacity:

$$\dot{Q}_t = \frac{\dot{Q}_{air} + \dot{Q}_{ref}}{2} \quad C9$$

C9.4.5 Allowable Refrigeration Capacity heat balance

$$-5\% \leq \frac{\dot{Q}_{air} - \dot{Q}_{ref}}{\dot{Q}_t} \times 100\% \leq 5\% \quad C10$$

C10. Off-cycle Evaporator Fan Test. Upon the completion of the steady state test for walk-in systems, the compressors of the walk-in systems shall be turned off. The Unit Coolers fans' power consumption shall be measured in accordance with the requirements in Section C 3.5. Off-cycle fan power shall be equal to on-cycle fan power unless evaporator fans are controlled by a qualifying control. Qualifying evaporator fan controls shall have a user adjustable method of destratifying air during the off-cycle including but not limited to: adjustable fan speed control or periodic "stir cycles." Controls shall be adjusted so that the greater of a 50% duty cycle or the manufacturer default is used for measuring off-cycle fan energy. For variable speed controls, the greater of 50% fan speed or the manufacturer's default fan speed shall be used for measuring off-cycle fan energy. When a cyclic control is used, at least three full "stir cycles" are measured.

C11. Defrost Test (Freezer Only). The defrost test consists of a mandatory test to establish the energy input for a defrost cycle for a dry coil condition, an optional test to establish the energy input for a defrost cycle and the time between defrost intervals for a frosted load condition, and an additional optional test to establish credit for an adaptive or demand defrost system. Refer to the standard rating conditions for defrost test conditions listed in Section 5 of this standard.

C11.1 Dry Coil Condition (Mandatory Test). During the test, no adjustments are to be made to the defrost settings. Following a defrost, the Unit Cooler shall be operated at the dry coil conditions specified in Section 5 until stable, and then a defrost shall be initiated either through manual override or by the automatic controls. The energy input and

duration of the dry coil condition (DF_d in W-h) shall be measured from the time the refrigeration system stops until it restarts again.

C11.2 *Frosted Load Condition (Calculation Methodology and Optional Test).*

C11.2.1 In lieu of testing, the frosted load energy input (DF_f in W-h) shall be the product of 1.05 times the energy input of the dry coil condition (DF_d in W-h) obtained from the test conducted in C11.1. The number of defrosts per day (N_{DF}) shall be equal to the defrost frequency recommended in the installation instructions for the unit; if no defrost frequency is specified, the number of defrosts per day shall be set to 4.

C11.2.2 *Optional Test.* Upon completion of the test conducted in C11.1, the room conditions shall then be set to the frost load conditions in C11.2.2.1, the defrost frequency set to either the recommendation in the installation instructions or if not specified, set to 4 defrosts per day (6 hour interval) and the unit operated until the unit self-initiates a defrost cycle. The energy input and duration of the frosted load condition (DF_f in W-h) shall be measured from the time the refrigeration system stops until it restarts again. The drain water shall be collected, weighed (m_w) and the temperature (T_w) recorded. This would be used to reduce the defrost energy contribution to the box load calculation. The total energy would still be used in the power side of the AWEF calculation.

C11.2.2.1 *Frost Load Condition.* The frost load shall occur through the infiltration of air at 24°C dry-bulb / 18°C wet-bulb into the walk-in freezer. Infiltration shall arise from the introduction of a constant rate of air flow at the above stated conditions, into the box during the test period. The flow rate shall be determined by the following equation, and be measured in accordance with ASHRAE Standard 41.2.

$$\dot{V}_{\text{air}} = k_{13} \cdot \dot{q}_{\text{ss}} (35) + k_{14} \text{ for the case that the condensing units is located outdoor, or} \quad \text{C11}$$

$$\dot{V}_{\text{air}} = k_{13} \cdot \dot{q}_{\text{ss}} (32) + k_{14} \text{ for the case that condensing unit is located within a} \\ \text{conditioned space.} \quad \text{C12}$$

Where:

$$\begin{aligned} \dot{V}_{\text{air}} &= \text{Infiltration air volumetric flow rate, m}^3/\text{s} \\ k_{13} &= 1.6 \times 10^{-7} \text{ m}^3/\text{s-W} \\ k_{14} &= 1.6 \times 10^{-7} \text{ m}^3/\text{s-W} \end{aligned}$$

C11.3 *Adaptive Defrost (Optional Test).*

C11.3.1 Method one: If the system has an adaptive or demand defrost system, an optional test can be run at the dry coil conditions to establish the maximum time interval allowed between dry coil defrosts and at the frosted load condition in Section C11.2.2.1 to establish the maximum time interval allowed between frosted coil defrosts. The defrost frequency, if specified, shall be set to the recommendation in the installation instructions. The unit shall be operated until one of the following occurs: 1) the unit self-initiates a defrost cycle, 2) 12 hours of elapsed run time is reached, or 3) the Unit Cooler leaving vapor pressure decreases the equivalent of 2.8°C of saturation temperature drop to indicate a sufficiently blocked or frosted coil. The measured time between successive defrosts for dry coil condition shall be averaged with the time between successive defrosts for the frosted load condition, and this average time interval used to calculate the number of defrost per day (N_{DF}).

C11.3.2 Method two: If the system has an adaptive or demand defrost system, the number of defrosts per day (N_{DF}) may be calculated by taking the average of 1 and the number of defrosts per day that would occur under frosted load conditions in Section C11.2.

C11.4 *Defrost Adequacy Test.* The test shall verify that any defrost setting and arrangement is adequate to melt all frost and ice from the coil and drain it out of the Walk-In. At the conclusion of the frosted load defrost test, the Unit Cooler shall continue to operate at the same stabilized condition for a period of not less than two additional frosted load defrost cycles, or 24 hours, whichever comes first. Upon conclusion of this test, all drain pans, fans and coils shall be checked for residual ice or frost that might continue to accumulate over time. If ice or frost is found, then an additional

48-hour test period shall be performed without changing the test or defrost settings. At the conclusion of the 48-hour test period, another check for residual ice or frost shall be conducted. If the accumulation has stabilized and not increased, then the test data are acceptable. If the ice or frost accumulation has increased then the test is unacceptable for inclusion in the test performance data and this occurrence shall be reported. For Unit Coolers utilizing electric defrost, the average of the dry coil and frost load defrost energy shall be used for calculating the value of DF, the daily average defrost energy required for the refrigeration system.

$$DF = \frac{DF_d + DF_f}{2} \cdot N_{DF} \quad C13$$

For Unit Coolers utilizing hot gas defrost and connected to a multiplex system, DF is equal to zero. For Unit Coolers utilizing hot gas defrost and connected to a dedicated condensing system, DF is calculated as follows.

$$DF = 0.5 \cdot Q_{DF} \cdot N_{DF} \quad C14$$

For Unit Coolers utilizing electric defrost, the daily contribution of the load attributed to defrost shall be calculated using an average of the dry coil and net frost load defrost energy.

$$Q_{DF} = \frac{DF_d + \{DF_f \cdot m_w [c_{pi}(0 + 5.6) + H_{fus} + c_{pw}(T_w - 0)]\}}{2} \cdot N_{DF} \quad C15$$

If the optional frost load defrost test is not performed for units utilizing electric defrost, Q_{DF} shall be calculated as follows.

$$Q_{DF} = 0.95 \cdot DF \quad C16$$

For Unit Coolers utilizing hot gas defrost, the daily contribution of the load attributed to defrost shall be calculated utilizing the Unit Cooler's capacity. The number of defrosts per day for this calculation shall be set to the number recommended in the installation instructions for the unit (or if no instructions, shall be set to 4) for units without adaptive defrost and 2.5 for units with adaptive defrost.

$$Q_{DF} = 0.18 \cdot Q_{ref} \cdot N_{DF} \quad C17$$

Where

Q_{ref} = Gross Refrigeration Capacity as measured at the high ambient condition, W

Consequently, the defrost power consumption contributed to the total system power consumption and to the box load are calculated by the following equations respectively.

$$DF = \frac{DF}{24} \quad C18$$

$$\dot{Q}_{DF} = \frac{Q_{DF}}{24} \quad C19$$

C12. *Method of Testing Condensing Units for Walk-in Cooler and Freezer Systems Where the Condensing Unit is Rated Separately.* The purpose of this section is to provide a testing method for stand-alone condensing units that provide sufficient data to allow for Standard Rating performance and AWEF determination for a reference Unit Cooler. The reference Unit Cooler shall have the following values:

| Table C3. Unit Cooler Nominal Values for Condensing Unit Energy Calculations | | |
|---|-------------------------------------|---------|
| Description | Cooler | Freezer |
| Saturated Suction Temperature, °C | -4 | -29 |
| On-cycle evaporator fan power, per W of gross capacity at ambient condition, W/W | 0.055 | 0.055 |
| Off-cycle evaporator fan power, W | 0.2 x on-cycle evaporator fan power | |
| Electric defrost energy per cycle, per W of gross capacity, W-h/cycle per W | 0 | 0.41 |
| Number of cycles per day | N/A | 4 |
| Daily electric defrost contribution, W-h | 0.95 x daily defrost energy use | |

The suction condition test points in Tables 11, 12, 13 and 14 in Section 5.1 of this standard must be run and the results reported, depending upon applications. The AWEF shall be calculated as described in Section 7.10. The condensing units shall have proper refrigerant charge to meet the subcooling requirement according to the equipment specification during the test period. The specified amount of subcooling shall be reported as a part of the test results. Refer to ASHRAE Standard 23 for the test methods, requirements and procedures.

C13. Method of Testing Unit Coolers for Walk-In Cooler and Freezer Systems Where the Unit Cooler is Rated Separately. The purpose of this section is to provide a testing method for stand-alone Unit Coolers that provide sufficient data to allow for standard rating performance and AWEF determination when combined with an unknown refrigeration system. These Unit Coolers are sold separately and may be combined with a remote condensing unit or a Parallel Rack System. The AWEF shall be calculated as described in Section 7.9.

All saturation condition test points in Tables 15 and 16 of Section 5.1 in this standard must be run and the results reported, depending upon applications.

APPENDIX D. WEATHER DATA IN REGION IV – NORMATIVE

D.1 The temperature bins and corresponding bin hours applied in the AWEF shall be based on the TMY-3 weather data of Kansas City, Missouri, which corresponds closely to the 'use cycle' climate parameters prescribed in other DOE appliance standards (10 CFR 430.23). The temperature and bin hours are listed in Table D1.

| Table D1. Bin Temperatures and Corresponding Bin hours for AWEF Calculation | |
|--|--------------|
| Bin Temperature, °C | Bin hours, h |
| 38 | 9 |
| 35 | 74 |
| 32 | 257 |
| 29 | 416 |
| 26 | 630 |
| 23 | 898 |
| 20 | 737 |
| 17 | 943 |
| 14 | 628 |
| 11 | 590 |
| 8 | 677 |
| 5 | 576 |
| 2 | 646 |
| -1 | 534 |
| -4 | 322 |
| -7 | 305 |
| -10 | 246 |
| -13 | 189 |
| -16 | 78 |
| -19 | 5 |