



Final Report

AHRI Report No. 8017

Investigation of Energy Produced by Potential Ignition Sources in Residential Application

Final Report

Date Published – November 3, 2017

Dennis K. Kim and Peter B. Sunderland

Department of Fire Protection Engineering,
University of Maryland
College Park, Maryland

Prepared for



AIR-CONDITIONING, HEATING AND REFRIGERATION INSTITUTE
2111 Wilson Boulevard, Suite 500, Arlington, Virginia 22201-3001

DISCLAIMER

This report was prepared as an account of work sponsored by the Air-Conditioning, Heating, and Refrigeration Institute (AHRI). Neither AHRI, its research program financial supporters, or any agency thereof, nor any of their employees, contractors, subcontractors or employees thereof - makes any warranty, expressed or implied; assumes any legal liability or responsibility for the accuracy, completeness, any third party's use of, or the results of such use of any information, apparatus, product, or process disclosed in this report; or represents that its use would not infringe privately owned rights. Reference herein to any specific commercial product, process, or service by trade name, trademark, manufacturer, or otherwise, does not necessarily constitute nor imply its endorsement, recommendation, or favoring by AHRI, its sponsors, or any agency thereof or their contractors or subcontractors. The views and opinions of authors expressed herein do not necessarily state or reflect those of AHRI, its program sponsors, or any agency thereof.

© 2017 AHRI

Contents

1	Executive Summary	4
2	Introduction	5
3	Apparatus and Test Procedures	12
4	Hot Wire Results	21
5	Safety Match Results.....	26
6	Lighter Flame Insertion Results	28
7	Leak Impinging on Candle Results	29
8	Cigarette Insertion Results	34
9	Barbeque Lighter Results.....	36
10	Plug and Receptacle Results.....	38
11	Light Switch Results	39
12	Hand Mixer Results.....	41
13	Cordless Drill Results	43
14	Friction Sparks Results.....	44
15	Hair Dryer Results.....	46
16	Toaster Results	48
17	Hot Plate Insertion Results	50
18	Space Heater Insertion Results	52
19	Conclusions	54
20	References	55
21	Appendix I. Literature Review	57
22	Appendix II. Past Test Summary	71

1 Executive Summary

An international drive toward sustainability of refrigeration systems will require the adoption of low global warming potential (GWP) refrigerants. Most of these are mildly flammable. Low-GWP refrigerants are generally well characterized in terms of their lower flammability limits, heats of combustion, and flame speeds. However, they are poorly understood in terms of their susceptibility to ignition from sources commonly encountered in residential and industrial settings, including motors, electric arcs, hot surfaces, and open flames. This important gap in understanding is the focus of this project.

The primary objective of this project was to perform tests to determine the viability of various ignition sources to ignite A2L refrigerants in air. This is divided into three main tasks, as follows. Task 1: perform a detailed literature review of past work in this area. Task 2: develop an ignition test plan. Task 3: conduct ignition tests.

A detailed literature review of past work is presented. This reveals significant gaps in past experiments of ignition of A2L refrigerants.

Based on the literature review, 15 ignition sources were identified for consideration here. The AHRI project monitoring subcommittee selected the following refrigerants: R-32, R-452B, R-1234yf, and R-1234ze. An experimental apparatus was built, this including a windowed stainless steel chamber with dimensions of $0.3 \times 0.3 \times 0.3$ m and a volume of 27 L. Ignition tests were conducted for each ignition source and each refrigerant.

Four of the ignition sources resulted in deflagrations or localized flames in the refrigerant-air mixtures. These were: hot wire, safety match, lighter flame insertion, and leak impinging on candle, in order of decreasing ignition viability.

Among the 15 potential ignition sources, it is remarkable that 11 were unable to ignite any of the mixtures considered here. These were: cigarette insertion, barbeque lighter, plug and receptacle, light switch, hand mixer, cordless drill, friction sparks, hair dryer, toaster, hot plate insertion, and space heater insertion. The inability of so many ignition sources to ignite A2L refrigerants is attributed here to the very long quenching distances of these refrigerants when mixed with air.

Another remarkable finding is that these A2L refrigerants can act as either fuels or suppressants. For example, smoldering cigarettes were extinguished every time they encountered a stoichiometric mixture of A2L refrigerant and air.

It is recommended that the results observed here should be included in future risk assessments of A2L refrigerants. Because many potential ignition sources were found here to be unable to ignite refrigerants, the likelihood that a viable ignition source is present near a refrigerant leak is much lower than was assumed in past risk assessments. Further work also is needed to better understand why A2L refrigerants can act as either fuels or extinguishing agents for gaseous and smoldering flames, and to examine the possible effects of humidity, oil mist, and turbulence.

2 Introduction

Overview and Objectives

An international drive toward sustainability of refrigeration systems will require the adoption of low global warming potential (GWP) refrigerants. Most of these are mildly flammable, which has motivated extensive research (e.g., JSRAE, 2014; Linteris and Manion, 2015). Owing to concerns about fire safety, the first to be adopted will be A2L, or A1 but very close to the border with A2L. The A2L designation requires a lower flammability limit (LFL) above 3.5%, a heat of combustion below 19 kJ/g, and a laminar flame speed below 10 cm/s (ASHRAE 34, 2013).

Low-GWP refrigerants are generally well characterized in terms of their LFLs, heats of combustion, and flame speeds. However, they are poorly understood in terms of their susceptibility to ignition from sources commonly encountered in household and industrial settings, including motors, electric arcs, and other appliances. This important gap in understanding is the focus of this project.

The measurement of ignition limits suffers from some of the poorest repeatability in combustion research. The results can depend on seemingly negligible changes in the ignition source, the mixture conditions, or conditioning of the walls. Furthermore, absence of evidence is not evidence of absence. For example, the Bureau of Alcohol, Tobacco, Firearms and Explosives (ATF) has performed thousands of tests attempting to ignite gasoline vapors with cigarettes. None has ignited to date, but perhaps a future test will achieve ignition.

The minimum ignition energy (MIE) is known for some A2L refrigerants (ASTM E582, 2007; Takizawa et al., 2009; Minor et al., 2010). Ignition limits of refrigerants can be affected by chamber size and shape (Kataoka et al., 1996, Richard, 1998; Takahashi et al., 2003; Kul et al., 2004; Kul and Blaszkowski, 2007; Clodic and Riachi, 2009; Clodic and Jabbour, 2011).

A critical element in developing reliable risk assessments for A2L refrigerants is a detailed understanding of the required ignition source strength for the refrigerants. However, this understanding is weak. An improved understanding could improve refrigerant fault-tree analyses, such as that of Lewandowski (2012).

This project considers ways to accurately characterize potential ignition sources of A2L refrigerants. Several such sources were identified by Goetzler et al. (1998), Goetzler and Burgos (2012), and Lewandowski (2012). Unfortunately, these studies either did not consider A2L refrigerants or did not consider or fully characterize the full array of ignition sources that can be expected in residential applications. Richard et al. (2012) considered hot-plate ignition of A2L refrigerants, but was limited to 700 °C. Boussouf et al. (2014) considered hot-plate ignition, but only for R-32.

The main tasks of this project are as follows.

Task 1. Perform a detailed literature review of past work in this area. The project monitoring subcommittee requested that the literature review include 150-200 papers. Among these papers, at least 50 papers were requested from each of the three following categories: Frequency of Ignition Sources; Ignition Sources; and Ignition tests and Energy Levels. The majority of these papers were found using Web of Science, Academic Search Complete, LexisNexis Academic, or Science Direct. The PI team acquired and archived a pdf copy of each paper listed in this report.

Task 2. Develop an ignition test plan. According to the findings from Task 1, propose a detailed ignition test matrix and a detailed set of test procedures. This identified ignition sources, refrigerants and their concentrations, and chamber size. This determined the strengths of potential ignition sources near residential and commercial applications of A2L refrigerants. The selection of ignition sources emphasized those that are: able to ignite refrigerant/air mixtures; most likely to

occur near a potential refrigerant leak; and inadequately considered in past work. The selection of refrigerants considered R-32, R-452B, R-1234yf, and R-1234ze. For weak ignition sources, only stoichiometric mixtures are considered. For strong sources, lean mixtures were considered due to safety concerns.

Task 3. Conduct ignition tests. The Task 2 test plan was performed. All procedures and results were documented in detail for future reproduction. The final report was prepared.

Potential Ignition Sources

Papers on potential ignition sources were sought to create a comprehensive list of potential ignition sources that are applicable to residential and commercial air-conditioning and heat pump applications. The list of the potential ignition sources is provided in Table 2.1 along with modes of ignition and the power, energy, or temperature of the ignition sources.

Past energy level and temperature research has determined what energy levels can be expected from electrical potential ignition sources and what temperatures can be expected from hot surface ignition sources. Given this information, the ignition sources were categorized and organized for testing.

Table 2.1. Potential ignition sources. All sources are in normal operation except those noted as faulty.

	Mode of Ignition	Ignition Source	Power, Energy, or Temperature
1	Friction spark	Motor fault ^a	10 W
2	Homogeneous	Oven ^b	250 °C
3		Incandescent bulb ^c	40-100 W
4		Heat lamp ^d	250 W
5	Hot surface	Space heater ^c	650 °C
6		Hot plate ^f	200-900 °C
7		Toaster ^g	800-1500 W
8		Cigarette ^h	492 °C
9	Open flame	Cigarette Lighter ⁱ	75 W
		Candle ^j	77 W
11		Gas burner ^k	1.3-3.4 kW
12		Cell phone ^l	10-20 mJ
13		Computer mouse ^a	1 mJ
14		Electric fan ^c	50-100 W
15		Refrigerator motor ^a	1 mJ
16		Relay ^a	1 mJ
17	Spark	Vacuum cleaner ^a	1 mJ
18		Light switch ^m	600 W
19		Extension cord fault ⁿ	
20		Incandescent bulb fault ⁿ	40 J
21		Load connecting to wall receptacle ⁿ	

(a) Estimated.

(b) <http://www.geappliances.com/ge/wall-oven.htm>

- (c) <https://www.kompulsa.com/how-much-power-are-your-appliances-consuming/>
- (d) <http://www.amazon.com/Infrared-Therapy-including-LIMITED-WARRANTY/dp/B002MGVPHM>
- (e) http://www.globalspec.com/industrial-directory/high_temperature_space_heater
- (f) Boussouf et al. (2014).
- (g) <http://www.nationallibertyalliance.org/files/survival/HOW%20MANY%20WATTS%20DO%20YOU%20NEED.pdf>
- (h) Krasny (1987).
- (i) Williamson, (2003).
- (j) <https://protonsforkbreakfast.wordpress.com/2013/11/05/candle-mass-and-candle-power/>
- (k) <http://products.geappliances.com/appliance/gea-support-search-content?contentId=17971>
- (l) Bozek et al. (2006).
- (m) <http://www.homedepot.com>
- (n) Carvou et al. (2009).

Further analysis was done on several common ignition sources. Cigarettes are responsible for 9900 residential fires and 17,900 total fires annually in the U.S (Hall 2013g). For example, it was reported that a fire in a Kmart trash compactor was possibly caused by a disposed cigarette (Pocono Record 2013). The temperature of a cigarette can reach 492 °C (Krasny 1987). Krasny conducted a test that determines the temperature and heat flux of a cigarette resting on a copper plate. He also studied ignition of soft furnishings by smoldering cigarettes. Cigarettes were previously used for flammability tests with some refrigerants (Minor 2009).

A butane lighter flame was previously used for flammability tests with some refrigerants (Minor 2009). There have been very few studies regarding the ignition risk from the spark of a barbeque lighter.

The removal of a plug from an electrical receptacle often generates a spark and can be considered as a potential ignition source. A wall receptacle generally operates at 40 J (Carvou 2009).

A spark in a wall switch occurs each time the switch is used under load. Light switches are a potential spark ignition sources and they generally operate at up to 600 W.

Cordless drill motors are classified as one of three categories: brushed DC motors, brushless DC motors, and AC motors. The traditional brushed DC motor is composed of four elements: carbon brushes, a ring of magnets, an armature, and a commutator. Continuous sparks can be generated from the brushed DC motors because the brush is in constant contact with the commutator to deliver charge and this causes friction (Mahoney 2012). The cordless drill was expected to provide a shower of sparks that can potentially ignite the refrigerant/air mixture.

Friction-generated sparks have been observed to cause explosions in dust handling/processing plants.

There have been very few studies of ignition risk from a hair dryer. Hair dryers have exposed heating elements and therefore are potential ignition sources.

Toasters are potential ignition sources and they are responsible for 1390 residential fires and 2957 total fires annually in the U.S (Hall 2012). Fire risks were reported for toasters, deep-fat fryers, and electric grills (Consumer Reports 2008). Three countertop appliances have been recalled recently. One was a Proctor-Silex toaster and 482,000 units were recalled. Manchester Evening News (2011) reported that a hospital ward was evacuated after toaster fire. A toaster caught fire in Pensby in 2013 (Wirral Globe 2013).

Hot plates are responsible for 402 residential fires and 516 total fires annually in the U.S (Hall 2012). However, the leaking of fuels onto hot surfaces has caused problems in many industrial and

residential applications. The temperature of a hot plate can reach 200-900 °C (Boussouf 2014). Griffin reported an office kitchen fire that was believed to be started by a hot plate (Griffin 2008). The New York Times reported a fire caused by a malfunctioning hot plate that caused multiple fatalities. Hot plates have been used to investigate refrigerant flammability (ASTM E-659, Spatz 2008, Boussouf 2014).

Space heaters are potential ignition sources, and are responsible for 4430 residential fires and 19,940 total fires annually in the U.S. Recently, a state fire marshal issued a warning regarding the fire danger of portable space heaters (Cumberland Times-News, 2012). Space heaters are responsible for 32% of home heating fires and 79% of home heating fire deaths (NFPA, 2010).

Past Refrigerant Ignition Tests

Past ignition tests were studied to help guide the test plan for this project. A pro/con analysis was conducted to determine which test(s) best fit the project’s objectives. A total of 18 studies were included in this pro/con analysis, as summarized in Table 2.2. From this analysis, the test plan for this project was modeled after the tests performed by Goetzler et al. (1998).

Table 2.2. Pro/Con Analysis.

Study	Method	Pros	Cons
Box test of Goetzler et al. (1998).	Included a wooden box, with a plastic top for viewing. The box is filled with refrigerant, and the ignition source is activated to determine flammability	Simple Setup. Cheap and quickly replicable materials	Leakage possible. Need to develop test plan, as the one in Goetzler lacks detail
ASTM E-582	Standard for determining minimum ignition energy	Determines minimum ignition energy for mixtures.	Not alterable for the project’s purposes.
ASTM E-659	Standard for determining the autoignition temperature of chemicals	Determines autoignition temperature of liquid refrigerant. Makes use of a hot plate, an ignition source of interest. Study showed effects of lubricating oil, which is of interest.	More appropriate for ignition by heat, and not flame, spark, etc.
ASTM E-681/ASHRAE 34	Test Standard for concentration limits of flammability of chemicals	Determines flammability limits. Simple Setup. Another research team at UMD has constructed the apparatus.	Test conducted in a round flask, cannot put large ignition sources inside.
Autoignition Test Chamber, from Kim et al. (2011).	Test developed to determine autoignition of liquid fuels under different pressures	Determines autoignition of liquid fuels under different pressures.	Not alterable for the project’s purposes.
Concentration Mapping Test, from Goetzler et al. (2012).	Refrigerant is leaked into a room, and sensors are placed throughout the room	Determines concentration of refrigerant in various locations for various leak scenarios.	Full Scale test, costly. Leak test does not assure flammable mixture. Not alterable for our purposes

Full Scale Testing, from various papers.	Test of flammability using real world conditions, i.e., testing a refrigerator motor's flammability using a full size refrigerator in a full size room	Representative of scenario.	Leakage would be an issue. Requires large quantities of refrigerant to ensure LFL is reached, costly.
Gas Chromatography Test, from Clodic et al. (2009) and Mohanraj et al. (2009).	Measures concentration of gases	Measures flammability of refrigerant mixtures. UMD has a gas chromatograph	Does not use ignition. Not alterable for our purposes
Glass Box Test, from Imamura et al. (2015).	Refrigerant is leaked into the box, and then ignited	Measurement of flammability of various leak scenarios. Could be altered for our purposes	Open air, refrigerant would be a major issue.
Horizontal Tube Test, from Carlsson et al. (1996).	Ammonia is injected into the tube along with air, then the test determines ignition energy at different gap widths	Determines ignition energy at various gaps. Could be altered for our purposes	Involves construction of a large tube, may be costly. Given 150 mm diameter, large ignition sources not possible.
LFL Test, from Liu et al. (2014).	Test for flammability limits, similar to ASTM E-681/ASHRAE 34, but uses a cylinder	Determines LFL and UFL at different temperatures and pressures. Simple setup.	Not alterable for our purposes. Interior access is difficult. 5 L vessel, may not fit some ignition sources.
NMERI Explosion Sphere, from Heinonen et al. (1994).	A metal sphere used to determine flammability, similar to ASTM E-681, but uses a metal sphere	Bomb sphere used to determine flammability similarly to ASTM E-681, but a metal sphere. Might be alterable for the project's purposes.	Requires construction of a steel hemisphere, may be costly. Sphere has 250 mm diameter, would be tight fit for ignition sources/ not fit at all. No optical access.
Refrigerant Flammability test, from Gigel (2002).	Leaks refrigerant on protected/unprotected circuits and external joints to test flammability	Leak test for protected/unprotected circuits and external joints. Could be altered for our purposes.	Full scale test, costly. Leak test does not assure flammable mixture.
Tubular Flame Burner, from Dlugorski et al. (2002).	Determines the flammability properties of gases.	Measures flammability. Might be alterable for the project's purposes.	Tube diameter is only 30 mm, limiting size of ignition sources. Complicated set up.
U.S. Bureau of Mines Bomb	Determines minimum ignition energy.	Determines minimum ignition energy. Could be	Complicated set up. Difficult to install

Apparatus, from Blanc et al. (1947).		alterable for our purposes.	ignition sources. Bomb is 5 inches, requiring small ignition sources.
U.S. Bureau of Mines Tube Apparatus, from Coward et al. (1952).	Specially designed for determining limits of vapors of liquids that are sufficiently volatile at laboratory temperatures.	Can measure flammability limits of refrigerants. Could be altered for the project's purposes.	Requires custom glass tube, may be costly. Complicated set up. Tube diameter is 50 mm, requiring small ignition sources
Vertical Tube Test, from Clodic et al. (2011).	Measures burning velocity of flammable gases	Measures burning velocity. Could be altered for our purposes.	Requires purchase of 1.2 m glass tube, may be costly. Tube diameter only 44 mm. Only fit for very small ignition sources.
200 L Tube Test, from Richard (1998).	Test used to determine at what concentration of flammable gas will allow sustained ignition. Used to determine the 90° rule in ASTM E-681/ASHAE 34.	Determines flammability of refrigerants.	Not recommended for routine testing. Difficult to mount ignition sources.

Frequency of Ignition Sources

Research on frequency of ignition sources was conducted to determine how likely the potential ignition sources are to be present near residential and commercial air-conditioning and heat pump applications. This allowed the project to only test the sources that are likely to be an ignition source. Table 2.3 lists several ignition sources, along with how frequently they start fires. These values are from Hall (2013d, 2013f).

Table 2.3. Frequency of ignition sources.

Ignition Source	US Fires Annually	US Residential Fires Annually
Cigarettes	17900	9900
Range/ Cooktop	99000	8440
Electrical Arc	25060	8340
Cigarette Lighter	9600	5300
Fixed Wiring		5200
Matches	8800	5080
Space Heater	19940	4430
Oven	21600	3650
Light Bulb	4491	2790
Outlet	2590	2510
Electrical Fan	4300	1980
Toaster	2957	1390

Extension Cord	1330	1370
AC Motor	2600	1210
Refrigerator Motor	1710	790
Candles	9300	620
Heat Lamp	450	530
Hot Plate	402	516
Vacuum Cleaner	130	30

3 Apparatus and Test Procedures

The general schematic for the ignition testing is shown in Figure 3.1.

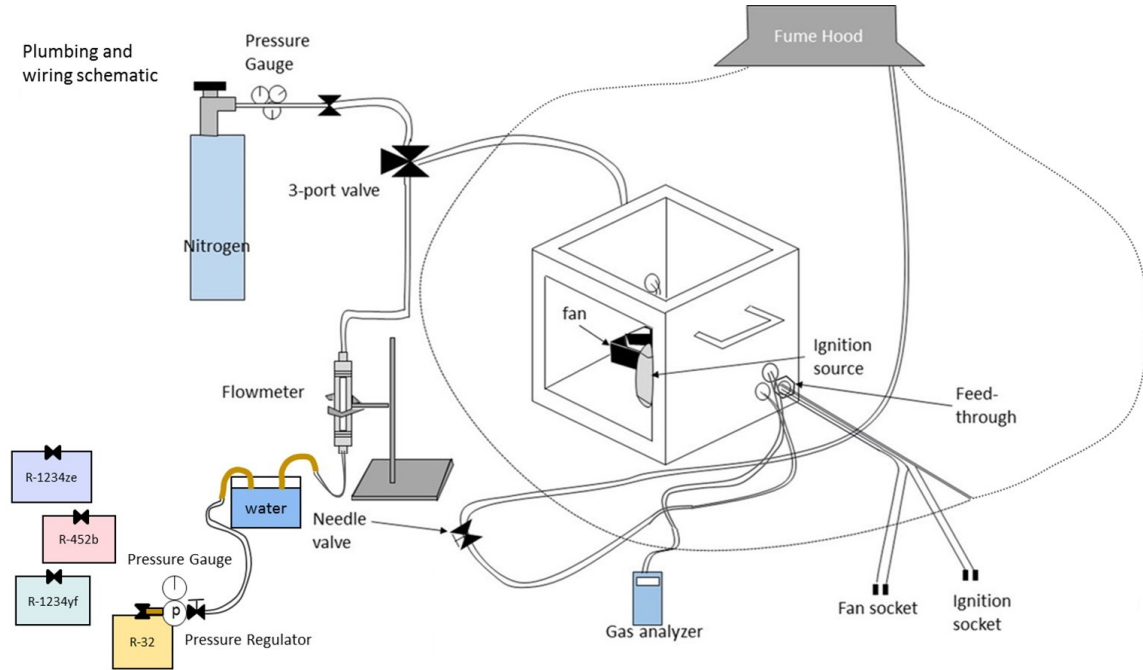

Figure 3.1. Test schematic.

The chamber had dimensions of $0.3 \times 0.3 \times 0.3$ m, with an internal volume of 27 L. This chamber is illustrated in Figure 3.2. Three of the sides and the bottom of the chamber were made of welded stainless steel. The front was clear acrylic for viewing. The top was open to allow access to the chamber, but sealed with aluminum foil and tape to mitigate leakage and pressure rise during experiments. The chamber was air-tight when the top opening was sealed. The water bath was used to obtain steady flow rates and to flash the R-452b, which was extracted from the bottom of its container.

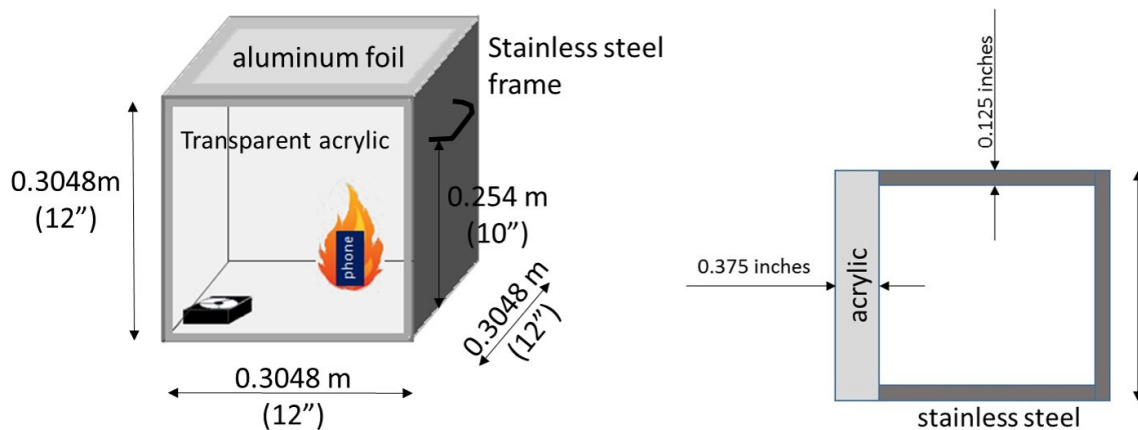

Figure 3.2. Schematic and top view of the chamber.

After initial tests with a hot wire, a chimney was introduced on the top as shown in Figure 3.3 and Figure 3.4.

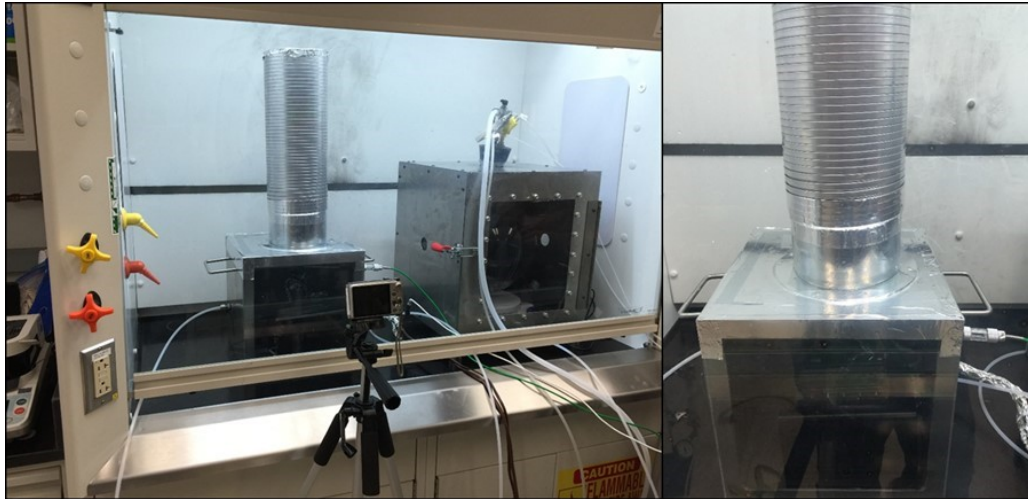

Figure 3.3. Front views of the assembled chimney on the chamber.

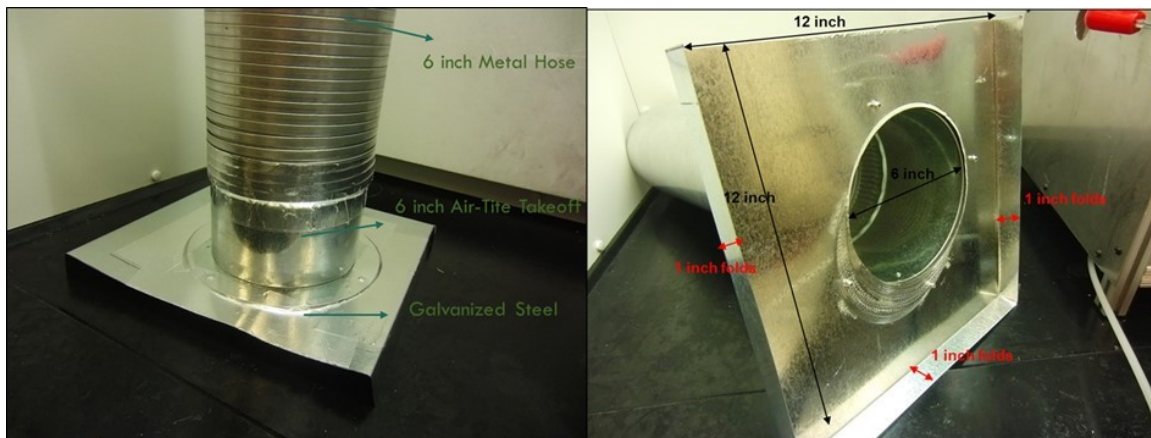

Figure 3.4. Front and bottom views of the assembled chimney.

The experiments can be divided into two methods based on chamber gas condition when the ignition source was introduced: premixed and diffusion. For most tests, the chimney was sealed with aluminum foil after the ignition source was installed inside the enclosure.

For the premixed method, refrigerant was then injected at a controlled rate until the desired concentration was reached. A fan was activated for 5 min to create a homogenous mixture and then the ignition source was energized.

For the diffusion method, the ignition source was initially energized while the enclosure was filled with only air; refrigerant was introduced while the ignition source was already active. No fans were used for the diffusion method. All of the experiments were recorded by a video camera. After the experiments, the contents of the chamber were flushed with nitrogen gas.

Concentrations of the gaseous refrigerants in air were monitored by a portable gas detector (New Cosmos, XP-3140) as shown in Figure 3.5. Simultaneous monitoring of combustible gas and oxygen concentrations, ranging from 0 – 100% of the lower flammability limit (LFL), is

available by measuring thermal conductivity. Humidity was measured by the humidity probe shown in Figure 3.5.



Figure 3.5. Portable gas detector (left), humidity probe (center), and computer fan (right).

Refrigerant Properties

R-32, R-1234yf, R-1234ze, and R-452B were tested with each ignition source.

The UMD team investigated the Lower Flammability Limits (LFL), the Upper Flammability Limits (UFL), the average between the LFL and UFL, and the stoichiometric concentrations of each refrigerant, summarized in Table 3.1. Stoichiometry combustion, Autoignition Temperatures (AIT), and Minimum Ignition Energy (MIE) and Quenching Distance (d_q) of refrigerants are shown in Table 3.2, 3.3, and 3.4, respectively.

Table 3.1. Relevant concentrations for the tested refrigerants.

Refrigerant	Volume Percent in Air				
	LFL	UFL	Mean	Dry Stoic.	Wet Stoich
R-32	14.4 ^{a,b}	29.3 ^b	21.8	17.4	17.4
R-1234yf	6.2 ^{a,c}	12.3 ^c	9.3	7.8	7.2
R-1234ze	6.5 ^a	9.5 ^{d,e}	8.0	7.8	7.2
R-452B	11.9 ^f	24.0	18.0	14.7	14.3

(a) ANSI/ASHRAE Standard 15 and 34 (2013)

(b) Wilson et al (2002)

(c) Minor et al (2012)

(d) AHRI project 8009 Final Report

(e) Honeywell (2008a)

(f) Chemours (Based upon LFL, Nominal = 0.309 kg/m³)

Table 3.2. Stoichiometric combustion of R-32, R-1234yf, R-1234ze, and R-452B.

Refrigerant	Air	Stoichiometry
	R-32	Wet
Dry		$CH_2F_2 + (O_2 + 3.76N_2) \rightarrow CO_2 + 2HF + 3.76N_2$

R-1234yf and R-1234ze	Wet	$C_3H_2F_4 + 2.5(O_2+3.76N_2) + H_2O \rightarrow 3CO_2 + 4HF + 9.4N_2$
	Dry	$C_3H_2F_4 + 2.5(O_2+3.76N_2) \rightarrow 2CO_2 + 4HF + 9.4N_2 + COF_2$
R-452B	Wet	$0.818 CH_2F_2 + 0.037 C_2HF_5 + 0.145 C_3H_2 + 1.217(O_2+3.76N_2) + 0.219 H_2O \rightarrow 1.327CO_2 + 2.401HF + 4.577N_2$
	Dry	$0.818 CH_2F_2 + 0.037 C_2HF_5 + 0.145 C_3H_2 + 1.217(O_2+3.76N_2) \rightarrow 1.108CO_2 + 1.963HF + 4.577N_2 + 0.219COF_2$

Table 3.3. Minimum ignition energies

Refrigerant	MIE	Description
R-32	30-100 mJ ^{a,b,d,e}	12-Liter vapor MIE test apparatus
	20 mJ ^d	Theoretical estimate
R-1234yf	2000 mJ ^d	Theoretical estimate
	5000-10000 mJ ^{a,b}	12-Liter vapor MIE test apparatus
	3000-10000 mJ ^c	Theoretical estimate
	>1000 mJ ^c	Tests conducted in 12 L flask to minimize wall quenching
	200 mJ ^c	Ineris experiments (not capacitive test, so not relevant, compared to other values)
R-1234ze	61,000-64,000 mJ ^{a,c}	Tests conducted at 54°C, not flammable at ambient temperature
R-452B	Not available	Not available

(a) AHRI project 8009 Final Report

(b) Minor et al (2008)

(c) Spatz (2008)

(d) Minor et al. (2009)

(e) Monforte et al. (2009)

Table 3.4. Autoignition temperatures and quenching distances.

Refrigerant	AIT, °C	Quenching Distance (d _q)
	648 ^a	
R-32	> 700 ^b	7.55 mm ^{h,i}
	764 (+/-10) ^c	
R-1234yf	405 ^{d,e}	24.8 mm ^{h,i}
	405-420 ^d	
R-1234ze	368 ^{f,g}	Not available
R-452B	Not available	Not available

- (a) Goetzler (1998)
- (b) Richard et al (2012)
- (c) Boussouf et al (2014)
- (d) Monforte et al (2009)
- (e) Spatz (2008)
- (f) Safety data sheet (National Refrigerant)
- (g) Solstice ze refrigerant (Honeywell)
- (h) JSRAE (2014)
- (i) Takizawa et al (2015)

Procedures

For most tests the chamber was opened and the ignition source was installed. The chamber top was then sealed with aluminum foil. The fan was energized and the hood sash was lowered.

The refrigerant was introduced at a controlled rate. The gases in the enclosure were mixed by the fan such that conditions in the chamber were homogeneous. A check valve allowed the mixture to vent during this filling process to prevent over-pressurization. The volumetric flow rate was 1 L/min.

Assuming well-mixed conditions in the chamber, the refrigerant mass fraction as a function of time is given by conservation of species by:

$$Y_R = 1 - e^{-\frac{\dot{M}_{in}}{M_{CV}} t}, \quad (1)$$

where \dot{M}_{in} , and M_{CV} are the refrigerant mass flow rate and the total mass of gases in the chamber, respectively. M_{CV} is found from:

$$M_{CV} = V(X_{air}\rho_{air} + X_{R32}\rho_{R32}), \quad (2)$$

where V , X_{air} , X_{R32} , ρ_{air} , and ρ_{R32} are the volume of the chamber, mole fraction of air and R-32, and density of air and R-32, respectively. The density of R-32 gas and air are 2.155 kg/m³ and 1.1839 kg/m³, respectively at 25 °C. The refrigerant mole fraction is:

$$X_{R32} = Y_{R32} \frac{MW_{mix}}{MW_{R32}}, \quad (3)$$

where MW_{mix} and MW_{R32} are molar masses of the gas mixture and R-32. Quantity MW_{mix} is defined as

$$MW_{mix} = X_{air} MW_{air} + X_{R32} MW_{R32}. \quad (4)$$

Figure 3.6 shows the predictions of Eq. (3) for three flow rates of R-32. The refrigerant mole fraction was confirmed with the gas analyzer with the assumption of well-mixed conditions in the chamber.

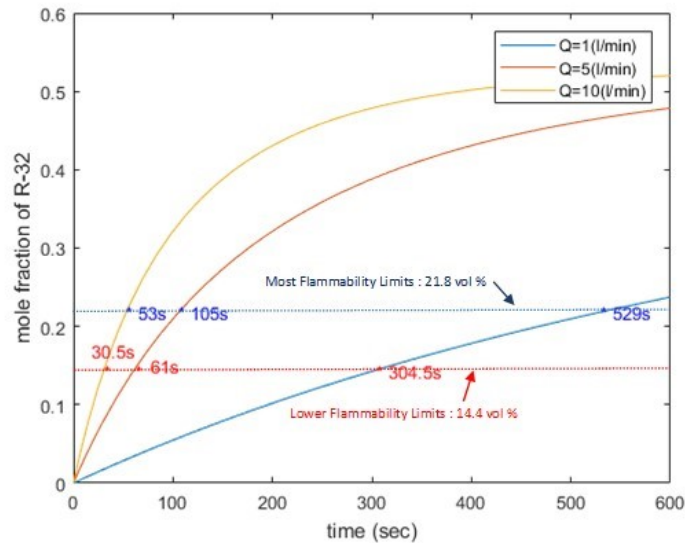

Figure 3.6. Mole fraction of R-32 in the 27 L chamber as a function of time.

After a homogenous mixture was created in the chamber, the mixing fan was turned off and the ignition source was activated for premixed tests. The results of each test were recorded by a video camera at 30 frames per second. Following each test, gaseous nitrogen was injected to suppress burning and to fully flush the chamber contents. Tests were repeated for verification.

Calibration of Rotameter and Gas Analyzer Calibration

The gas analyzer and rotameter were calibrated for all four refrigerants with results shown in Figure 3.7 and Figure 3.8. To calibrate the rotameter a bubble flowmeter measurement was used. The rotameter calibration is shown in Figure 3.7.

The gas analyzer was factory-calibrated for R-32 gas. A thermal conductivity sensor is utilized by the sensor, so the XP-3140 can also be used for other refrigerants pending calibration. For the calibration of the gas analyzer, the concentration of refrigerants was measured with a partial pressure method in a 12 L flask, shown in Figure 3.9. First, the chamber was evacuated by a vacuum pump until reaching about -101 kPa_g and a known concentration of refrigerant was introduced using a partial pressure method with a pressure gauge (Ashcroft DG25). Atmospheric

pressure was reached by filling the remainder of the flask with dry air. Then, the rubber stopper was opened slightly to insert the gas analyzer sensor into the chamber to measure the known concentration and to record the output of the meter as shown in Figure 3.8. The correction functions of sensor output were calculated based upon the heat capacity and density of each refrigerant. Thermal hand-calculations plots were also shown on the plots. The gas analyzer calibration with partial pressured method was used for ignition sources testing.

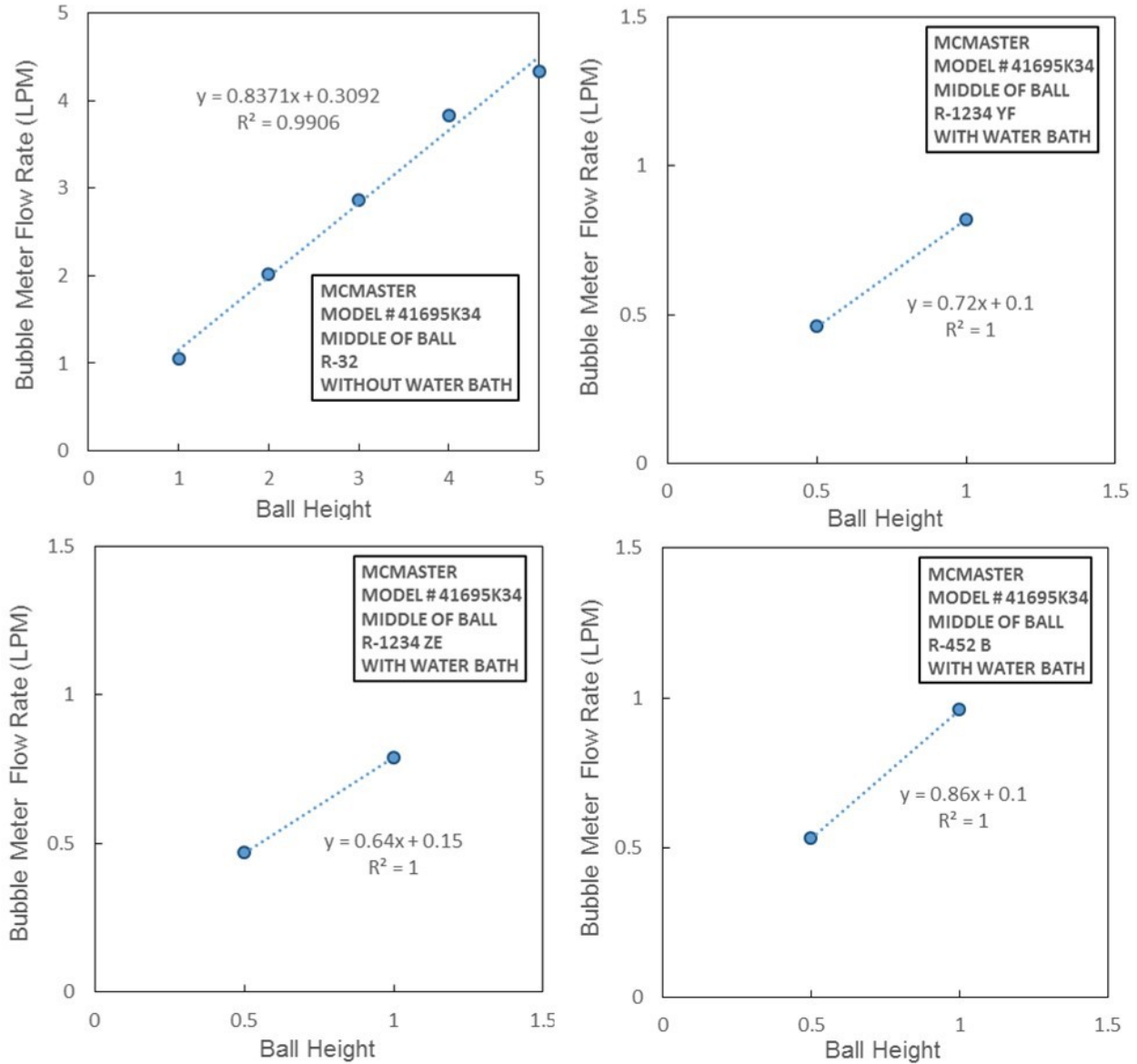

Figure 3.7. Rotameter calibration.

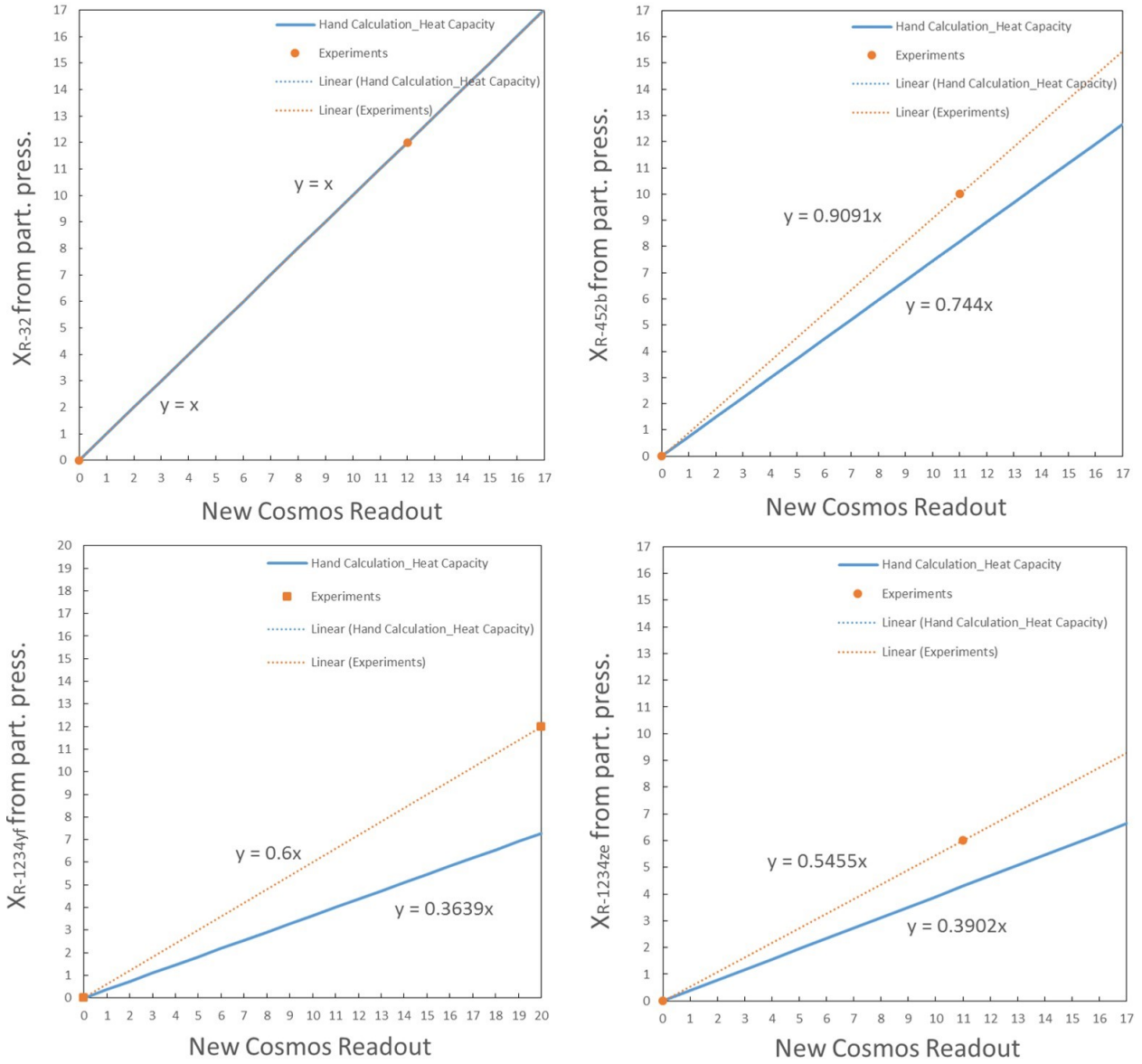

Figure 3.8. Gas analyzer calibration.

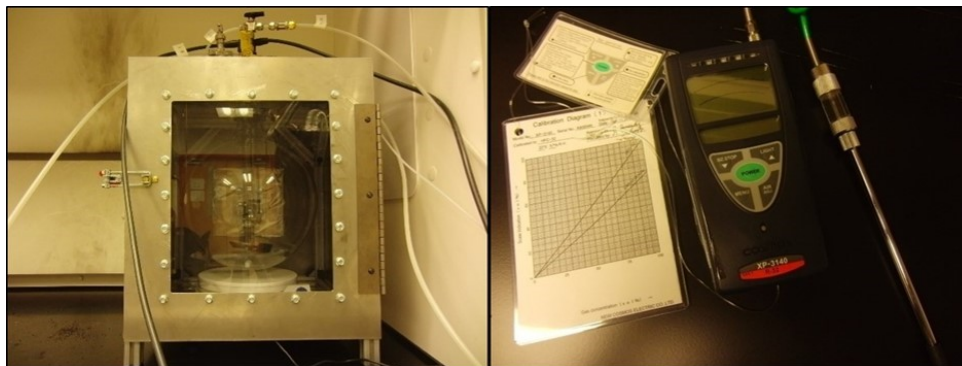

Figure 3.9. The partial pressure apparatus and the gas analyzer.

Deflagrations versus Localized Flames

The flames observed here are described as either deflagrations or localized flames. Deflagration is used to describe a flame that spreads in all directions to burn in nearly all areas of the chamber. Localized flame is used to describe small blue flames that remain near and above the sources, but do not propagate outward or downward.

4 Hot Wire Results

A resistively heated Nickel-Chromium wire was tested. This wire contains 80% nickel and 20% chromium. AC current is applied from a Variable AC controller (Variac). Three multimeters, one Type-K thermocouple, and one Variac were used to measure the electric current, voltage, and the electrical resistance as shown in Figure 4.1. The correlations of the electrical properties are shown in Figure 4.2.

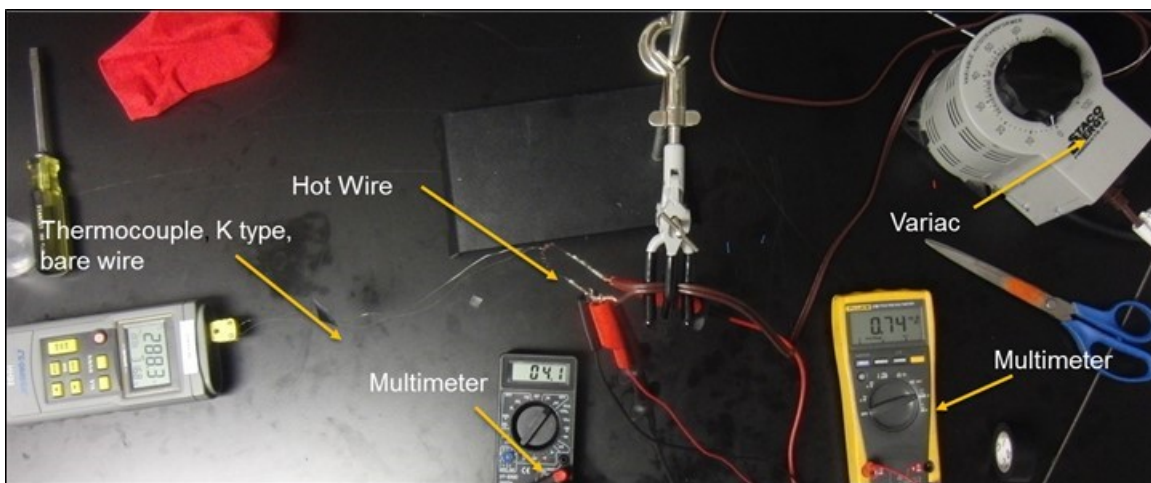

Figure 4.1. NiCr wire temperature measurement.

Hot wire testing of R-32, R-1234yf, R-1234ze, and R-452B was conducted. In the initial tests, R-32 was released into the test chamber and then mixed by a fan. The voltage was increased at a slow and steady rate from for Tests 1 – 5.

Table 4.1 summarizes the hot wire testing of R-32 in quiescent conditions. To reduce the possibility of unexpected hazards caused by fire, approximately 8% and 10% of the refrigerant (lower than the LFL of 14.4%) were used for baseline testing. Voltage through the wire was slowly increased in the premixed conditions and no ignition was observed for these low concentration tests. Next, similar tests were repeated with flammable mixtures containing of 13% and 17% R-32. Deflagrations were seen in both flammable mixtures when the voltage reached approximately 8 VAC. The flame propagated upward from the hot wire until reaching the top of the chamber and then gently downward for all experiments with R-32, as shown in Figure 4.3.

R-32 was also released into the chamber using a diffusion method whereby the wire was heated to its steady state temperature at 8 VAC and then refrigerant was introduced. The fan was not activated for the diffusion-style experiments. Test conditions are summarized for Tests 6. Ignition was observed with a blue localized flame as shown in Fig 4.4. After a few seconds of flame propagation, the flow of refrigerants was terminated and the flame was extinguished by nitrogen gas. Because the mixture was not thoroughly mixed, the concentration obtained from hand-calculation was more accurate than the gas analyzer concentration, but the exact concentration near the wire was not known.

Similar tests were conducted for the other refrigerants, as shown in Table 4.2. The mixing fan was activated only for Test 7. In this test (see Fig. 4.5), R-1234yf ignited with a rapid deflagration and a bang. To prevent subsequent rapid deflagrations, the mixing fan was turned off before igniting and the aluminum foil was replaced with thin plastic wrap.

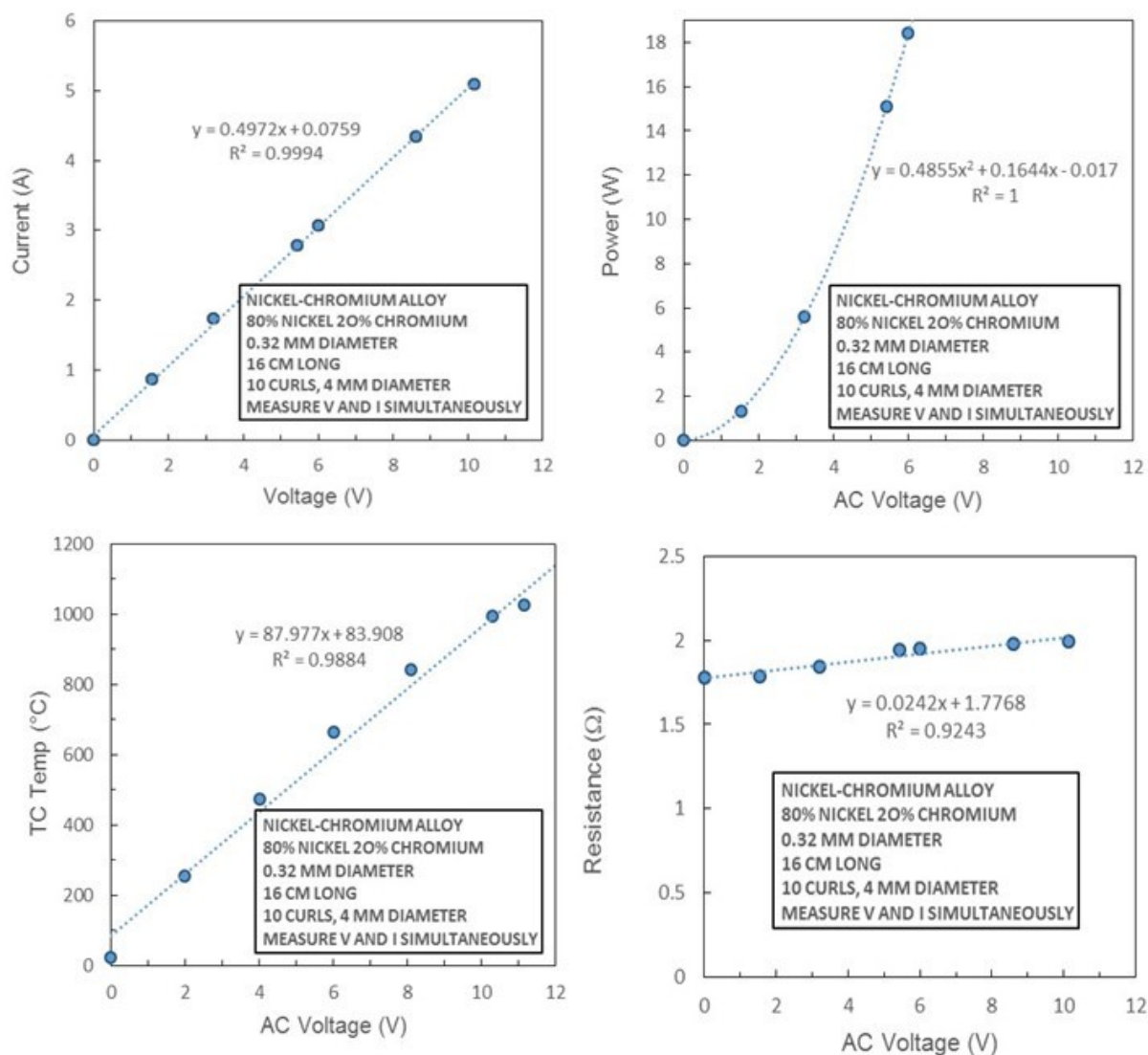

Figure 4.2. Electrical properties of NiCr wire.

Table 4.1. Hot wire (R-32) results. Temperature and RH were not measured, but are estimated at 21.7–22.5 °C and 17–37%, respectively.

Test	Mole fraction	Method	Excitation (VAC)	Wire Temperature, °C	Ignition
1	0.078 (Lean)	Premixed	10-12	863 – 1140	No
2	0.100 (Lean)	Premixed	10-12	863 – 1140	No
3	0.096 (Lean)	Premixed	10-12	863 – 1140	No
4	0.130 (Lean)	Premixed	8	788	Deflagration
5	0.170 (Near Stoich)	Premixed	7-8	700 - 788	Deflagration
6	0.115	Diffusion	8	788	Localized flame



Figure 4.3. Hot wire in R-32 (premixed), 17% (LFL=14.4%).



Figure 4.4. Hot wire in R-32. The flammability limit is estimated at 11.5% concentration of R-32.

Table 4.2. Hot wire (R-1234yf, R-1234ze, and R-452B, premixed) results. Temperature and RH were not measured, but are estimated at 21.7–22.5 °C and 17–37%, respectively.

Test	Refrigerant	Mole fraction	Excitation	Wire Temperature	Ignition
7	R-1234yf	0.080 (near stoich)	8 VAC	788 °C	Localized Flame
8	R-1234ze	0.065 (near stoich)	8 VAC	788 °C	Deflagration
9	R-452B	0.145 (near stoich)	8 VAC	788 °C	Deflagration

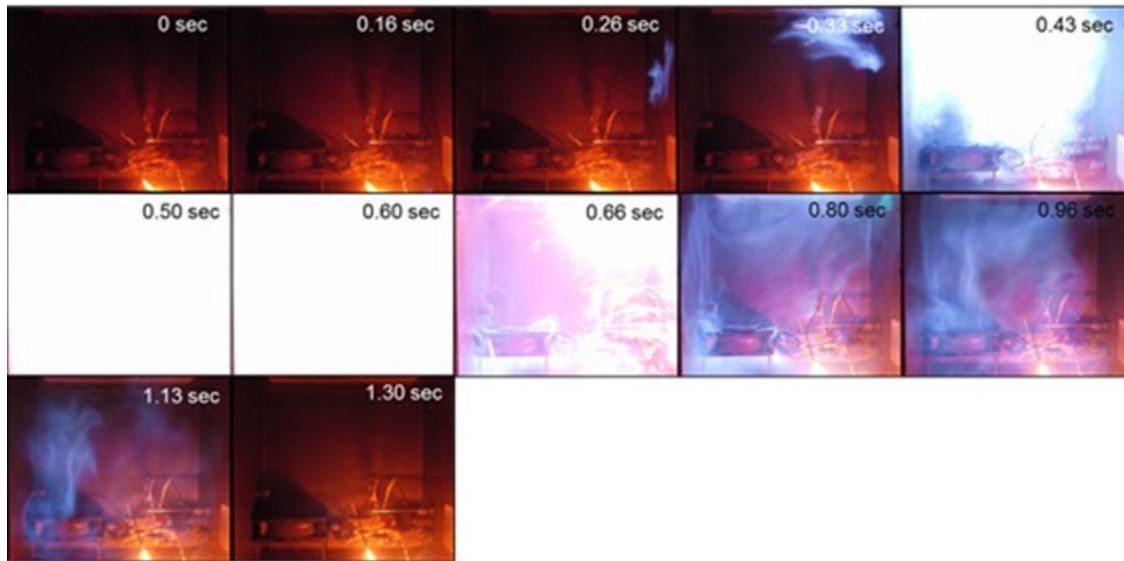

Figure 4.5. Hot wire in R-1234yf (Premixed): 8% (LFL = 6.2%).

R-1234ze and R-452B were tested with the test conditions in Table 4.2. Deflagrations were observed from both refrigerants. Figure 4.6 depicts an upward propagating flame from 6.5% R-1234ze testing, corresponding to the LFL of R-1234ze. The blue flame did not propagate downward after reaching the top of the chamber. The deflagration observed from R-452B is illustrated in Figure 4.7, where upward propagation followed by downward propagation was observed.

Premixed tests were repeated for all four flammable refrigerants at stoichiometric conditions with parameters detailed in Table 4.3. The flame propagation behavior at stoichiometric conditions was consistent with the previous round of premixed experiments, as illustrated in Figure 4.8. The voltage was increased slowly through a Variac and all four refrigerants were ignited by the wire around 9-9.5V. Voltage was measured by a multimeter. The plastic wrap effectively allowed for pressure release.



Figure 4.6. Hot wire in R-1234ze (Premixed): 6.5% (LFL = 6.5%).

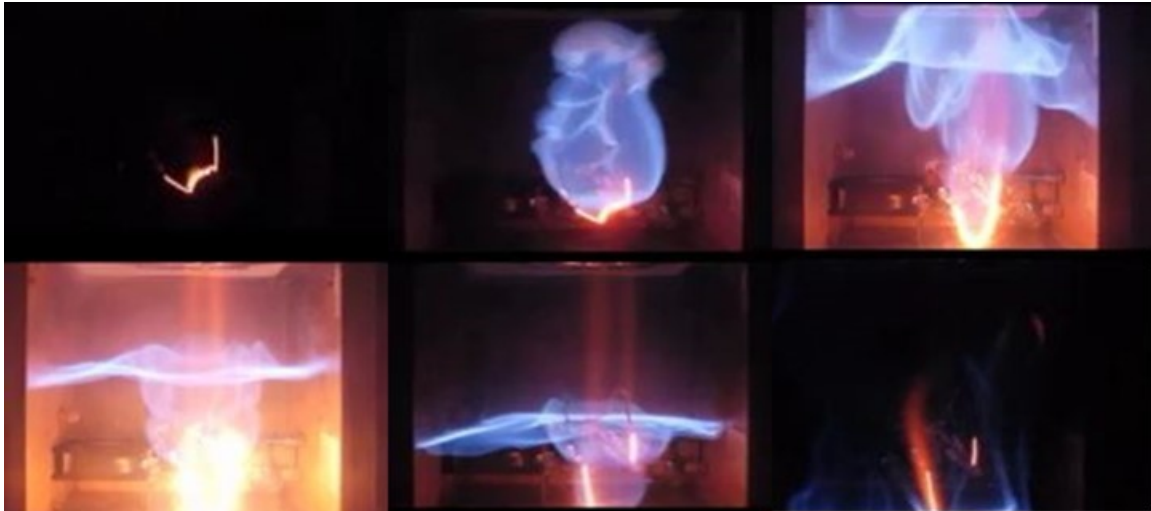

Figure 4.7. Hot wire in R-452B (Premixed): 14.5% (LFL = 11.9%).

Table 4.3. Hot wire stoichiometric results (premixed). Temperature and RH were not measured, but are estimated at 21.7–22.5 °C and 17–37%, respectively.

Test	Refrigerant	Mole fraction	Voltage (AC)	Wire Temperature	Ignition
10	R-32	0.174	8.9	863 °C	Deflagration
11	R-452B	0.147	9.4	911 °C	Deflagration
12	R-1234yf	0.078	9.5	921 °C	Deflagration
13	R-1234ze	0.078	9.5	921 °C	Deflagration

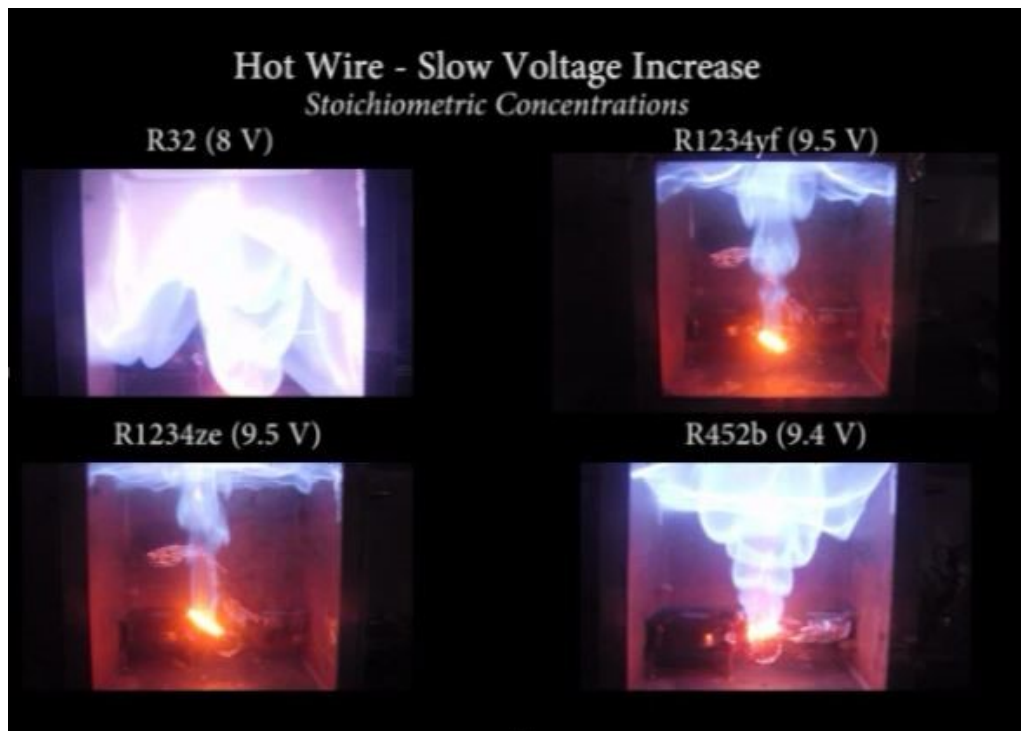

Figure 4.8. Deflagrations observed from slow voltage increase of hot wire in stoichiometric four refrigerant mixtures.

5 Safety Match Results

A wooden safety match was sealed inside the chamber and the match head was wrapped with a Nickel-Chromium wire for ignition, as shown in Figure 5.1. The safety match experiments were not affected by the presence of the lighter. The energy supplied to the wire was controlled by a variable AC controller (Variac).

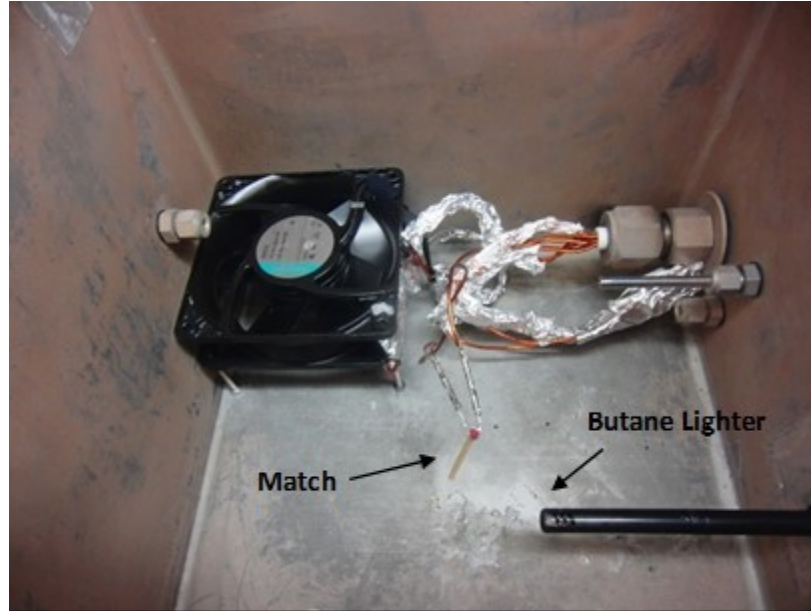

Figure 5.1. Test chamber with safety match installed.

Safety match experiments were conducted for all four refrigerants at stoichiometric conditions. Refrigerant was introduced at a flow rate of 1 L/min with the chamber fan activated. The gas analyzer monitored the concentration until the desired concentration was achieved. The fan was deactivated and quiescent conditions were obtained. Afterwards, the safety match was ignited by a hot wire, which was supplied with 1-2 VAC for a few seconds. Caution was taken to ensure that the hot wire ignited the safety match and not the mixture itself; with such a small wire length, low voltage level, and short duration, the hot wire alone would not have been able to ignite the mixture.

Four refrigerants were tested with the test parameters in Table 5.1. All refrigerants were ignited by the safety match as pictured in Figure 5.2. A localized flame was observed in R-1234yf. For R-32, R-452B, and R-1234ze, deflagrations were observed where the flames propagated upwards from the safety match and then gently downward after reaching the top of the chamber.

Table 5.1. Safety match results at nearly stoichiometric conditions. Temperature and RH were not measured, but are estimated at 21.7–22.5 °C and 17–37%, respectively.

Refrigerant	Mole fraction	Ignition
R-32	0.170	Deflagration
R-452B	0.155	Deflagration
R-1234yf	0.072	Localized
R-1234ze	0.098	Deflagration

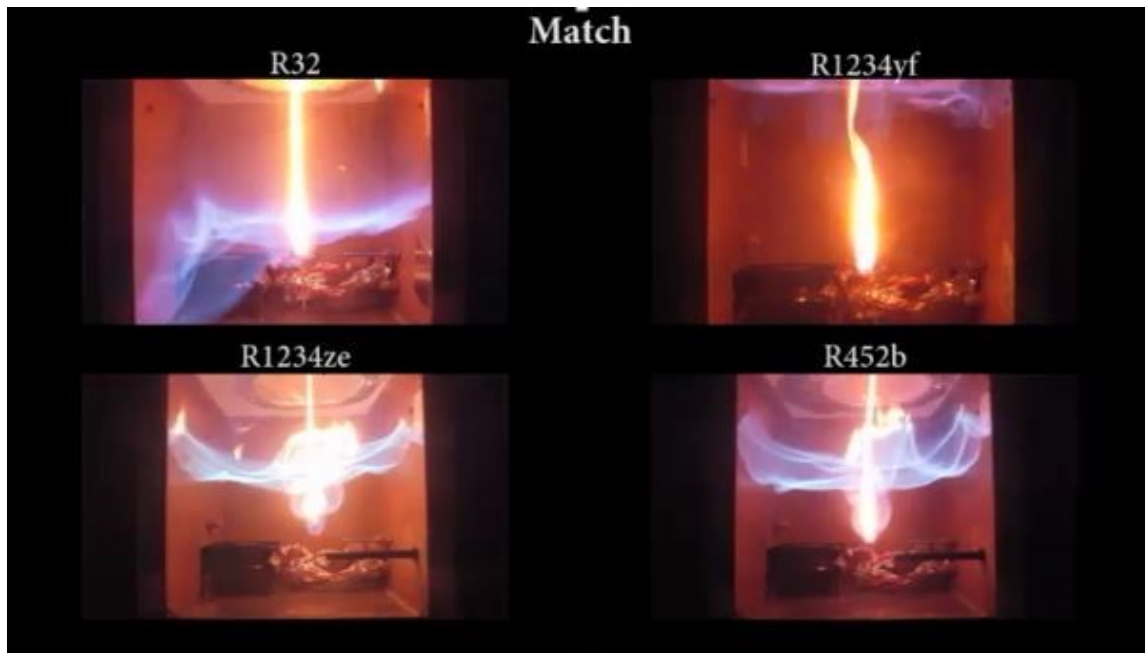

Figure 5.2. Safety match tests: (a) R-32: 17% (LFL = 14.4%), (b) R-1234yf: 7.2% (LFL = 6.2%), (c) R-1234ze: 9.8% (LFL = 6.5%), and (d) R-452B: 15.5% (LFL = 11.9%).

6 Lighter Flame Insertion Results

A barbeque lighter was tested in stoichiometric mixtures of refrigerant and air. Refrigerant was introduced at a flow rate of 1 L/min with the chamber fan activated. The gas analyzer monitored the concentration until the desired concentration was achieved. The fan was deactivated and quiescent conditions were obtained. The barbeque lighter was ignited in air outside the chamber and then inserted into the chamber.

All four refrigerants were tested with the test conditions in Table 6.1. All four refrigerants were ignited by the barbeque lighter insertion as shown in Figure 6.1. A localized flame was observed in R-1234yf, R-452B, and R-1234ze. A deflagration was observed in R-32, where the flames propagated upwards from the lighter and then gently downward after reaching the top of the chamber.

Table 6.1. Lighter flame insertion results at nearly stoichiometric conditions. Temperature and RH were not measured, but are estimated at 21.7–22.5 °C and 17–37%, respectively.

Refrigerant	Mole fraction	Ignition
R-32	0.160	Deflagration
R-452B	0.127	Localized
R-1234yf	0.078	Localized
R-1234ze	0.076	Localized

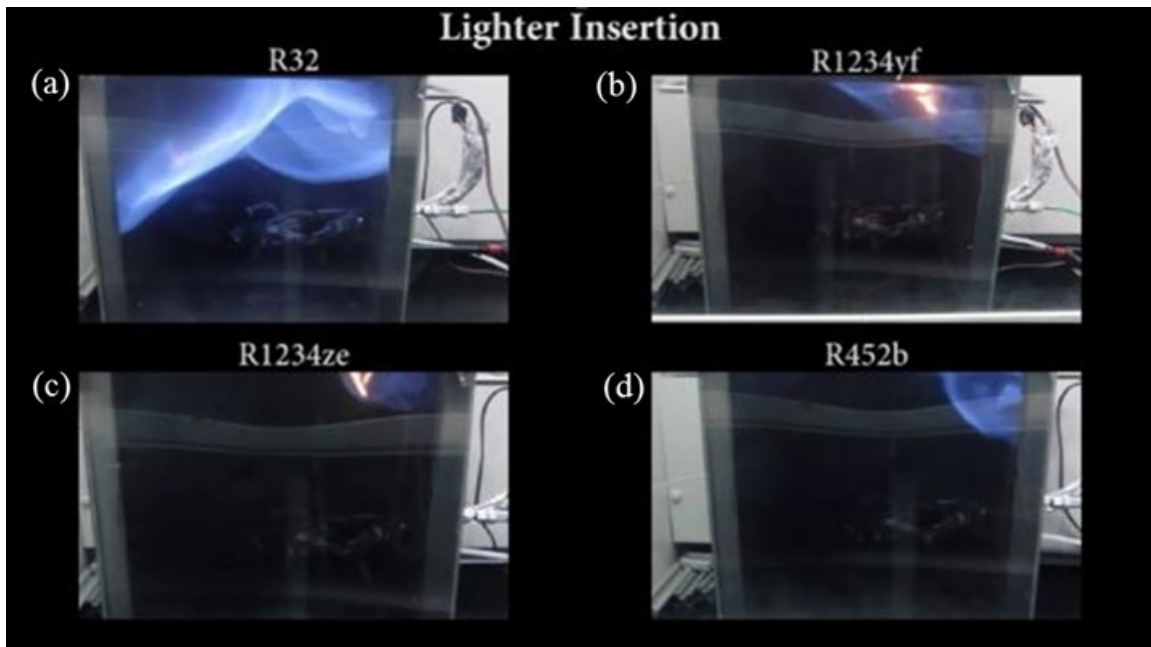

Figure 6.1. Lighter flame insertion results for (a) R-32: 16% (LFL = 14.4%), (b) R-1234yf: 8% (LFL = 6.2%), (c) R-1234ze: 7.5% (LFL = 6.5%), and (d) R-452B: 13% (LFL = 11.9%).

7 Leak Impinging on Candle Results

In this series of candle experiments, refrigerants were released into the chamber from one of two different locations, a high and low leak, while a candle was already burning. The locations are shown in Figure 7.1. No candle is visible in these images.

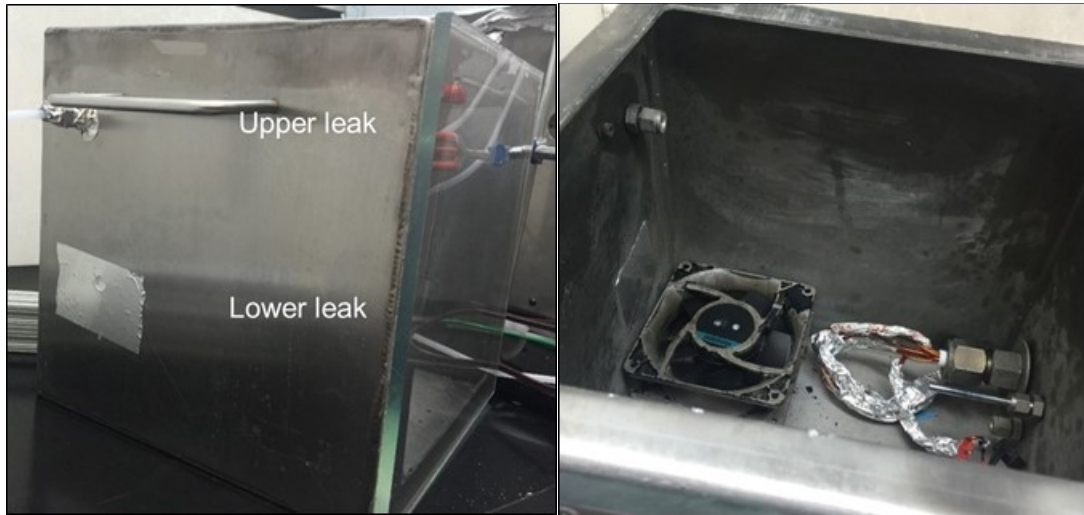

Figure 7.1. Location of leakage.

The first test series featured R-32 at the lower leak location. The test conditions are summarized in Tables 7.1. Long candles (150 mm high) were used first. No localized flames or deflagration flames were observed. The candle flame location was higher than leak location. It can be assumed that the refrigerant did not fully diffuse up to the candle without any fan activation. Thus, short candles (50 mm high) were used and the candles were lower than refrigerant leak location. Interestingly, localized blue flames were seen around the short candles, as pictured in Figure 7.2, prior to the candle being extinguished. No deflagrations were observed in this configuration. The

Table 7.1. Lower leak candle testing of R-32 results. Temperature and RH were not measured but are estimated at 21.7–22.5 °C and 17–37%, respectively.

Mole fraction	Candle Size	Extinction Time, s	Ignition
0.048	Long	88	None
0.065	Long	121	None
0.092	Long	177	None
0.087	Long	167	None
0.035	Short	62	Localized
0.047	Short	84	Localized
0.049	Short	88	Localized
0.05	Short	92	Localized
0.044	Short	80	Localized
0.052	Short	95	Localized
0.038	Short	68	Localized
0.053	Short	97	Localized
0.041	Short	73	Localized
0.046	Short	83	Localized

candle extinguished around 4.6% - 7.3% of R-32, as estimated using a hand calculation of leak rate and time. The mixture was not homogeneous, so this concentration is approximate.



Figure 7.2. From lower leak candle testing, the candle extinguishes at 4.7% R-32. A blue localized flame was observed.

A second series of tests with R-32 were conducted. Test parameters are summarized in Table 7.2. Short candles (15 mm wick, 50 mm high) were used. R-32 was released into the chamber from the upper inlet while the candle was already burning. The candle was located in the center for the first three experiments. No ignition was observed. Next, the candle location was varied to confirm this result at various locations. No localized flames or deflagrations were observed in upper leak candle testing, as shown in Figure 7.3. There was no effect of candle location in the small box. Turbulent extinction and oxygen vitiation were ruled out.

Table 7.2. Upper leak candle testing of R-32 results. Temperature and RH were not measured, but are estimated at 21.7–22.5 °C and 17–37%, respectively.

Mole fraction	Candle location	Extinction Time (s)	Ignition
0.082	Center	156	None
0.06	Center	111	None
0.062	Center	115	None
0.074	Back left	140	None
0.063	Front right	117	None



Figure 7.3. Upper leak location with approximately 6% R-32. No blue flame observation.

Next, both high leak and low leak experiments were conducted in R-1234yf with the test conditions indicated in Table 7.3. The R-1234yf was released into the chamber while the candle was already burning. Short candles (50 mm high) and long candles (over 150 mm high) were used at the center location of the chamber.

Table 7.3. Candle testing of R-1234yf results. Temperature and RH were not measured, but are estimated at 21.7–22.5 °C and 17–37%, respectively.

Refrigerant	Mole fraction	Leak location	Candle location	Extinction Time (s)	Ignition
R-1234yf	0.064 (near LFL)	Upper	Center	119	Localized
R-1234yf	0.044	Upper	Center	80	Localized
R-1234yf	0.036	Lower	Center	65	Localized

As shown in Figure 7.4 and Figure 7.5, blue localized flames were observed prior to extinction. The localized flames appeared larger than the previous localized flames from R-32. The candle was extinguished by R-1234yf at approximately 3.6 - 6.4%. Again, oxygen vitiation and turbulence extinction were been ruled out.



Figure 7.4. Upper leak with approximately 4% R-1234yf.



Figure 7.5. Lower leak with approximately 3% R-1234yf.

Lower leak tests of R-1234ze and R-452B were conducted with the test parameters in Table 7.4. Short candles (50 mm high) were used at the center location. For R-1234ze, a blue localized flame was observed, but no flames were observed during R-452B tests prior to extinguishment of the candle flame. Figure 7.6 summarizes this series of lower leak candle tests.

Table 7.4. Candle testing of R-1234ze and R-452B results. Temperature and RH were not measured, but are estimated at 21.7–22.5 °C and 17–37%, respectively.

Refrigerant	Mole fraction	Leak location	Candle location	Extinction Time (s)	Ignition
R-1234ze	0.030	Lower	Center	68	Localized
R-452B	0.040	Lower	Center	80	None
R-452B	0.035	Lower	Center	66	None

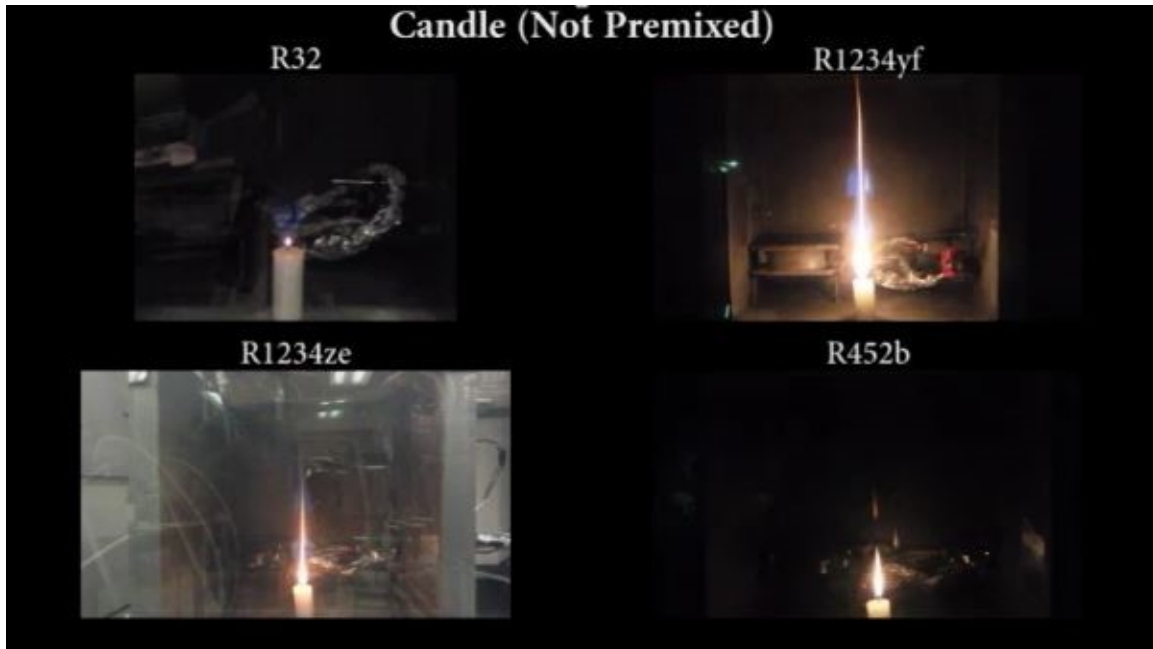

Figure 7.6. All refrigerants extinguish candles, after a localized flame was observed from R-32, R-1234yf, and R1234ze: (a) R-32: ~5% (LFL = 14.4%), (b) R-1234yf: ~3% (LFL = 6.2%), (c) R-1234ze: ~3% (LFL = 6.5%), (d) R-452B: ~3.5% (LFL = 11.9%).

8 Cigarette Insertion Results

Before testing the ignition potential of a cigarette, the temperature of a smoldering cigarette was measured by a bare thermocouple wire as shown in Figure 8.1. The maximum temperature of the cigarette was 490 °C.



Figure 8.1. Cigarette temperature measured by a bare thermocouple in air.

Cigarette testing was conducted with two different methods. In the first method, a cigarette was installed inside the chamber. The cigarette tip was connected to a Nickel-Chromium wire. The energy supplied to the wire was controlled by a variable AC controller. The chamber top was sealed with a chimney and refrigerant was introduced. The fan was activated until homogeneous conditions were reached and then deactivated. The cigarette was ignited by a hot wire which was supplied with 1-2 V. Caution was taken to ignite only the cigarette and not entire the mixture with the wire.

R-32 was tested through the first method with the following test conditions listed in Table 8.1. R-32 extinguished the cigarette within 10 minutes in each case. Re-ignition of the cigarette was attempted with the hot wire, but failed on each attempt.

Table 8.1. Cigarette results for R-32. Temperature and RH were not measured, but are estimated at 21.7–22.5 °C and 17–37%, respectively.

Refrigerant	Mole fraction	Ignition
R-32	0.180	
	0.175	None
	0.170	

The second method involved inserting a lit cigarette into the chamber of premixed refrigerant as shown in Figure 8.2. All four refrigerants were tested through this method with at least four attempted cigarette insertions each. Conditions were stoichiometric. The test parameters are summarized in Table 8.2.

All four refrigerants extinguished the cigarette within 100 s with the second method. The effect of oxygen deficiencies were ruled out by measuring the amount of time the cigarette was able to

burn inside the sealed chamber without any refrigerants present. The cigarette was able to burn to completion in 16 minutes, much longer than it burned with the refrigerant present.

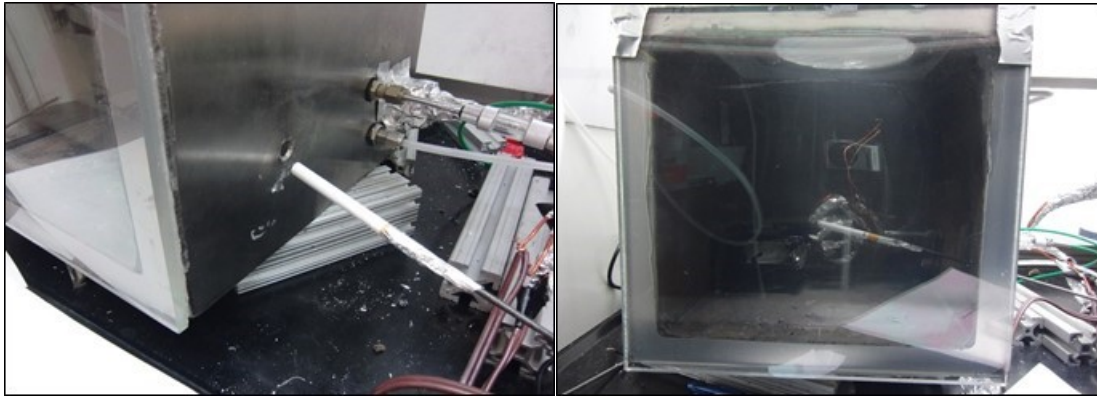

Figure 8.2. Insertion of a burning cigarette.

Table 8.2. Cigarette insertion results at nearly stoichiometric conditions.

Refrigerant	Mole fraction	Temperature	RH	Ignition
R-32	0.174	22 °C	41%	None
R-452B	0.147	22 °C	48%	None
R-1234yf	0.078	22 °C	41%	None
R-1234ze	0.078	22 °C	47%	None

9 Barbeque Lighter Results

The nozzle of a butane lighter was sealed inside the chamber with the trigger activated by an electrical actuator. Tested involved three methods. In the first method, R-32 was released into the chamber while the barbeque lighter was burning as shown in Figure 9.1. This is called the diffusion method. In the second method, premixed conditions were prepared inside the chamber, followed by activating the butane lighter. The lighter was able to sustain a butane flame in 0%, and 2%, but not at 3% R-32 as shown in Figure 9.2. For the third method, the chamber was filled with a stoichiometric mixture and the lighter was sparked with butane flowing. Spark ignition was attempted at least 10 times. All four refrigerants were tested with this third method.



Figure 9.1. Barbeque lighter in R-32 (first method).

R-32 experiments with the first and second methods are summarized in Table 9.1. For the diffusion testing, the barbeque lighter could not ignite above a concentration of 3.8% R-32 in air. For the second method, no refrigerant ignition was observed. Oxygen vitiation and turbulence extinction were ruled out.

With the third method, all four refrigerants were tested with the conditions in Table 9.2. The butane lighter did not ignite the mixture and only sparks were seen without any flame from all four refrigerants at stoichiometric conditions. The lighter was sparked with butane flowing into the premixed refrigerant at least 10 times for each refrigerant.

Table 9.1. Barbeque lighter results for R-32 (first and second methods).

Refrigerant	Mole fraction	Method	Ext time (s)	Ignition	Comments
R-32	0.038	Diffusion	68	None	Extinguished
	0-0.03	Premixed	N/A	None	Lighter flame ignited at 0%, 2%, but not at 3%



Figure 9.2. Barbeque lighter (second method) testing, with 2% R-32 (left) and 3% R-32 (right).

Table 9.2. Barbeque lighter summary, third method, for nearly stoichiometric conditions. Temperature and RH were not measured for this specific test data, but are estimated at 21.7–22.5 °C and 17–37%, respectively.

Refrigerant	Mole fraction	Ignition
R-32	0.170	None
R-452B	0.155	None
R-1234yf	0.072	None
R-1234ze	0.098	None

10 Plug and Receptacle Results

An apparatus was prepared to insert and remove a plug from a receptacle, as shown in Figure 10.1. A 3 A and 12 VDC actuator (Eco-Worthy Model AM-L11TGF12V100-T-1) was loaded in the test chamber to safely insert and remove the plug. The plug was fixed to the actuator using wire and aluminum tape. For the electric circuit, the receptacle was connected to a power supply and a 2240 W vacuum cleaner acted as the load on the plug; the vacuum cleaner was located outside of the chamber.

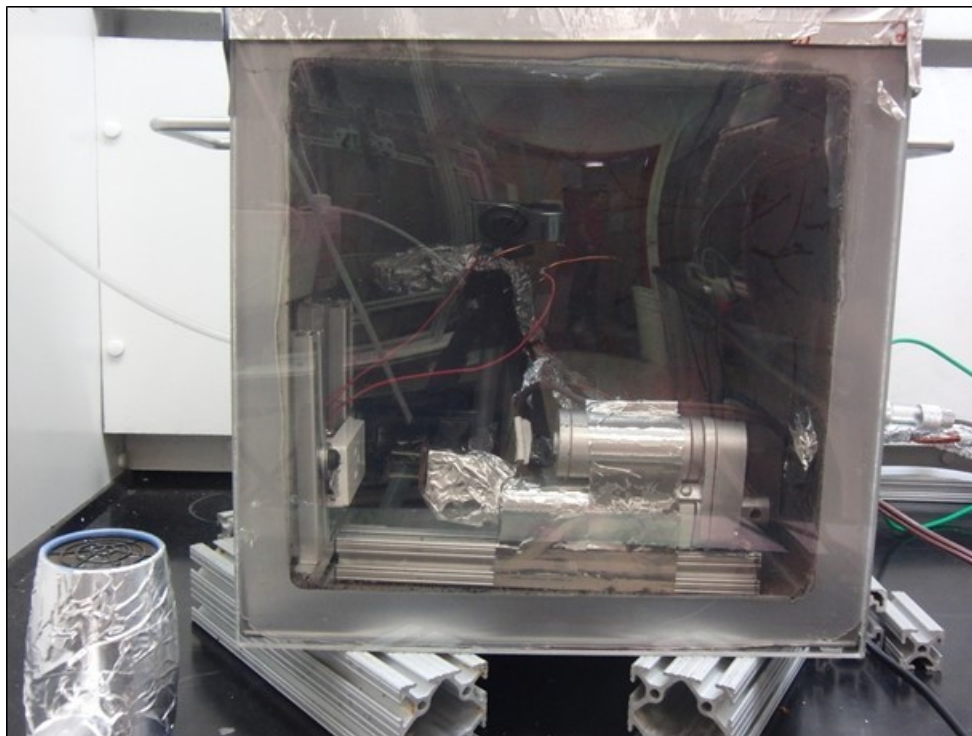

Figure 10.1. Plug insertion configuration. The load was a 1600 W (110 VAC) hair dryer.

Plug insertion tests were conducted for all four refrigerants. Refrigerant was introduced at a flow rate of 1 L/min with the chamber fan activated. The gas analyzer monitored the concentration until the desired concentration was achieved. The fan was deactivated and quiescent conditions were obtained. Sparks were observed every time the plug was inserted or removed. Ten insertion/removal cycles were performed for each test. Conditions were stoichiometric as shown in Table 10.1. No ignitions were observed.

Table 10.1. Plug insertion into socket results at nearly stoichiometric conditions. Temperature and RH were not measured, but are estimated at 21.7–22.5 °C and 17–37%, respectively.

Refrigerant	Mole fraction	Ignition
R-32	0.174	None
R-452B	0.147	None
R-1234yf	0.078	None
R-1234ze	0.078	None

11 Light Switch Results

A light switch (Model 1303-7W-Box) creates an arc each time it opens or closes under load. It was loaded in the windowed chamber as shown in Figure 11.1. This switch is rated for 15 A, 120 VAC. Also, a 3 A and 12 VDC actuator (Eco-Worthy Model AM-L11TGF12V100-T-1) was loaded in the test chamber to operate the switch in both directions. The load on the light switch was a 2240 W vacuum cleaner outside of the chamber.

It was difficult to see the sparks from the switch, so the casing was removed from a switch. The sparks were seen clearly without the case, as shown in Figure 11.2. This opened switch was not used for ignition tests.

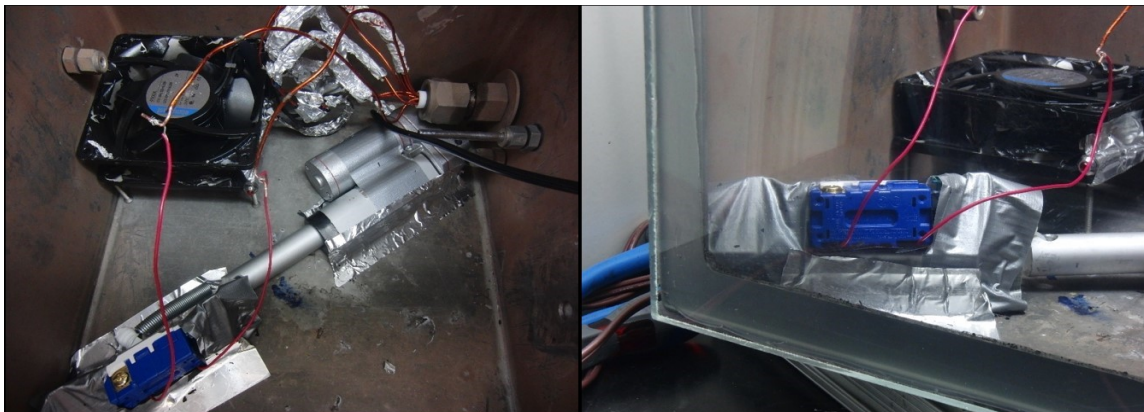

Figure 11.1. Test chamber interior for light switch testing.

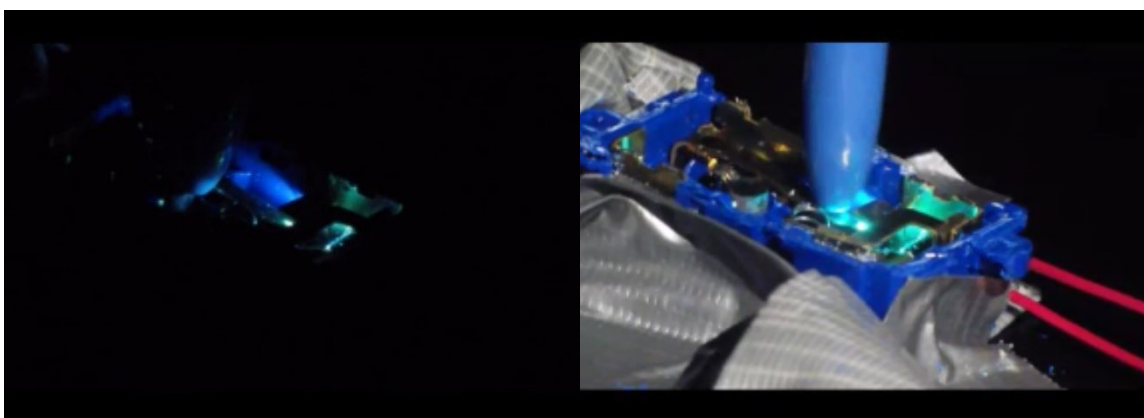

Figure 11.2. Light switch images with casing removed for spark viewing.

A new light was installed inside the chamber and the top vent was sealed with a chimney. Refrigerant was introduced at a flow rate of 1 L/min with the chamber fan activated. The gas analyzer monitored the concentration until the desired concentration was achieved. The fan was deactivated and quiescent conditions were obtained. The light switch was turned on and off for at least 20 cycles for each refrigerant.

All four refrigerants were tested with the test conditions in Table 11.1. No ignitions were observed.

Table 11.1. Light switch results at nearly stoichiometric conditions. Temperature and RH were not measured, but are estimated at 21.7–22.5 °C and 17–37%, respectively.

Refrigerant	Mole fraction	Ignition
R-32	0.174	None
R-452B	0.147	None
R-1234yf	0.078	None
R-1234ze	0.078	None

12 Hand Mixer Results

A hand mixer (Continental Electric Model CP43149, \$21.99) with a maximum power of 200 W was used as a potential ignition source. This mixer had an excitation of 110 VAC and dimensions of $0.21 \times 0.15 \times 0.11$ m, as shown in Figure 12.1. This mixer has vent holes that allow spark viewing, but to clearly see a spark, the plastic casing was temporarily removed as shown in Figure 12.2. Continuous blue sparks were visible from the motor, as shown in Figure 12.3.



Figure 12.1. Test chamber interior with mixer installed.

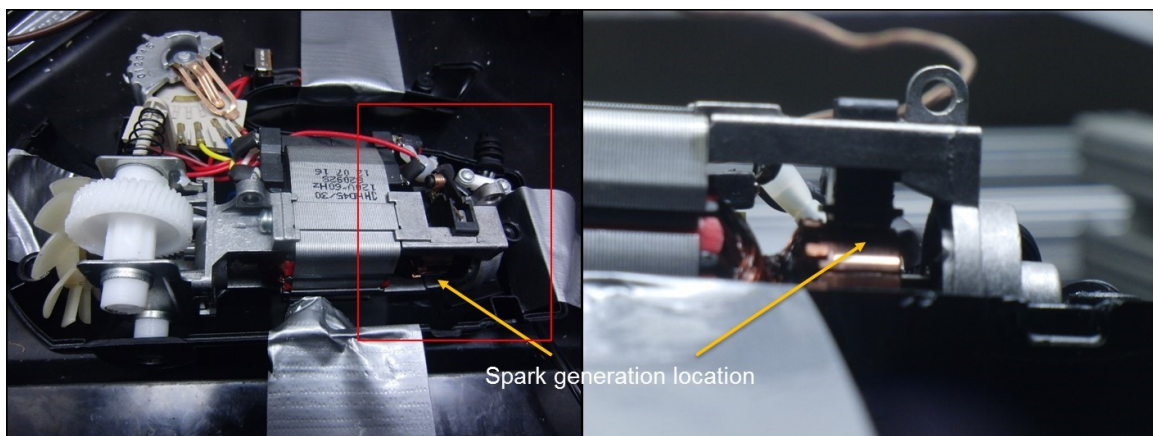

Figure 12.2. Top and front views of the hand mixer motor with its plastic case removed.

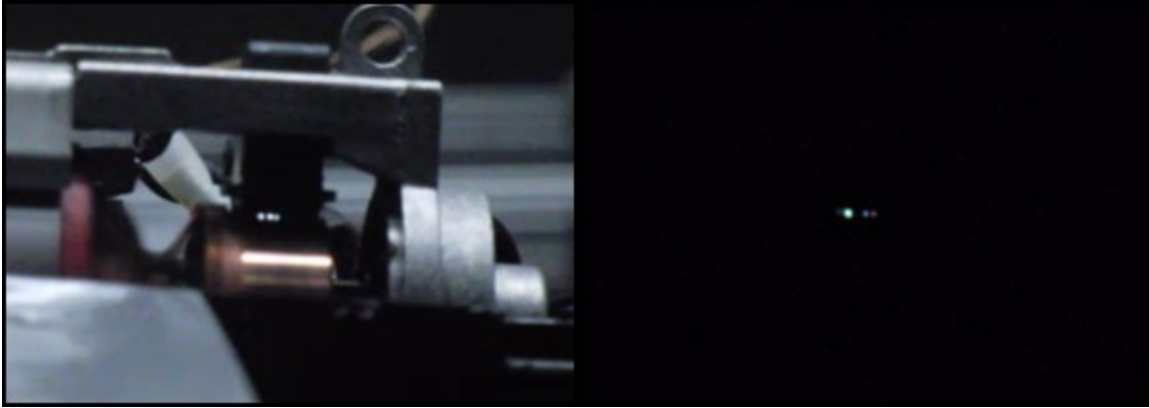

Figure 12.3. Sparks visible when the motor was exposed.

For each test, the shielded hand mixer was installed inside the chamber and the top vent was sealed with a chimney. Refrigerant was introduced at a flow rate of 1 L/min with the chamber fan activated. The gas analyzer monitored the concentration until the desired concentration was achieved. The fan was deactivated and quiescent conditions were obtained. The hand mixer was activated for at least 100 s. All four refrigerants were tested with the stoichiometric mixtures in Table 12.1. No ignitions were observed.

Table 12.1. Hand mixer results at nearly stoichiometric conditions.

Refrigerant	Mole fraction	Temperature	RH	Ignition
R-32	0.174	22 °C	32%	None
R-452B	0.147	22 °C	32%	None
R-1234yf	0.078	22 °C	32%	None
R-1234ze	0.078	22 °C	32%	None

13 Cordless Drill Results

Tests were performed with a 380 W, 18 VDC cordless drill (DeWalt Model DC970K-2-4, \$49.95), which has a brushed motor, as pictured in Figure 13.1. Excitation was with a DeWalt battery outside the chamber, for which the voltage was measured to be 18.5 V at maximum drill speed. The drill was loaded into the chamber and the top vent was sealed with a chimney. Refrigerant was introduced at a flow rate of 1 L/min with the chamber fan activated. The gas analyzer monitored the concentration until the desired concentration was achieved. The fan was deactivated and quiescent conditions were obtained. The drill was operated for 120 S. Continuous blue sparks were clearly visible from the brushed motor.

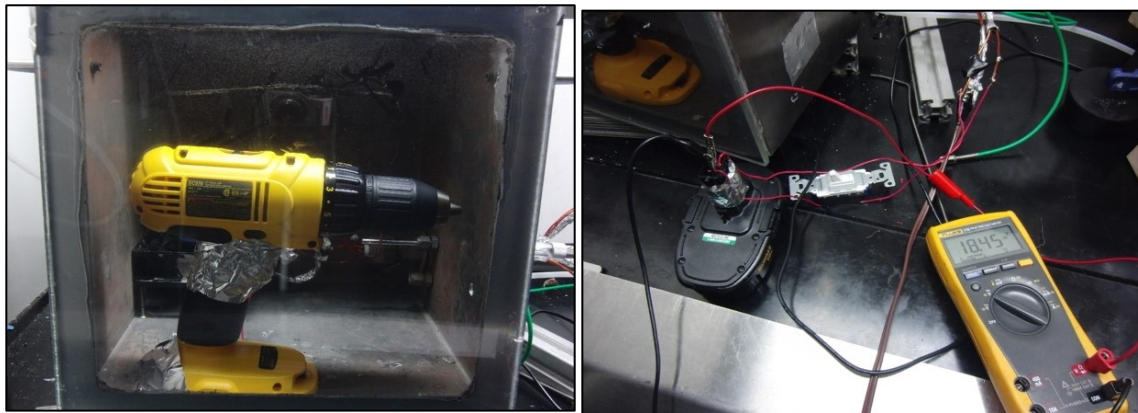

Figure 13.1. Testing configuration for a cordless drill with a brushed motor.

All four refrigerants were tested with the stoichiometric test conditions in Table 13.1. Each refrigerant was tested for at least 120 s. No ignitions were observed.

Table 13.1. Cordless drill results at nearly stoichiometric conditions.

Refrigerant	Mole fraction	Temperature	RH	Ignition
R-32	0.174	22 °C	50%	None
R-452B	0.147	22 °C	47%	None
R-1234yf	0.078	22 °C	50%	None
R-1234ze	0.078	22 °C	47%	None

14 Friction Sparks Results

For friction spark testing, a grinding stone (Forney, \$10.55) with a cordless drill and a ferrocium flint rod (Reliefree, \$7.80) were prepared as pictured in Figure 14.1. The ferrocium flint rod has dimensions of 12.7 mm x 12.7 cm. It is made from iron, magnesium, and ferrocium. The ferrocium is a synthetic pyrophoric alloy that produces friction sparks with high temperature. Temperatures of 3000 °C can be reached when it is oxidized by the process of rapid striking (Wikipedia). To produce friction sparks, the cordless drill was prepared with a grinding stone attachment made from durable high grade 60 grit aluminum oxide. The stone was placed against the flint in the windowed chamber. A switch was installed outside of the chamber to operate the cordless drill.

Refrigerant was introduced at a flow rate of 1 L/min with the chamber fan activated. The gas analyzer monitored the concentration until the desired concentration was achieved. The fan was deactivated and quiescent conditions were obtained. When the premixed mixtures were prepared, the switch was turned on to activate the grinding wheel. Continuous friction sparks were generated as shown in Figure 14.2 for at least 1 min. Four refrigerants were tested with the stoichiometric test conditions in Table 14.1. Continuous friction sparks were visible over a distance of 2-3 cm for at least one minute. No ignitions were observed.

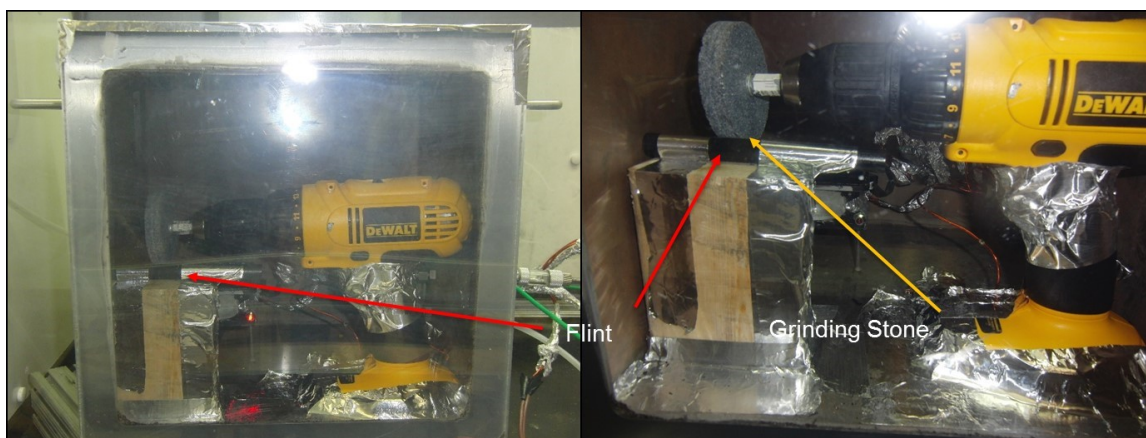

Figure 14.1. Testing configuration for a ferrocium flint rod and a grinding stone.



Figure 14.2. Continuous spark generation.

Table 14.1. Friction sparks results at nearly stoichiometric conditions.

Refrigerant	Mole fraction	Temperature	RH	Ignition
R-32	0.174	22 °C	18%	None
R-452B	0.147	20 °C	15%	None
R-1234yf	0.078	22 °C	18%	None
R-1234ze	0.078	20 °C	14%	None

15 Hair Dryer Results

The risk of ignition from a hair dryer was observed. The hair dryer (Conair Model 124ANP) had dimensions of $0.08 \times 0.11 \times 0.19$ m, as pictured in Figure 15.1. The coil temperature in open air was measured by a bare Type-K thermocouple.

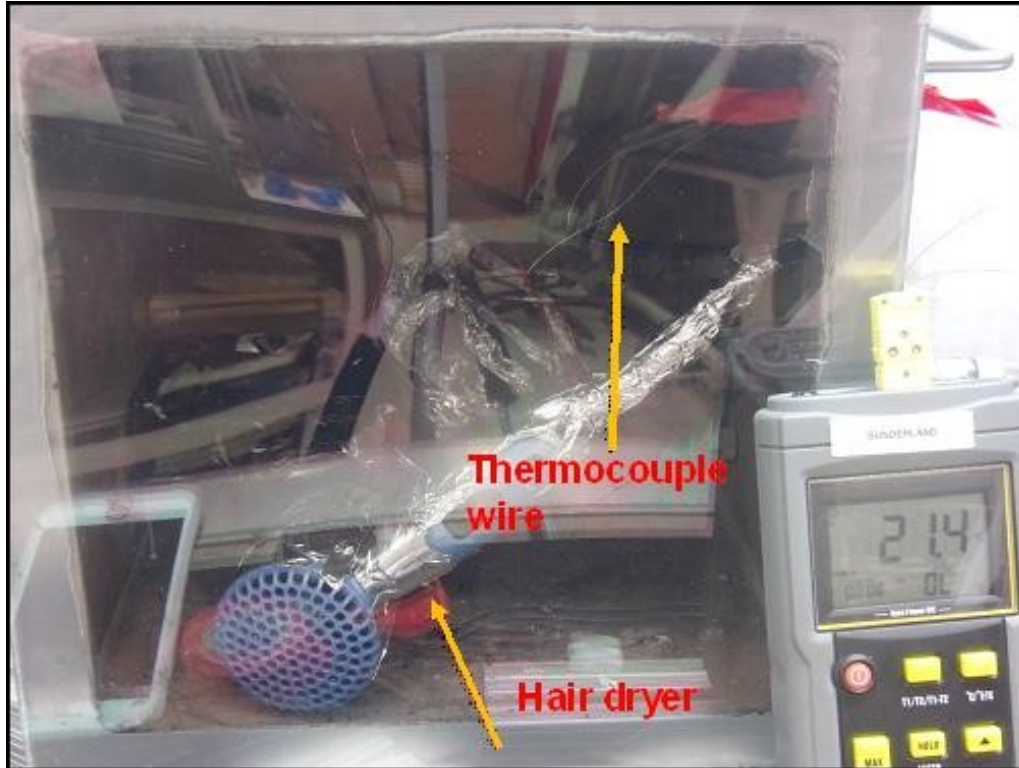

Figure 15.1. Conair 1600 W, 110 VAC hair dryer.

The steady temperature reached around $200\text{ }^{\circ}\text{C}$ as shown in Figure 15.2. The time constant was calculated from

$$\ln\left(\frac{T_{\infty} - T}{T_{\infty} - T_0}\right) = -\frac{t}{\tau}, \quad (5)$$

where T_{∞} was the final temperature of the coil, T_0 was the initial temperature of the coil, and τ was the response time constant. The time constant was found to be 5.12 s.

Hair dryer tests of all four refrigerants were conducted. First, the hair dryer was loaded in the enclosure. Refrigerant was introduced at a flow rate of 1 L/min with the chamber fan activated. The gas analyzer monitored the concentration until the desired concentration was achieved. The fan was deactivated and quiescent conditions were obtained. Finally, the hair dryer was operated for at least 45 s at full power. Four refrigerants were tested with the test conditions in Table 15.1. No ignitions were observed.

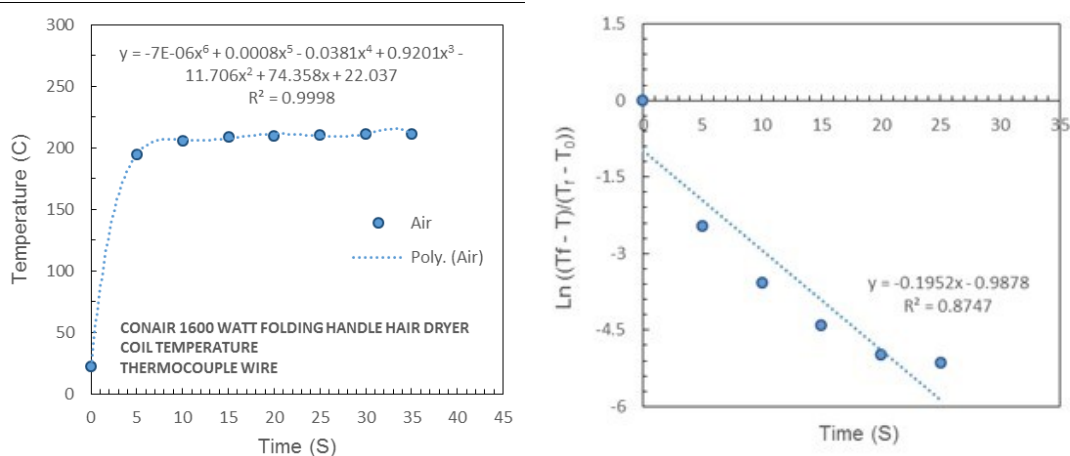

Figure 15.2. Hair dryer temperature measurement.

Table 15.1. Hair dryer results at nearly stoichiometric conditions.

Refrigerant	Mole fraction	Temperature	RH	Ignition
R-32	0.174	N/A	N/A	None
R-452B	0.147	22 °C	33%	None
R-1234yf	0.078	N/A	N/A	None
R-1234ze	0.078	22 °C	34%	None

16 Toaster Results

A study on ignition from a toaster was completed. A 2-slice toaster (Proctor Silex Model 22612) with dimensions of $0.2 \times 0.25 \times 18$ m is shown in Figure 16.1.



Figure 16.1. Toaster installed in the test chamber (Proctor, Silex, \$9.99).

The coil temperatures in open air and refrigerants mixtures were measured by a bare and a shielded thermocouple, respectively. The mixture temperature reached between $215 - 276$ °C, as indicated in Figure 16.2. The temperature of the coil in the air increased rapidly and the maximum temperature measurement was 500 °C. The coil temperature is higher than the autoignition temperature of R-1234yf ($405 - 420$ °C) and R-1234ze (368 °C) reported by Honeywell.

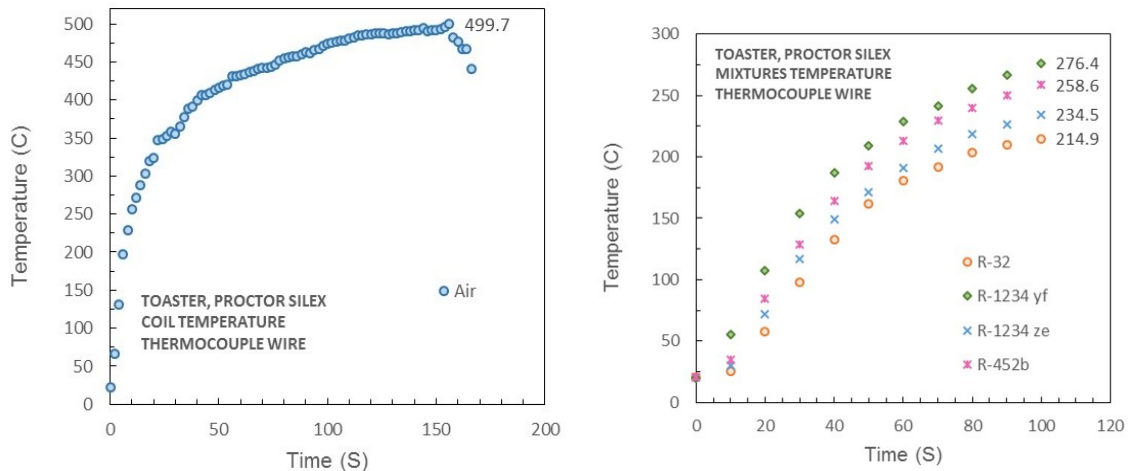

Figure 16.2. Temperatures measured with a thermocouple.

Hot toaster tests of all four refrigerants were conducted. Refrigerant was introduced at a flow rate of 1 L/min with the chamber fan activated. The gas analyzer monitored the concentration until

the desired concentration was achieved. The fan was deactivated and quiescent conditions were obtained. Next, the toaster was operated for at least 100 s.

Test conditions are summarized in Table 16.1. Conditions were stoichiometric. No ignitions were observed.

Table 16.1. Toaster results at nearly stoichiometric conditions.

<u>Refrigerant</u>	<u>Mole fraction</u>	<u>Temperature</u>	<u>RH</u>	<u>Ignition</u>
R-32	0.174	22 °C	24%	None
R-452B	0.147	22 °C	15%	None
R-1234yf	0.078	22 °C	17%	None
R-1234ze	0.078	22 °C	16%	None

17 Hot Plate Insertion Results

A hot plate (Kitchen Selectives Model SB-1) was prepared as shown in Figure 17.1. The temperature of the air around the coils and the heating element temperature were measured with a thermocouple as shown in Figure 17.2. For both, the temperature did not reach steady state within 3 - 5 min. If the hot plate was left to heat inside the sealed test chamber, there was a risk of melting the acrylic window. Furthermore, a hot enclosure increases the likelihood of a dangerous explosion if ignition occurred. This posed a safety risk and an alternate test method was created. As shown in Figure 17.1, the hot plate was connected to a pulley to allow it to lower safely down into the center of the windowed chamber after the hot plate reached steady state temperature and stoichiometric conditions were established inside the chamber.



Figure 17.1. Images of the hot plate insertion tests. The hot plate excitation was 750 W and 120 VAC (Kitchen Selectives, \$11).

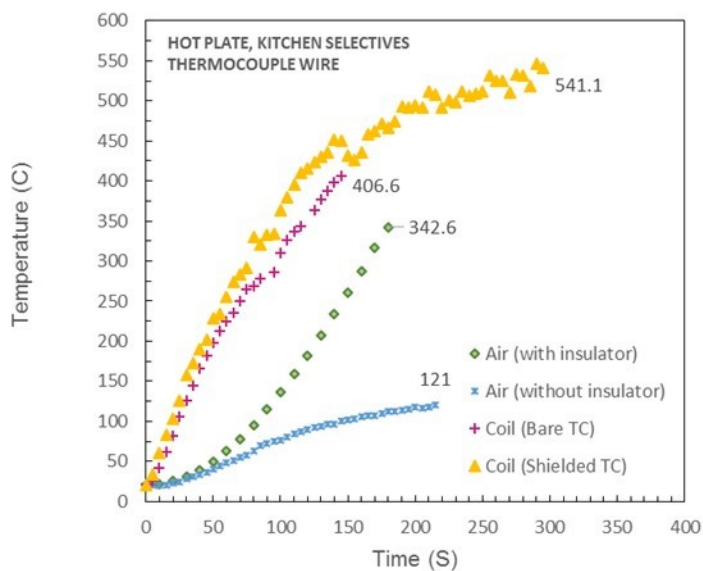

Fig. 17.2. The element temperature was measured with a thermocouple. The maximum measured temperature was 541 °C.



Figure 17.3. Hot plate.

Refrigerant was introduced at a flow rate of 1 L/min with the chamber fan activated. The gas analyzer monitored the concentration until the desired concentration was achieved. The fan was deactivated and quiescent conditions were obtained. The hot plate was inverted and turned on at full power for 10 minutes to reach steady state temperature of its heating element, as shown in Figure 17.3. The heating element faced downward. Then, the aluminum foil cover was cut open by a razor blade to minimize the possibility of the refrigerant leaking from the space. Finally, the hot plate was inserted into the chamber using the pulley. Four refrigerants were tested with the test conditions in Table 17.1. Conditions were stoichiometric. No ignitions were observed.

Table 17.1. Hot plate results at nearly stoichiometric conditions.

Refrigerant	Mole fraction	Temperature	RH	Ignition
R-32	0.174	21 °C	24%	None
R-452B	0.147	21 °C	15%	None
R-1234yf	0.078	22 °C	17%	None
R-1234ze	0.078	22 °C	16%	None

18 Space Heater Insertion Results

The space heater is shown in Figure 18.1. This is a ceramic tower heater (Lasko Model 751320) with a maximum power of 1500 W. The heater (0.58 m tall) was too tall to put inside the 27 L windowed chamber. Accordingly, the space heater tests were conducted with the insertion method, similar to the hot plate experiments.

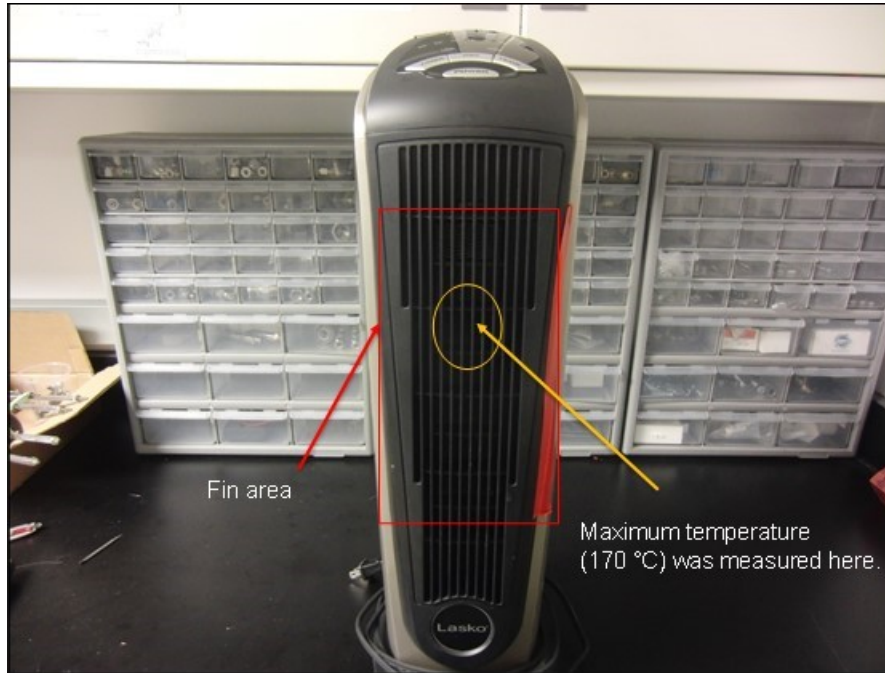

Figure 18.1. Ceramic tower heater.

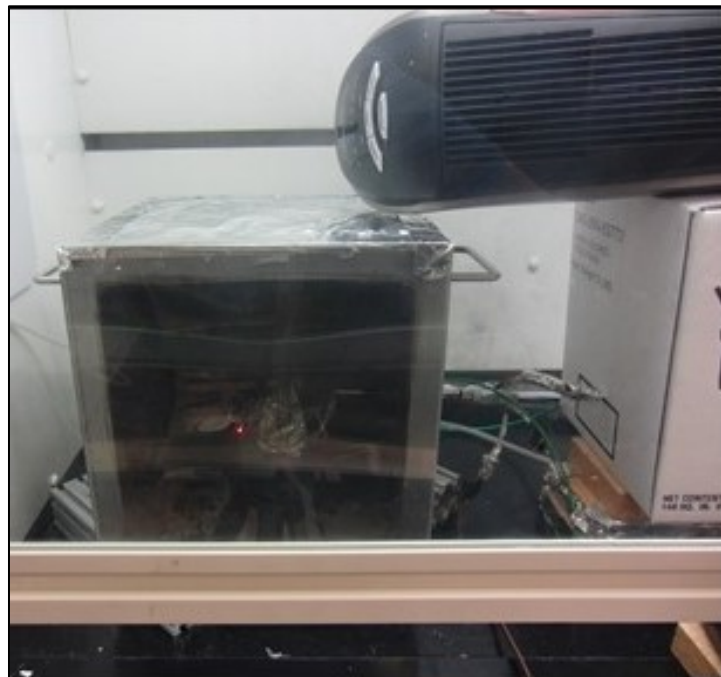

Figure 18.2. Test setup showing the heater just prior to insertion.

Refrigerant was introduced at a flow rate of 1 L/min with the chamber fan activated. The gas analyzer monitored the concentration until the desired concentration was achieved. The fan was deactivated and quiescent conditions were obtained. The heater was prepared separately as shown in Figure 18.2. Then, the heater was turned on for at least 10 minutes to reach the steady state temperature (100 °C) of the fins before it was inserted in the chamber. Fins and heating elements were positioned in the red area shown in Figure 18.1. We did not measure the fin temperature after they were exposed to refrigerant, however the refrigerant was at room temperature and is expected to have little or no effect on this temperature. The temperature of the air around the fins was measured by a shielded thermocouple. Figure 18.3 shows the temperature measurement as function of time. The steady state temperature was reached within 60 s. The maximum temperature of the fins was measured from the center of the heater by a bare thermocouple.

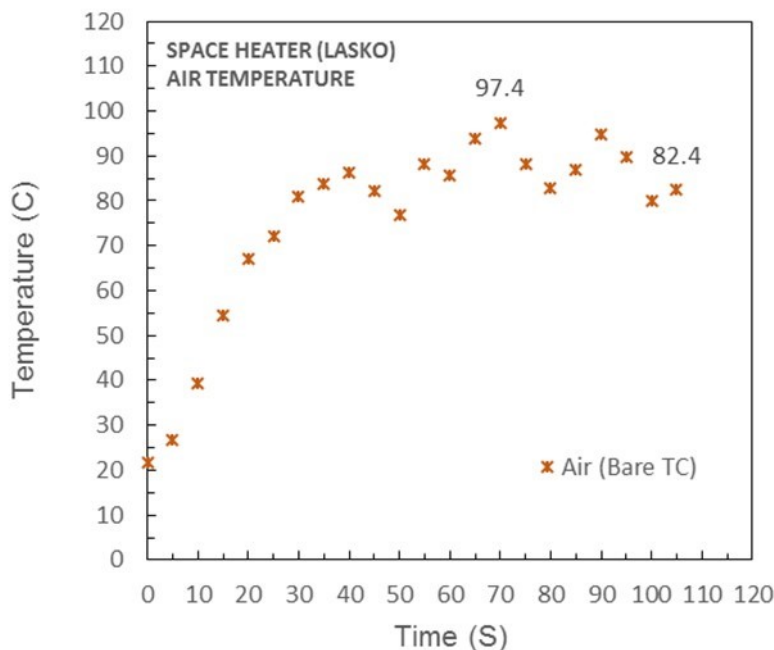

Figure 18.3. Air temperatures measured with a thermocouple.

Next, the aluminum foil cover was cut open by a razor blade to minimize the possibility of the refrigerant leaking from the space. The heater was inserted immediately afterwards. All four refrigerants were tested with the test conditions in Table 18.1. No ignitions were observed.

Table 18.1. Space heater results at nearly stoichiometric conditions.

Refrigerant	Mole fraction	Temperature	RH	Ignition
R-32	0.174	22 °C	18%	None
R-452B	0.147	23 °C	17%	None
R-1234yf	0.078	22 °C	20%	None
R-1234ze	0.078	22 °C	19%	None

19 Conclusions

The overall test matrix and the results summary are shown in Table 19.1. A total of 15 potential ignition sources were used for R-32, R-1234yf, R-1234ze, and R-452b refrigerants, generally mixed stoichiometrically with air.

Table 19.1. Test matrix and result summary.

	R-32	R-452B	R-1234yf	R-1234ze
Hot wire	D	D	D	D
Safety match	D	D	L	D
Lighter flame insertion	D	L	L	L
Leak impinging on candle	L	N	L	L
Cigarette insertion	N	N	N	N
Barbeque lighter	N	N	N	N
Plug and receptacle	N	N	N	N
Light switch	N	N	N	N
Hand mixer	N	N	N	N
Cordless drill	N	N	N	N
Friction sparks	N	N	N	N
Hair dryer	N	N	N	N
Toaster	N	N	N	N
Hot plate insertion	N	N	N	N
Space heater insertion	N	N	N	N

Legend:

D - Deflagration

L - Localized flame

N - No refrigerant combustion

Four of the ignition sources resulted in deflagrations or localized flames in the refrigerant-air mixtures. These were: hot wire, safety match, lighter flame insertion, and leak impinging on candle, in order of decreasing ignition viability.

Among the 15 potential ignition sources, it is remarkable that 11 were unable to ignite any of the mixtures considered here. These were: cigarette insertion, barbeque lighter, plug and receptacle, light switch, hand mixer, cordless drill, friction sparks, hair dryer, toaster, hot plate insertion, and space heater insertion. Excepting the space heater, all these sources have peak temperatures well in excess of the AITs of these refrigerants.

The inability of so many ignition sources to ignite A2L refrigerants is attributed here to the very long quenching distances of these refrigerants when mixed with air. These distances are difficult to measure reliably for A2L refrigerants but are on the order of 8 – 25 mm. Although these 11 ignition sources have high temperatures, these high temperature regions are too close to walls to support combustion.

Another remarkable finding is that these A2L refrigerants can act as either fuels or suppressants. For a strong ignition source like a resistively heat hot wire, they act as fuels. Conversely, smoldering cigarettes were extinguished every time they encountered a stoichiometric mixture of refrigerant and air. The barbeque lighter spark was unable to ignite either the lighter's butane or the surrounding stoichiometric refrigerant mixtures. Candle flames also were extinguished when refrigerants impinged on them, although for a brief time they caused localized burning of refrigerant prior to this suppression.

20 References

- ANSI/ASHRAE Standard 34-2013, *Designation and Safety Classification of Refrigerants* (2013).
- ASTM E582-07, *Standard Test Method for Minimum Ignition Energy and Quenching Distance in Gaseous Mixtures*, ASTM International, West Conshohoken, PA (2007).
- ASTM E681-09, *Standard Test Method for Concentration Limits of Flammability of Chemicals (Vapors and Gases)*, ASTM International, West Conshohoken, PA (2009).
- Boussouf, A., Lecoustre, V.R., Li, H., By, R., Sunderland, P.B., *Ignition of R-32 and R-410A Refrigerant Mixtures with Lubricating Oil*, Purdue Conference on Refrigeration and Air Conditioning (2014).
- Carli, L. (2010 February 11), Space heaters involved in 79 percent of fatal home heating fires, National Fire Protection Association (2010).
- Carvou, E., Jemma, N. Ben, Tian, S., Belhaja, Z., Jusselin, B. Electrical Arc Characterization For Ac Arc Fault Applications, 2009 Proceedings of the 55th IEEE Holm Conference on Electrical Contracts (2009).
- Clodic, D., Jabbour, T., *Method of Test for Burning Velocity Measurement of Flammable Gases and Results*, HVAC&R Res. 17:51-75 (2011).
- Clodic, D., Riachi, Y., *A Method for Determining Practical Flammability Risk When Using Refrigerant Blends*, HVAC&R Res. 15:819-834 (2009).
- Consumer Reports News (2008, March 11), *Don't get burned by these recalled countertop appliances* (2008).
- Ferrocium, <https://en.wikipedia.org/wiki/Ferrocium>. Accessed April 14, 2017.
- Goetzler, W., Bendixen, L., Bartholomew, P., *Risk Assessment of HFC-32 and HFC-32/134a (30/70 wt.%) in Split System Residential Heat Pumps, Final Report*, Arthur D. Little. Report to Air Conditioning and Refrigeration Technology Institute, NTIS DE-98005596; DOE/CE/23810-92. 88p (1998).
- Goetzler, W., Burgos, J., *Study of Input Parameters for Risk Assessment of 2L Flammable Refrigerants in Residential Air Conditioning and Commercial Refrigeration Applications*, ASHRAE Project 1580 Final Report (2012).
- Griffin, W., *Hot plate is blamed for blaze at Belfast Village Soup offices*. Bangor Daily News. (2008).
- Hall, J.R., (2010, November), *Children playing with fire*, NFPA, Quincy, MA, 2010.
- Jabbour, T., Clodic, D., *Ignition Tests of Flammable Refrigerant Leaks in Ventilated and Unventilated Rooms*, 5th IIR Conference on Working Fluids (2002).
- JSRAE, The Japan Society of Refrigerating and Air Conditioning Engineers, *Risk Assessment of Mildly Flammable Refrigerants*, (2013).
- Kataoka, O., Yoshizawa, M., Ohnishi, H., Ishida, S., *Flammability Evaluation of HFC-32 and HFC-32/134a Under Practical Operating Conditions*, Purdue Conference on Refrigeration and Air Conditioning (1996).
- Krasny, J., *Cigarette Ignition of Soft Furnishings-a Literature Review with Commentary*, Technical Study Group Cigarette Safety Act of 1984 (1987).
- Kul, I., Blaszkowski, C., *Flammability Studies of Isomeric Structures of Ethane Derivatives and Percolation Theory*, Int. J. Thermophys. 28:906-917 (2007).
- Kul, I., Gnann, D.L., Beyerlein, A.L., DesMarteau, D.D., *Lower Flammability Limit of Difluoromethane and Percolation Theory*, Int. J. Thermophys. 25:1085-1095 (2004).
- Lewandowski, T.A., *Risk Assessment of Residential Heat Pump Systems Using 2L Flammable Refrigerants*, AHRI Project 8004 Final Report (2012).

- Linteris, G., Manion, J., *Workshop on the Research Needs Concerning the Exothermic Reaction of Halogenated Hydrocarbons*, NIST Technical Note 1871 (2015).
- Mahoney, D. (2012, September 19), *What's so great about brushless motor power tools?*, PM (2012).
- Minor, B.H., Herrmann, D., Gravell, R., *Flammability Characteristics of HFO-123yf*, Process Saf. Progr. 29:150-154 (2010).
- Richard, R.G., *Refrigerant Flammability Testing in Large Volume Vessels*, ARTI Report (1998).
- Richard, R.G., Spatz, M.W., Motta, S.F.Y., *Hot Surface Ignition with 2L Refrigerants*, Honeywell Report (2012).
- Spatz, M., Minor, B. *HFO-1234yf A Low GWP Refrigerant For MAC*, Honeywell / DuPont Joint Collaboration (2008).
- Staff Reports (2012, October 18), *Fire marshal: Safety first when using space heater*, Cumberland Times-News (2012).
- Takahashi, A., Urano, Y., Tokuhashi, K., Kondo, S., *Effect of Vessel Size and Shape on Experimental Flammability Limits of Gases*, J. Haz. Matls. A105:27-37 (2003).
- Takizawa, K., Igarashi, N., Takagi, S., Tokuhashi, K., Kondo, S., *Quenching distance measurement of highly to mildly flammable compounds*, Fire. Saf. J 71:58-68 (2015).
- Takizawa, K., Tokuhashi, K., Kondo, S., *Flammability Assessment of CH₂=CFCF₃: Comparison with Fluoroalkenes and Fluoroalkanes*, J. Haz. Matls. 172:1329-1338 (2009).
- Womeldorf, C., Grosshandler, W., *Flame Extinction Limits in CH₂F₂/Air Mixtures*, Combust Flame 118:25-36 (1999).
- Yee, V., Schwirtz, M.(2015 March 21), *Fire renews concerns over a weekly ritual*. The New York Times (2015).

21 Appendix I. Literature Review

Table 22.1 shows the 155 papers found during our literature review. Also shown is a brief summary of the key knowledge gained by each paper. There are 50 papers on potential ignition sources, 54 papers on ignition tests and ignition energy levels, and 51 papers on the frequency of ignition sources.

Table 22.1 includes many more references than are given in Section 21 above. This is because Section 21 includes only those references that are cited in Sections 1-20.

The key knowledge gained from this literature review is that little experimental work has been done to determine which residential ignition sources are viable for A2L refrigerant leaks.

Table 22.1. Reference summary. The category abbreviations are FIS (frequency of ignition sources); IS (ignition sources); ITEL (ignition tests and energy levels).

No.	Reference	Category	Summary
1	Ahrens, Marty. <i>Automobile Fires in the U.S.: 2006-2010 Estimates</i> . NFPA Fire Analysis Research Division. (2012).	FIS	Statistics on the frequency and cause of automobile fires.
2	Ahrens, Marty. <i>Home Candle Fires</i> . NFPA Fire Analysis and Research Division. (2015).	FIS	Statistics on the frequency and cause of home candle fires.
3	Ahrens, Marty. <i>Home Fires Involving Cooking Equipment</i> . NFPA Research. (2015).	FIS	Statistics on the frequency and cause of fires involving cooking equipment.
4	Ahrens, Marty. <i>Home Structure Fires</i> . NFPA Research. (2015).	FIS	Statistics on the frequency and causes of home fires.
5	Anderson, Glenda. <i>Water heater blamed for massive Rocky Fire in Lake County</i> . The Press Democrat. (2015).	IS	Water heater failure causes fire in California.
6	ANSI/ASHRAE Standard 34-2013, <i>Designation and Safety Classification of Refrigerants</i> (2013).	IS	How to name and classify refrigerants based on toxicity and flammability. Also includes test procedure for refrigerant flammability.
7	ASTM E582-07, <i>Standard Test Method for Minimum Ignition Energy and Quenching Distance in Gaseous Mixtures</i> , ASTM International, West Conshohocken, PA (2007).	IS	Alkane or alkene fuels, STP. Similar to a bomb calorimeter. Tests the Minimum ignition energy and quenching distance of a gaseous mixture.
8	ASTM E681-09, <i>Standard Test Method for Concentration Limits of Flammability of Chemicals (Vapors and Gases)</i> , ASTM International, West Conshohocken, PA (2009).	ITEL	Determining refrigerant flammability by observing size of flame arc in a round flask.

9	Blanc, M.V. Guest, P.G. Elbe, Guenther. Lewis, Bernard. <i>Ignition of Explosive Gas mixtures by Electric Sparks. I. Minimum Ignition Energies and Quenching Distances of Mixtures of Methane, Oxygen and Inert Gases.</i> The Journal of Chemical Physics. (1947).	ITEL	Determining the minimum ignition energy with different spark distances and different pressures, and the effects of inductance. MIE increases as pressure decreases, minimum ignition energy increases as distance between electrodes decreases. There is no effect of inductance.
10	Blewitt, Thomas. Haseman, Randall. Rodgers, Brian. Karnes, Barry. MacLeod, Scott. Wozniak, Robert. <i>White Paper: Revisiting Flammable Refrigerants.</i> (2011). 19 Pages.	ITEL	A paper by UL discussing flammable refrigerants.
11	Bmask Ministry. <i>Consumer fire safety: European Statistics and potential fire safety measures.</i> Ministry of Labour, Social Affairs and Consumer Protection, Netherlands. (2009).	FIS	Statistics on the frequency and cause of fires in Europe.
12	Boussouf, A., Lecoustre, V.R., Li, H., By, R., Sunderland, P.B., <i>Ignition of R-32 and R-410A Refrigerant Mixtures with Lubricating Oil,</i> Purdue Conference on Refrigeration and Air Conditioning (2014).	ITEL	Comparison of auto ignition temperature of refrigerant and refrigerant/lubricating oil mixtures. R-32 AIT was reduced when mixed with oil. Includes CFD analysis.
13	Bowley, Graham. <i>Britain Fire Destroys Beloved Seaside Pier.</i> The New York Times. (2008).	IS	Deep fryer suspected as cause of Seaside Pier fire.
14	Burkhalter, Eddie. <i>Anniston Middle School evacuated as air conditioner sets off fire alarm.</i> The Anniston Star. (2013).	IS	Report of a fire alarm activation in a middle school in Anniston Alabama caused by a faulty air conditioner motor.
15	<i>California Fire Code, 2013 edition.</i> California Building Standards Commission. (2013).	IS	The California Fire Code, Section 606 discusses refrigeration systems.
16	Campbell, Richard. <i>Structure Fires in Warehouse Properties.</i> NFPA. (2016).	FIS	Statistics on the frequency and cause of warehouse fires.
17	Campbell, Richard. <i>U.S. Structure Fires in Office Properties.</i> NFPA Fire Analysis and Research Division. (2013).	FIS	Statistics on the frequency and cause of office fires.
18	Carlsson, T.O. Lamnevik, S.R. <i>Determination of ignition energies and studies of flame propagation in ammonia-air mixtures.</i> Refrigerant Science and Technology. (1996).	ITEL	Determining the ignition energies of ammonia-air mixtures. Stoichiometric mixture put into tube. There does not appear to be a relationship between minimum ignition energy and spark distance. Minimum energy appears to increase with capacitive discharge.
19	Cassidy, Patrick. <i>BRIEF: Firefighters extinguish dishwasher in Pocasset.</i> Cape Cod Times. (2013).	IS	Report of a dishwasher fire in Massachusetts.

20	Chelmsford Weekly News. <i>Essex Fire Service cleans ovens to help save lives.</i> (2014).	IS	Report of fires cause by ovens that had not been cleaned.
21	Chen, Qi. Yan, JiWei. Chen, Guangming. Zhao, Yang. Shi, Yuqi. Zeng, Zhaoyun. Pan, Qinglei. <i>Experimental studies on the flammability of mixtures of dimethyl ether.</i> Journal of Fluorine Chemistry. (2015).	ITEL	Determining the explosion limits and range of dimethyl ether mixtures using ASTM E681.
22	Chicago Daily Herald. <i>Poorly maintained clothes dryer and duct are fire hazards.</i> (2013).	IS	Report on fires started by clothes dryers and how to stop them.
23	Clodic, D., Jabbour, T., <i>Method of Test for Burning Velocity Measurement of Flammable Gases and Results,</i> HVAC&R Res. 17:51-75 (2011).	ITEL	Using a vertical tube test method to determine burning velocity of refrigerants. The gas is ignited at the bottom of the tube and propagates upward. At a constant velocity and pressure, the velocity is refrigerant dependent.
24	Clodic, D., Riachi, Y., <i>A Method for Determining Practical Flammability Risk When Using Refrigerant Blends,</i> HVAC&R Res. 15:819-834 (2009).	ITEL	Using computer models and experiments to determine flammability risk. The experiment uses a 1 m ³ box to determine flammability using gas chromatography. (No flame used)
25	Clodic, Denis. <i>Low GWP refrigerants and flammability classification.</i> (2010).	ITEL	Data collected on the LFL, UFL, MIE Heat of combustion and other properties of R-717, R-152A, R-290, R-32, and R-1234yf.
26	Colbourne, D. Ritter, T.J. <i>Quantitative Risk Assessment of Flammable Refrigerants in Room Air conditioners.</i> International Refrigeration and Air Conditioning Conference. (2002).	ITEL	A quantities risk assessment of flammable refrigerants. Creates different scenarios based on charge size, ignition source location, type of activity, leak type, types of failure of unit components, and flammable volume of source.
27	Consumer Reports. <i>Fire danger found in toasters, deep-fat fryers, and electric grills.</i> Recalls and Safety Alerts. (2008).	IS	Recall notice for toasters, and deep-fat fryers and safety notice for electric grills.
28	Coward, H.F. Jones, G.W. <i>Limits of Flammability of gases and vapors.</i> Bureau of Mines, Bulletin 503. (1952).	ITEL	Determining the flammability limits of various fuels in air, oxygen and other mixtures.
29	Cumberland Times-News. <i>Fire marshal: Safety first when using space heater.</i> (2012).	IS	Report of the State Fire Marshal warning of the fire dangers of portable space heaters.
30	Daily Mirror. <i>10 recalls.</i> (2013).	IS	A recall notice of various products that would overheat or short out and catch fire.
31	Department for Communities and Local Government, Great Britain. <i>Fire Statistics: Great Britain: April 2013 to March 2014.</i>	FIS	Statistics on the cause of fires and sources of ignition of fires in Great Britain from April 2013 to March 2014.

32	Department of Energy Technology, Sweden. <i>Understanding refrigerant flammability</i> . (2015).	ITEL	Data collection. Has LFL vs MIE for gases plot, Heat of combustion vs Burning velocity plot, and GWP plot.
33	Derby Evening Telegraph. <i>Boy started house fire using cigarette lighter</i> . (2010).	IS	Report of a fire set by a young boy playing with a cigarette lighter.
34	Dlugorski, B.Z. Hichens, R.K. Kennedy, E.M. <i>Inert hydrocarbon-based refrigerants</i> . Fire Safety Journal. (2002).	ITEL	Trying to find the minimum inerting concentration of the refrigerants. Test conducted in a tubular flame burner, inerting agent added incrementally to the mixture until the flame goes out.
35	Doyle, Abbey. <i>BRIEF: Outlet causes small fire at Texas Roadhouse</i> . (2011).	IS	Report of a Texas Roadhouse, caused by a short of an electrical outlet.
36	Durham, Robert. Coffin, Jason. Durham, Marcus. <i>Electrical Ignition Demystified</i> . (2014).	ITEL	Report on how electrical ignition can occur, and some ignition data.
37	Eisenberg, Elliot. <i>House Fire Deaths</i> . Housing Economics. (2002).	FIS	Statistics on the frequency and cause of house fire deaths.
38	EMERCOM of Russia. <i>Fire Statistics in the Russian Federation in the year 2008</i> . (2009).	FIS	Statistics on the frequency and cause of fires in Russia.
39	Erie Times-News. <i>BRIEF: Light bulb causes minor fire at Crawford Jail</i> . (2012).	IS	Report of a fire in a jail in Pennsylvania cause by a light bulb.
40	Evarts, Ben. <i>Structure Fires in Eating and Drinking Establishments</i> . NFPA Fire Analysis and Research Division. (2012).	FIS	Statistics on the frequency and cause of fires in eating and drinking establishments.
41	Evening Gazette. <i>Fat fryer causes blaze</i> . (2011).	IS	Report of a deep fat fryer that overheated and ignited.
42	Feja, S. <i>Measurement of electrical properties of refrigerants and refrigerant-oil mixtures</i> . International Journal of Refrigeration. (2012).	ITEL	Determining electrical properties of refrigerant-oil mixtures under pressure. Permittivity decreases with increase in temperature. Specific DC resistivity for pure refrigerants does not change significantly except for R-152A. With oil, the specific resistivity can decrease with temperature.
43	FEMA. <i>Cooking Fires in Residential Buildings (2008-2010)</i> . (2013).	FIS	Statistics on the frequency and cause of cooking fires in residential buildings.
44	FEMA. <i>Fatal Fires in Residential Buildings</i> . Topical Fire Report Series. (2010).	FIS	Statistics on the frequency and cause of fatal residential fires.
45	FEMA. <i>Heating Fires in Residential Buildings (2010-2012)</i> . Topical Fire Report Series. (2014).	FIS	Statistics on the frequency and causes of heating fires in residences.
46	FEMA. <i>Hotel and Motel Fires</i> . Topical Fire Report Series. (2010).	FIS	Statistics on the frequency and cause of hotel and motel fires.

47	FEMA. <i>Large Loss Buildings Fires</i> . Topical Fire Report Series. (2011).	FIS	Statistics on the frequency and cause of large loss building fires.
48	FEMA. <i>Medical Facility Fires</i> . Topical Fire Report Series. (2009).	FIS	Statistics on the frequency and cause of fires in medical facilities.
49	FEMA. <i>Multifamily Residential Building Fires (2011-2013)</i> . Topical Fire Report Series. (2015).	FIS	Statistics on the frequency and causes of fires in multifamily residential buildings.
50	FEMA. <i>Multiple Fatality Fires in Residential Buildings</i> . Topical Fire Report Series. (2009).	FIS	Statistics on the frequency and cause of multiple fatality fires in residential buildings.
51	FEMA. <i>Nonresidential Building Fires (2009-2011)</i> . Topical Fire Report Series. (2013).	FIS	Statistics on the cause of fires in nonresidential buildings in America from 2009-2011.
52	FEMA. <i>One- and Two-Family Residential Building Fires (2008-2010)</i> . (2012).	FIS	Statistics on the frequency and causes of fires in One-and Two Family Residential buildings.
53	FEMA. <i>Portable Heater fires in Residential Buildings (2008-2010)</i> . Topical Fire Report Series. (2012).	FIS	Statistics on the frequency and cause of portable heater fires in residential buildings.
54	FEMA. <i>Residential Building Electrical Fires (2009-2011)</i> . Topical Fire Report Series. (2014).	FIS	Statistics on the frequency and causes of electrical fires in residences.
55	FEMA. <i>Residential Building Fire Trends (2004-2013)</i> . <i>USFA Fire Estimate Summary</i> . (2015).	FIS	Statistics on the frequency and cause of residential building fires.
56	FEMA. <i>Restaurant Building Fires</i> . Topical Fire Report Series. (2011).	FIS	Statistics on the frequency and cause of restaurant building fires.
57	FEMA. <i>University Housing Fires</i> . Topical Fire Report Series. (2010).	FIS	Statistics on the frequency and cause of university housing fires.
58	FEMA. <i>Winter Residential Building Fires</i> . Topical Fire Report Series. (2010).	FIS	Statistics on the frequency and cause of fires in winter residences.
59	Fong, N.K. Wong, K.C. <i>Statistical Data for Fires in Hong Kong and Preliminary views on Building Fire Risk Analysis</i> . Department of Building Services Engineering. (1997).	FIS	Statistics on the frequency and cause of fires in Hong Kong.
60	Gibson, Rachel. <i>House fire sparks appliance warning</i> . The Age. (1995).	IS	Report of various Air conditioner fires, and how appliances with motors need to be regularly checked.
61	Gigel, Andrew. <i>Safety testing of domestic refrigerators using flammable refrigerants</i> . International Journal of Refrigeration. (2002).	ITEL	A domestic refrigerator with flammable refrigerant was tested according to the methods specified in the safety Standard IEC/EN 60335-2-24. This test was mostly for leaks, and a detector was used to determine concentration.

62	Gilbert, James. <i>Microwave fires keep YFD busy</i> . The Sun, Yuma, Arizona. (2009).	IS	Report of a series of microwave fires in Yuma, Arizona.
63	Girodroux, Francis. Kusmierz, Andrew. Dahn, James. <i>Determination of the critical flammability ratio (CFR) of refrigerant blends</i> . Journal of Loss Prevention in the process industries. (2000).	ITEL	Determining the critical flammability ratio of refrigerant blends. There are two different approaches specified in the text. Done by calculation method.
64	Goetzler, W., Bendixen, L., Bartholomew, P., <i>Risk Assessment of HFC-32 and HFC-32/134a (30/70 wt.%) in Split System Residential Heat Pumps, Final Report</i> , Arthur D. Little. Report to Air Conditioning and Refrigeration Technology Institute, NTIS DE-98005596; DOE/CE/23810-92. 88p (1998).	ITEL	Includes flammability tests of HFC-32 using a 1 ft ³ box (ignition tests) and full scale (ignition and concentration mapping), fault tree fire risk analysis for substituting HFC-32 or HFC-32/134a mix for HCFC-22, risk mitigation.
65	Goetzler, W., Burgos, J., <i>Study of Input Parameters for Risk Assessment of 2L Flammable Refrigerants in Residential Air Conditioning and Commercial Refrigeration Applications</i> , ASHRAE Project 1580 Final Report (2012).	ITEL	Risk assessment of 2L refrigerants using CFD, concentration mapping tests, and ignition tests to determine which leak scenarios may be flammable.
66	Goshen News. BRIEF: Investigators: Dunlap Plaza fire caused by 'electrical overload'. (2015).	IS	Report of a fire in shopping plaza in Indiana caused by an electrical overload.
67	Grand Forks Herald. BRIEF: Fan causes small school fire. (2013).	IS	Report of a fire in a middle school in Grand Forks, caused by a floor fan.
68	Gravenhurst Banner. <i>Kitchen fire prompts reminder from fire department</i> . (2015).	IS	Report of a home kitchen fire in Gravenhurst Ontario started by food burning because the stove was left on.
69	Griffin, Walter. <i>Hot plate is blamed for blaze at Belfast Village Soup offices</i> . Bangor Daily News. (2008).	IS	Report of an office kitchen fire that was believed to be started by a hot plate.
70	Hall, John. <i>Estimating fires when a product is the primary fuel but not the first fuel, with an application to upholstered furniture</i> . Fire Technology. (2015).	FIS	Statistics on the frequency and cause of fires with upholstered furniture.
71	Hall, John. <i>High Rise Building Fires</i> . NFPA Fire Analysis Research Division. (2013a).	FIS	Statistics on the frequency and cause of fires in high rise buildings
72	Hall, John. <i>Home Electrical Fires</i> . NFPA Fire Analysis Research Division. (2013b).	FIS	Statistics on the frequency and cause of home electrical fires.
73	Hall, John. <i>Home Fires Involving Heating Equipment</i> . NFPA Fire Analysis and Research Division. (2013c).	FIS	Statistics on fires involving heating equipment in residences in the United States.

74	Hall, John. <i>Home Structure Fires by Equipment Involved in Ignition</i> . NFPA Fire Analysis Research Division. (2013d).	FIS	Statistics on fires in residential in the United States.
75	Hall, John. <i>Home Structure Fires Involving Kitchen Equipment Other Than Cooking Equipment</i> . NFPA Fire Analysis Research Division. (2012).	FIS	Statistics on the frequency and cause of fires involving kitchen equipment other than cooking equipment.
76	Hall, John. <i>Manufactured Home Fires</i> . NFPA Fire Analysis Research Division. (2013e).	FIS	Statistics on the frequency and cause of fires in manufacture homes (e.g. mobile homes).
77	Hall, John. <i>Non-Home Structure Fires By Equipment Involved in Ignition</i> . NFPA Fire Analysis Research Division. (2013f).	FIS	Statistics on fires in non-residential in the United States.
78	Hall, John. <i>The Smoking Material Fire Problem</i> . NFPA Fire Analysis Research Division. (2013g).	FIS	Statistics on the frequency and cause of smoking material fires.
79	Hasofer, A.M. Thomas, I. <i>Analysis of fatalities and injuries in building fire statistics</i> . Fire Safety Journal. (2006).	FIS	Statistics on the frequency and cause of fires with causalities.
80	Heavens, Alan. <i>Safety first: Tips to reduce the risk of house fires</i> . The Philadelphia Inquirer. (2014).	IS	Report of safety tips for various house hazards.
81	Heinonen, E., et. al. <i>Methods Development for Measuring and Classifying Flammability and Combustibility of Refrigerants, Final Report Task 3- Laboratory Test Results</i> . (1994).	ITEL	Determining several parameters of refrigerants. Makes use of Nmeri explosion sphere and ASTM E681.
82	Hills Gazette. <i>Fire figures rise in Hills</i> . (2011).	IS	Report of causes of fires in the Hills area of Perth Australia. Installation deficiency named as the cause of at least 6 fires. At least 14 fires caused by improper use of equipment.
83	Holtappels, K.. Pahl, Robert. <i>Final Test Report: Ignition Behaviour of HFO 1234yf</i> . BAM. (2010). 31 Pages.	ITEL	Report on ignition behavior of HFO-1234yf. Tests done according to DIN 51649 and Enclosed Space Ignition Test: 32.
84	Honeywell Solstice yf Refrigerants: Technical Bulletin. N/A. (2012). 20 Pages.	ITEL	For the battery, matches, and fires, the test method is not specified. The AIT is determined by flow over hot cylindrical bodies. AIT of 405 degrees C of pure HFO-1234yf. One ignition at 700 degrees C for engine compartment testing.

85	Imamura, Tomohiko, Kamiya, Kyoko, Sugawa, Osami. <i>Ignition hazard evaluation of A2L refrigerants in situations of service and maintenance</i> . Journal of Loss Prevention in the Process Industries. (2015).	ITEL	Experimental examination of ignition hazards of A2L refrigerants under plausible accident situations in service and maintenance. Scenario 1 pinhole leak, test potential flammable region if ignition source. Scenario 2, leak from piece of equipment used for service and maintenance, test potential flammable region if ignition source.
86	Jared, Morgan. <i>Service disappointed over cooking fires</i> . The Southland Times (New Zealand). (2006).	IS	Report of a cooking fire in New Zealand.
87	Jones, Nia. <i>Fire statistics Wales, 2014-2015</i> . Statistical Bulletin Bwletin Ystadegol. (2015).	FIS	Statistics on the frequency and cause of fires in Wales.
88	Jorgensen, Lisa. <i>Building manager puts out fire: Quick action with the extinguisher saves WV firefighters a Job</i> . (2005).	IS	Report of a fire in an electrical room of an apartment building, started by a ventilation fan motor.
89	JSRAE, The Japan Society of Refrigerating and Air Conditioning Engineers, <i>Risk Assessment of Mildly Flammable Refrigerants</i> , (2013).	ITEL	Discussion of refrigerant regulation, research on mildly flammable refrigerants, legal issues dealing with refrigerants, hazard evaluation of A2L refrigerants, based on what if analysis and experimental analysis, and other risk assessments.
90	JSRAE, The Japan Society of Refrigerating and Air Conditioning Engineers, <i>Risk Assessment of Mildly Flammable Refrigerants</i> , (2014).	ITEL	Includes studies of effects of humidity on flammability limits, burning velocity, minimum ignition energies, quenching distance. Also includes a risk assessment of mini-split air conditioners, and split air conditioners.
91	Kataoka, O. Yoshizawa, M. Hirakawa, T. <i>Allowable Charge Calculation Method for Flammable Refrigerants</i> . International Refrigeration and Air Conditioning Conference. (2000).	ITEL	Establishing a more scientific method for calculating the allowable refrigerant charge. Leak parameters determined based on refrigerant, leak and room properties. From these, the leak rate is determined, which plays into the vertical concertation equation. The concertation at the floor is assumed to be the LFL in order to determine the allowable charge.
92	Kataoka, O., Yoshizawa, M., Ohnishi, H., Ishida, S., <i>Flammability Evaluation of HFC-32 and HFC-32/134a Under Practical Operating Conditions</i> , Purdue Conference on Refrigeration and Air Conditioning (1996).	ITEL	1st test, 2.7 by 2.7 by 0.6 meter room, 9' by 2' pan of refrigerant, ignited by a DC spark igniter. 2nd test is various ignition tests using glowing Ni-Cr wire, a magnet relay, and a pilot burner.
93	Ketola, Johannes. <i>Finnish Rescue Services' Pocket Statistics 2009-2013</i> . Emergency Services College. (2014).	FIS	Statistics on the frequency and cause of fires in Finland.
94	Killalea, Damien. <i>Reducing Residential Fire Fatalities</i> . United States National	FIS	Paper discussing the residential fire fatality situation in Tasmania.

	Fire Academy. (1999).		
95	Kim, Chul Jin. Choi, Hyo Hyun. Sohn, Chae Hoon. <i>Auto-ignition of lubricating oil working at high pressures in a compressor for an air conditioner.</i> Journal of Hazardous Materials. (2011).	ITEL	Determine AIT of oil at high pressures. Done in an ignition chamber pictured on page 3.
96	Kondo, Shigeo, Takizawa, Kenji, Tokuhashi, Kazuaki. <i>Effects of temperature and humidity on the flammability limits of several 2L refrigerants.</i> Journal of Fluorine Chemistry. (2012).	ITEL	Measurement of flammability limits of refrigerants as a function of temperature and humidity. Uses ASHRAE method for flammability limit testing. Relationship between temperature and flammability was found, but not so much with humidity.
97	Kondo, Shigeo. Takizawa, Kenji. Takahashi, Akifumi. Tokuhashi, Kazuki. Sekiya, Akira. <i>Flammability limits of five selected compounds each mixed with HFC-125.</i> Fire Safety Journal. (2009).	ITEL	Uses ASHRAE method (at 35 degrees C) to determine flammability limits of HFC-125A mixtures. Also makes use of Chatelier's formula to estimate flammability limits.
98	Kondo, Shigeo. Takizawa, Kenji. Tokuhashi, Kazuaki. <i>Flammability limits of binary mixtures of ammonia with HFO-1234yf, HFO-1234ze, HFC-134a, and HFC-125.</i> Journal of Fluorine Chemistry. (2013).	ITEL	Determining the flammability limits of ammonia mixed with various refrigerants using ASHRAE 34, except with dry air at 35 degrees C.
99	<i>Korean Fire Data.</i> Korean Fire Protection Association. (2010).	FIS	Statistics on the frequency and cause of fires in Korea.
100	Kul, I., Blaszkowski, C., <i>Flammability Studies of Isomeric Structures of Ethane Derivatives and Percolation Theory,</i> Int. J. Thermophysics. 28:906-917 (2007).	ITEL	LFL tests of R-143 and R-143a (using ASTM E681). An investigation on the effects of vessel size with LFL was also conducted.
101	Kul, I., Gnann, D.L., Beyerlein, A.L., DesMarteau, D.D., <i>Lower Flammability Limit of Difluoromethane and Percolation Theory,</i> Int. J. Thermophysics. 25:1085-1095 (2004).	ITEL	An investigation on the effects of vessel size on the LFL of R-32 was conducted.
102	Landry, Alysia. Farmington Daily Times. <i>The cost of keeping warm: Space heaters a leading cause in home fires.</i> (2007).	IS	Report of safety tips for space heaters and other heating equipment.
103	Law, Tina. <i>Caution urged over dryer use after fire.</i> The Press. (2016).	IS	Report of several fires in 2015 caused by clothes in a clothes dryer.
104	Lewandowski, T.A., <i>Risk Assessment of Residential Heat Pump Systems Using 2L Flammable Refrigerants,</i> AHRI Project 8004 Final Report (2012).	ITEL	Characterizing risk of 2L refrigerants, using CFD, experimental measurements and fault tree analysis.
105	Lewellyn, Daryn. <i>Arc-Flash Safety: Implementing NFPA 70E.</i> Professional Safety. (2013).	IS	Analyzing NFPA 70E with respect to Arc flash.

106	Li, Guohui. Lu, Song. Mei, Peng. Zhang, Heping. Lo, Siuming. <i>Influences of Time, Location, and Cause Factors on the Probability of Fire Loss in China: A Correspondence Analysis.</i> Fire Technology. (2014).	FIS	Statistics on the frequency and cause of fires in China by fire loss.
107	Li, Tingxun. <i>Indoor leakage test for safety of R-290 split type room air conditioner.</i> International Journal of Refrigeration. (2014).	ITEL	Using inflammable gas detectors to determine a concentration map of refrigerant leaked out of a room air conditioner unit.
108	Linteris, G., Manion, J., <i>Workshop on the Research Needs Concerning the Exothermic Reaction of Halogenated Hydrocarbons</i> , NIST Technical Note 1871 (2015).	ITEL	Discussion of the exothermic reaction of halogenated hydrocarbons, touching on fire suppression industry in ground-based and aircraft applications and HVAC industries.
109	Liu, Xueling. Zhang, Qi. <i>Influence of initial pressure and temperature on flammability limits of hydrogen-air.</i> Int. J. Hydrogen Energy. (2014).	ITEL	Determining the influence of initial pressure and temperature on the flammability limits of hydrogen and air mixtures. Tests conducted in a partially submerged vessel, 5 L cylinder.
110	Manchester Evening News. <i>Ward is evacuated after toaster fire.</i> (2011).	IS	Report of a hospital ward evacuation after a toaster fire in Manchester.
111	Meeks, Emily. <i>BRIEF: Heat lamp cause fire that killed six puppies.</i> High Point Enterprise. (2015).	IS	Report of a fire in North Carolina caused by a heat lamp.
112	Minor, B.H., Herrmann, D., Gravell, R., <i>Flammability Characteristics of HFO-123yf</i> , Process Saf. Progr. 29:150-154 (2010).	ITEL	Study of flammability properties and impact on the safe use of HFO-123yf in a vehicle. Includes CFD model of HFO-123yf leak into a passenger compartment of a vehicle, burning velocity test analysis, minimum ignition energy test analysis, and ignition source viability tests.
113	Mohanraj, M. Jayaraj, S. Muraleedharan, C. Chandrasekar, P. <i>Experimental investigation of R290/R600a mixture as an alternative to R134a in a domestic refrigerator.</i> International Journal of Thermal Sciences. (2009).	ITEL	Determine if R-290/R-600 could be used as a drop in replacement for R-134A.
114	Monforte, Roberto, Caretto, Luca, <i>Safety Issues in the application of a Flammable Refrigerant Gas in MAC Systems: The OEM Perspective.</i> SAE International. (2009).	ITEL	Determine if HFO-1234yf is suitable for mobile air conditioners (MACs). Includes LFL, UFL, and MIE information for HFO-1234yf, R-32, ammonia and other fuels. Determines quenching distance, MIE, burning velocity, LFL, UFL, heat of combustion and AIT for HFO-1234yf. Ignition sources used in testing: Fuses, motors, control resistors, power switches, control switches, lamps, battery, heaters, pyrotechnics, rotating devices, pulleys, and lighters.

115	National Directorate for Fire Emergency Management, Ireland. <i>Causes of Fires Attended by Fire Brigades in 2014</i> . (2015).	FIS	Statistics on the causes of fires attended by fire brigades in Ireland.
116	New South Wales Community Safety Division. <i>Fire Fatalities report, Study of Fatal fires in NSW from 2004 to 2008</i> . (2009).	FIS	Statistics on the frequency and cause of fatal fires in New South Wales.
117	New Zealand Fire Service. <i>Emergency Incident Statistics 2012-2013</i> . (2015).	FIS	Statistics on the frequency and cause of fire incidents in New Zealand.
118	Nottingham Evening Post. <i>Time to do those checks on safety</i> . (2009).	IS	Safety report for landlords, check various appliances for safety (Boiler, ovens, washing machines, vacuum cleaners, fixed wiring).
119	Novak, Bill. <i>Fan fire damages home on south side</i> . The Capital Times. (2010).	IS	Report of a fire caused by a fan that melted then fell over.
120	Ono, Ryo, Nifuku, Masaharu, Fujiwara, Shuzo, Horiguchi, Sadashige, Oda, Tetsuji. <i>Minimum ignition energy of hydrogen-air mixture: Effects of humidity and spark duration</i> . Journal of Electrostatics. (2007).	ITEL	Measurement of effects of humidity and spark duration on minimum ignition energy. Test conducted in a 1 L stainless steel chamber.
121	Petitfrere, Claire, Proust, Christophe. <i>Analysis of Ignition Risk on Mechanical Equipment in ATEX</i> . PCIC Europe Conference Record Location. (2007).	ITEL	Series of experiments for objects under the ATEX directive, including ignition by friction tests, ignition by heated surface tests, volumetric ignition, spark ignition, modeling, and ignition by impact.
122	Pocono Record. <i>Fire breaks out in trash compactor at East Stroudsburg Kmart</i> . (2013).	IS	Report of a fire in a Kmart trash compactor, possibly caused by a disposed cigarette.
123	Presutto, Milena. Scialdoni, Raffaele. Cutaia, Laura. Mebane, William. Esposito, Rita. Faberi, Stefano. <i>Preparatory Studies for Eco-design Requirements of EuPs: Lot 13: Domestic Refrigerators and Freezers Final Report, Tasks 6-7</i> . (2005). 295 Pages.	ITEL	Study by BAM on the design of domestic refrigerators and freezers.
124	Previch, Chad. <i>Fridge linked to deadly fire; Regular cleanings are safety issue, experts say</i> . The Oklahoman. (2006).	IS	Report of a fire in Oklahoma City that was started by a refrigerator motor, killing seven.
125	Proust, Christophe. <i>Flammability assessment HFO-R1234yf</i> . INERIS. (2008).	ITEL	A presentation by INERIS on HFO-R1234yf, includes quenching distance vs. minimum ignition energy, and ignition sources that need further study.
126	Pyle, Robin. <i>Officials point to space heater in deadly blaze</i> . Lubbock Avalanche-Journal. (2008).	IS	Report of a fatal fire in Texas was caused by a space heater.

127	Richard, R.G., <i>Refrigerant Flammability Testing in Large Volume Vessels</i> , ARTI Report (1998).	ITEL	Investigation of the true flame propagation for difficult to ignite refrigerants by studying the effect of combustion vessel volume on the appearance of the flame.
128	Rosenberg, Tommy. <i>Statistics for fire prevention in Sweden</i> . Fire Safety Journal. (1999).	FIS	Statistics on the frequency and cause of fires in Sweden.
129	Sekizawa, Al. <i>International Comparison Analysis on Fire Risk among the United States, the United Kingdom, and Japan</i> . Fire Safety Science. (1994).	FIS	Statistics on the frequency and cause of fires in Japan, USA and UK.
130	<i>Statistical Bulletin: Crime and Justice Series</i> . The Scottish Government. (2014).	FIS	Statistics on the frequency and cause of fires in Scotland.
131	Takahashi, A., Urano, Y., Tokuhashi, K., Kondo, S., <i>Effect of Vessel Size and Shape on Experimental Flammability Limits of Gases</i> , J. Haz. Matls. A105:27-37 (2003).	ITEL	Tests of the effect of vessel size and shape on flammability limits, using methane and propane.
132	Takizawa, K., Tokuhashi, K., Kondo, S., <i>Flammability Assessment of CH₂=CF₃: Comparison with Fluoroalkenes and Fluoroalkanes</i> , J. Haz. Matls. 172:1329-1338 (2009).	ITEL	Tests of flammability limits and burning velocity of 1234yf.
133	The Hutchinson News. <i>BRIEF: Hutchinson Fire chief believes a discarded cigarette caused a small trash can fire at local motel</i> . (2015).	IS	Report of a fire in a motel in Hutchinson Kansas, believed to be caused by a discarded cigarette.
134	The Jamestown Sun. <i>BRIEF: Refrigerator causes fire in Jamestown</i> . (2008).	IS	Report of a fire in Jamestown, North Dakota caused by a refrigerator.
135	The Portales, News-Tribune. <i>BRIEF: Official: Air conditioner started fire</i> . (2009).	IS	Report of a fire in New Mexico caused by the air conditioner's motor.
136	The Press. <i>Child playing with matches destroys house</i> . (2015).	IS	Report of a child playing with matches which cause the house to burn down.
137	The Sedalia Democrat. <i>BRIEF: Police: House fire caused by juvenile playing with matches</i> . (2010).	IS	Report of a house fire caused by juvenile playing with matches.
138	The Sedalia Democrat. <i>BRIEF: Sedalia Fire Department: House catches fire after stove left on</i> . (2010).	IS	Report of a fire in Sedalia Missouri caused by a stove being left on.
139	The Sentinel. <i>Fatal fire sparked by cigarette lighter</i> . (2015).	IS	Report of a fatal fire in Utttoxeter England caused by a cigarette lighter.
140	Thompson, Elaine. <i>Fire warning: Safety checks are essential to avoid disaster</i> . Telegram & Gazette. (2009).	IS	Fire safety report on electrical safety checks after a fire started by a refrigerator malfunction.

141	Tschirschwitz, Rico. Schroder, Volkamer. Brandes, Elisabeth. Krause, Ulrich. <i>Determination of explosion limits - Criterion for ignition under non-atmospheric conditions</i> . Journal of Loss Prevention in the Process Industries. (2015).	ITEL	Determining explosion limits and limiting oxidizer concentration at non-atmospheric conditions. Uses a steel 11 dm cubed cylinder autoclave.
142	Twomey, John. The Express. <i>Sark blaze sparked by vacuum cleaner</i> . (2008).	IS	Report of a fire in a museum/boat was started by a fire that was overheated, did not have a thermal cut-out.
143	US Official News. <i>Virginia: Accidental Great Falls Fire</i> . (2014).	IS	Fire safety report on electrical safety checks after a fire started by an electrical malfunction.
144	Vicars, Richard. Small, James. Munson, Terry. Parrish, Christopher. <i>Low Voltage: The Incompetent Ignition Source Dispelling the Myth</i> . (2010).	ITEL	A report on how low voltage electrical energy can still cause ignition.
145	Wijayasinghe, Mahendra. <i>Fire Losses in Canada, Year 2007 and Selected Years</i> . Office of the Fire Commissioner. (2011).	FIS	Statistics on the frequency and cause of fires in Canada.
146	Wilson, Marie. <i>Refrigerator Motor starts Naperville townhouse fire</i> . Chicago Daily Herald. (2015).	IS	Report of a fire in Naperville Illinois that killed a cat, caused by a refrigerator motor.
147	Windsor Star. <i>Light bulb blamed for \$40 million boathouse fire</i> . (2011).	IS	Report of a boathouse fire in Port Lambton Ontario, suspected to be caused by a light bulb.
148	Wirral Globe. <i>Toaster catches fire in Wirral House</i> . (2013).	IS	Report of a fire in Pensby caused by a toaster.
149	Xin, Jing. Huang, Chong Fu. <i>Fire Risk Assessment of Residential Buildings Based on Fire Statistics from China</i> . Fire Technology. (2013).	FIS	Statistics on the frequency and cause of fires in residential buildings in China.
150	Yang, Zhao. Wu, Xi. Peng, Jijun. <i>Theoretical and Experimental investigation on the flame-retarding characteristic of R245fa</i> . Experimental Thermal and Fluid Science. (2013).	ITEL	Determining the LFL of flammable refrigerants mixed with R-245a. Uses the Chinese GB/T12474-90 test, which is a long glass tube with an ignitor at the bottom.
151	Yee, Vivian. Schwirtz, Michael. <i>Fire renews Concerns Over a Weekly Ritual</i> . The New York Times. (2015).	IS	Report of a fire caused by a malfunctioning hot plate cause multi-fatality fire.
152	Zhang, Wang. Yang, Zhao. Li, Jin. Ren, Chang-xing. Lu, Dong. Wang, Jie. Zhang, Xin. Wu, Wei. <i>Research on the flammability hazards of an air conditioner using refrigerant R-290</i> . International Journal of Refrigeration. (2013).	ITEL	Testing flammability limits of a leak from an air conditioner unit into a 'typical master bedroom' in China. Also includes an ignition test.

153	Zhang, Wang, Zhao, Yang, Li, Jin, Ren, Chang-xing, Lv, Dong. <i>Study of the explosion characteristics of air conditioner using flammable refrigerants</i> . Journal of Fire Sciences. (2015).	ITEL	Tested in a 20 L 'ball' very similar to ASHRAE.
154	Zhao, Yang, Bin, Liu, Haibo, Zhao. <i>Experimental study of the inert effect of R134a and R227ea on explosion limits of the flammable refrigerants</i> . Experimental Thermal and Fluid Science. (2004).	ITEL	Using GB/T12474-90 to determine the explosion limits of the refrigerant mixtures.
155	Zhao, Yang, Yie, Li, ZhengGuo, Zhang. <i>Investigation of Flammability for Alternative Mixtures in Air Conditioner and Refrigeration Systems</i> . Journal of Fire Sciences. (2001).	ITEL	Determining under what conditions is a leak in an air conditioner considered dangerous. This is done by deterring at what temperatures the refrigerants have what concentration.

22 Appendix II. Past Test Summary

Table 21.1 summarizes the past ignition tests for refrigerants.

The key knowledge gained from this literature review is that little experimental work has been done to determine which residential ignition sources are viable for A2L refrigerant leaks.

Table 21.1. Past test summary table.

Refrigerant	Oil	Ignition Source	Surface Type	Surface Temperature or Energy	Ignition?	Enclosure Dimensions	RH and temperature	Reference
R-32	None	Hot Surface	Flat Plate	764 C	Yes	3 cm tall draft shield around hot surface	Ambient	Boussouf et al. (2014)
R-410A	None	Hot Surface	Flat Plate	790 C	Yes	3 cm tall draft shield around hot surface	Ambient	Boussouf et al. (2014)
POE Oil	Oil	Hot Surface	Flat Plate	645 C	Yes	3 cm tall draft shield around hot surface	Ambient	Boussouf et al. (2014)
R-32	Oil	Hot Surface	Flat Plate	649 C	Yes	3 cm tall draft shield around hot surface	Ambient	Boussouf et al. (2014)
R-32	No Oil	High Voltage Arc	Box	15000 V Secondary	Yes	1 ft ³ box	Ambient	Goetzler et al. (1998)
R-32	None	Low Voltage Arc	Box	17000 V Secondary Peak	Yes	1 ft ³ box	Ambient	Goetzler et al. (1998)
R-32	None	Low Voltage Arc	Box	24 V Input	No	1 ft ³ box	Ambient	Goetzler et al. (1998)
R-32	None	Electrical Spark Across Wires	Box	240 V, 96 A, 42 PF	Yes	1 ft ³ box	Ambient	Goetzler et al. (1998)
R-32	None	Electrical Spark Across Wires	Box	120 V, 72 A, 50 PF	Yes	1 ft ³ box	Ambient	Goetzler et al. (1998)
R-32	None	Electrical Spark Across Wires	Box	120 V, 16 A, 75 PF	No	1 ft ³ box	Ambient	Goetzler et al. (1998)
R-32	None	Supplemental heating Equipment	Box	Normal Operating Temperature	No	1 ft ³ box	Ambient	Goetzler et al. (1998)
R-32	None	Supplemental heating Equipment	Box	Red Hot	No	1 ft ³ box	Ambient	Goetzler et al. (1998)
R-32	None	Supplemental heating Equipment	Box	White Hot	Yes	1 ft ³ box	Ambient	Goetzler et al. (1998)
R-32	None	Hot Wire Ignitor	Box	120 V Rated	No	1 ft ³ box	Ambient	Goetzler et al. (1998)
R-32	None	Light Bulb	Box	Broken Bulb	Yes	1 ft ³ box	Ambient	Goetzler et al. (1998)
R-32	None	Light Bulb	Box	Halogen, Intact Bulb	No	1 ft ³ box	Ambient	Goetzler et al. (1998)
R-32	None	Match	Box	Ohio Blue Tip Wooden Match	Yes	1 ft ³ box	Ambient	Goetzler et al. (1998)
R-32	None	Switches	Box	120 V, 96 A, 50% PF	No	1 ft ³ box	Ambient	Goetzler et al. (1998)
R-32	None	Switches	Box	120 V, 72 A, 50% PF	No	1 ft ³ box	Ambient	Goetzler et al. (1998)
R-32	None	Switches	Box	120 V, 15.2 A	No	1 ft ³ box	Ambient	Goetzler et al. (1998)

R-32	None	Open Flame	Box	Propane	Yes	1 ft ³ box	Ambient	Goetzler et al. (1998)
R-32	None	Open Flame	Box	Natural Gas	Yes	1 ft ³ box	Ambient	Goetzler et al. (1998)
R-32	None	Motor	Box	Open, 240 V, 5.4 A, ¾ hp	No	1 ft ³ box	Ambient	Goetzler et al. (1998)
R-32	None	Motor	Box	Totally Enclosed 240 V, 1.4 A, ¼ hp	No	1 ft ³ box	Ambient	Goetzler et al. (1998)
R-32	None	Motor	Box	Electric Drill, 120 V, 2.2 A	No	1 ft ³ box	Ambient	Goetzler et al. (1998)
R-32	None	Contactora	Box	240 V, 96 A, 42 PF, Open	Yes	1 ft ³ box	Ambient	Goetzler et al. (1998)
R-32	None	Contactora	Box	240 V, 35 A, 77 PF, Open	Yes	1 ft ³ box	Ambient	Goetzler et al. (1998)
R-32	None	Contactora	Box	240 V, 96 A, 42 PF, Top Removed	No	1 ft ³ box	Ambient	Goetzler et al. (1998)
R-32	None	Contactora	Box	240 V, 20.5 A, 47 PF, Open	No	1 ft ³ box	Ambient	Goetzler et al. (1998)
R-32/134a (60/40)	None	High Voltage Arc	Box	15000 V Secondary	Yes	1 ft ³ box	Ambient	Goetzler et al. (1998)
R-32/134a (60/40)	None	Low Voltage Arc	Box	17000 V Secondary Peak	Yes	1 ft ³ box	Ambient	Goetzler et al. (1998)
R-32/134a (60/40)	None	Low Voltage Arc	Box	24 V Input	No	1 ft ³ box	Ambient	Goetzler et al. (1998)
R-32/134a (60/40)	None	Electrical Spark Across Wires	Box	240 V, 96 A, 42 PF	No	1 ft ³ box	Ambient	Goetzler et al. (1998)
R-32/134a (60/40)	None	Electrical Spark Across Wires	Box	120 V, 72 A, 50 PF	No	1 ft ³ box	Ambient	Goetzler et al. (1998)
R-32/134a (60/40)	None	Supplemental heating Equipment	Box	Normal Operating Temperature	No	1 ft ³ box	Ambient	Goetzler et al. (1998)
R-32/134a (60/40)	None	Supplemental heating Equipment	Box	Red Hot	No	1 ft ³ box	Ambient	Goetzler et al. (1998)
R-32/134a (60/40)	None	Supplemental heating Equipment	Box	White Hot	Yes	1 ft ³ box	Ambient	Goetzler et al. (1998)
R-32/134a (60/40)	None	Hot Wire Ignitor	Box	120 V Rated	No	1 ft ³ box	Ambient	Goetzler et al. (1998)
R-32/134a (60/40)	None	Light Bulb	Box	Broken Bulb	Yes	1 ft ³ box	Ambient	Goetzler et al. (1998)
R-32/134a (60/40)	None	Match	Box	Ohio Blue Tip Wooden Match	Yes	1 ft ³ box	Ambient	Goetzler et al. (1998)
R-32/134a (60/40)	None	Open Flame	Box	Propane	Yes	1 ft ³ box	Ambient	Goetzler et al. (1998)
R-32/134a (60/40)	None	Open Flame	Box	Natural Gas	Yes	1 ft ³ box	Ambient	Goetzler et al. (1998)
R-32/134a (60/40)	None	Motor	Box	Open, 240 V, 5.4 A, ¾ hp	No	1 ft ³ box	Ambient	Goetzler et al. (1998)
R-32/134a (60/40)	None	Motor	Box	Totally Enclosed 240 V, 1.4 A, ¼ hp	No	1 ft ³ box	Ambient	Goetzler et al. (1998)
R-32/134a (60/40)	None	Motor	Box	Electric Drill, 120 V, 2.2 A	No	1 ft ³ box	Ambient	Goetzler et al. (1998)

R-32/134a (60/40)	None	Contactator	Box	240 V, 96 A, 42 PF, Open	Yes	1 ft ³ box	Ambient	Goetzler et al. (1998)
R-32/134a (60/40)	None	Contactator	Box	240 V, 35 A, 77 PF, Open	No	1 ft ³ box	Ambient	Goetzler et al. (1998)
HFC-152A	None	Burning Cigarette	Glass Pipe	Burning Cigarette	No	8.5 liter glass pipe	50% RH air, 23°C	Minor et al. (2009)
HFC-152A	None	Glowing Hot Wire	Glass Pipe	Glowing Hot Wire	Yes	8.5 liter glass pipe	50% RH air, 23°C	Minor et al. (2009)
HFC-152A	None	Butane Lighter Flame	Glass Pipe	Butane Lighter Flame	Yes	8.5 liter glass pipe	50% RH air, 23°C	Minor et al. (2009)
HFC-152A	None	Fused Ni-chrome Wire	Glass Pipe	Fused Ni-chrome Wire	Yes	8.5 liter glass pipe	50% RH air, 23°C	Minor et al. (2009)
HFC-32	None	Burning Cigarette	Glass Pipe	Burning Cigarette	No	8.5 liter glass pipe	50% RH air, 23°C	Minor et al. (2009)
HFC-32	None	Glowing Hot Wire	Glass Pipe	Glowing Hot Wire	No	8.5 liter glass pipe	50% RH air, 23°C	Minor et al. (2009)
HFC-32	None	Butane Lighter Flame	Glass Pipe	Butane Lighter Flame	Yes	8.5 liter glass pipe	50% RH air, 23°C	Minor et al. (2009)
HFC-32	None	Fused Ni-chrome Wire	Glass Pipe	Fused Ni-chrome Wire	Yes	8.5 liter glass pipe	50% RH air, 23°C	Minor et al. (2009)
Ammonia	None	Burning Cigarette	Glass Pipe	Burning Cigarette	No	8.5 liter glass pipe	50% RH air, 23°C	Minor et al. (2009)
Ammonia	None	Glowing Hot Wire	Glass Pipe	Glowing Hot Wire	No	8.5 liter glass pipe	50% RH air, 23°C	Minor et al. (2009)
Ammonia	None	Butane Lighter Flame	Glass Pipe	Butane Lighter Flame	Weak Ignition	8.5 liter glass pipe	50% RH air, 23°C	Minor et al. (2009)
Ammonia	None	Fused Ni-chrome Wire	Glass Pipe	Fused Ni-chrome Wire	Yes	8.5 liter glass pipe	50% RH air, 23°C	Minor et al. (2009)
HFO-1234yf	None	Burning Cigarette	Glass Pipe	Burning Cigarette	No	8.5 liter glass pipe	50% RH air, 23°C	Minor et al. (2009)
HFO-1234yf	None	Glowing Hot Wire	Glass Pipe	Glowing Hot Wire	No	8.5 liter glass pipe	50% RH air, 23°C	Minor et al. (2009)
HFO-1234yf	None	Butane Lighter Flame	Glass Pipe	Butane Lighter Flame	Weak Ignition	8.5 liter glass pipe	50% RH air, 23°C	Minor et al. (2009)
HFO-1234yf	None	Fused Ni-chrome Wire	Glass Pipe	Fused Ni-chrome Wire	Yes	8.5 liter glass pipe	50% RH air, 23°C	Minor et al. (2009)
HFO-1234yf	None	Copper electrodes	Glass sphere	12 V Car Battery	No	12 L glass sphere	50% RH, 20°C	Minor et al. (2009)
HFO-1234yf	None	Copper electrodes	Glass sphere	12 V Car Battery	No	12 L glass sphere	50% RH, 60°C	Minor et al. (2009)
HFO-1234yf	None	Copper electrodes	Glass sphere	12 V Car Battery	No	12 L glass sphere	50% RH, 80°C	Minor et al. (2009)
Ammonia	None	Copper electrodes	Glass sphere	12 V Car Battery	Yes	12 L glass sphere	50% RH, 20°C	Minor et al. (2009)
Ammonia	None	Copper electrodes	Glass sphere	12 V Car Battery	Yes	12 L glass sphere	50% RH, 60°C	Minor et al. (2009)
HFO-1234yf	42 cc	Hot Surface	Cyl.	500°C	No	1m3 with vent box bottom	Ambient, 92°C	Monforte et al. (2009)
HFO-1234yf	42 cc	Hot Surface	Cyl.	750°C	No	1m3 with vent box bottom	Ambient, 92°C	Monforte et al. (2009)
HFO-1234yf	42 cc	Hot Surface	Cyl.	800°C	Yes	1m3 with vent box bottom	Ambient, 92°C	Monforte et al. (2009)
HFO-1234yf	12 cc	Hot Surface	Cyl.	800°C	Yes	1m3 with vent box bottom	Ambient, 92°C	Monforte et al. (2009)
HFO-1234yf	18 cc	Hot Surface	Cyl.	800°C	Yes	1m3 with vent box bottom	Ambient, 92°C	Monforte et al. (2009)
HFO-1234yf	18 cc	Hot Surface	Cyl.	500°C	Yes	1m3 with vent box bottom	Ambient, 104°C	Monforte et al. (2009)

HFO-1234yf	18 cc	Hot Surface	Cyl.	700°C	No	1m3 with vent box bottom	Ambient, 96°C	Monforte et al. (2009)
HFO-1234yf	18 cc	Hot Surface	Cyl.	750°C	Yes	1m3 with vent box bottom	Ambient, 72°C	Monforte et al. (2009)
HFO-1234yf	18 cc	Hot Surface	Cyl.	750°C	No	1m3 with vent box bottom with thermal shield	Ambient, 80°C	Monforte et al. (2009)
HFO-1234yf	18 cc	Hot Surface	Cyl.	800°C	Yes	1m3 with vent box bottom with thermal shield	Ambient, 90°C	Monforte et al. (2009)